

Technical Data Index

<u>Description</u>	<u>Page</u>
<u>Product Information</u>	2-3
<u>Specifications</u>	4
<u>Temperature Limits</u>	4
Lubrication	
<u>Grease</u>	5
<u>Dry Film</u>	6
<u>Ptfe Liner</u>	7
<u>Bearing Misalignment</u>	8
<u>Suggested Housing Bores</u>	9-11
<u>Bearing Installation</u>	12-13
<u>Groove Type Chart</u>	14

Technical Data

Product Information

Rod Ends

Aurora Bearing Company rod ends are manufactured utilizing two construction styles. They are of the two or three-piece type. Both types feature the advantages of metal-to-metal contact between bearing components (PTFE to metal interface may also be incorporated when specified).

The standard two-piece style consists of a body and precision ground oil impregnated sintered steel ball. This type of construction allows the rod end body to carry a greater radial static load and the oil-impregnated ball is self-lubricating under normal operating conditions. This unit also offers greater misalignment capabilities. A variety of material and plating options for the component parts in this series are available. Any cold-formable steel in stainless and alloy steel categories can be specified for the body, and all hardenable alloys such as 52100 and 440 C stainless steel may be employed as options for the ball component.

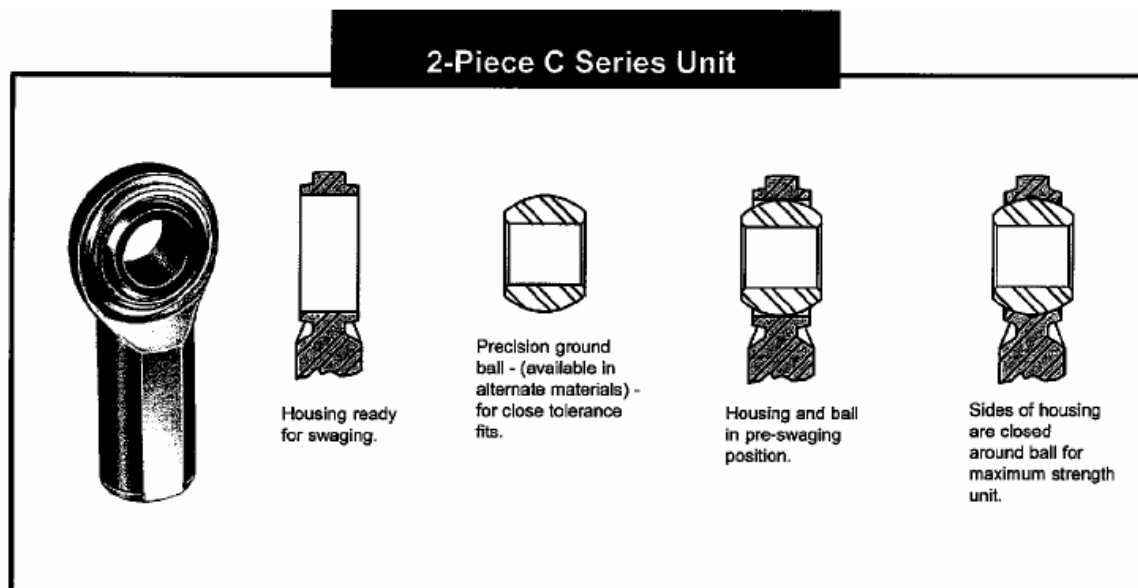

The three-piece style consists of a body, ball, and race. This type of unit, offering fully swaged bearing construction, features the advantages of maximum spherical conformity between the ball and race. It also offers flexibility in that many different types of materials can be interchanged in each component part, providing combinations that can be tailored to meet just about any application requirement. Consult our engineering department for materials to fit your special application. Materials used in the standard catalog items are outlined on the appropriate detail page of the catalog.

3-Piece A & M Series Unit

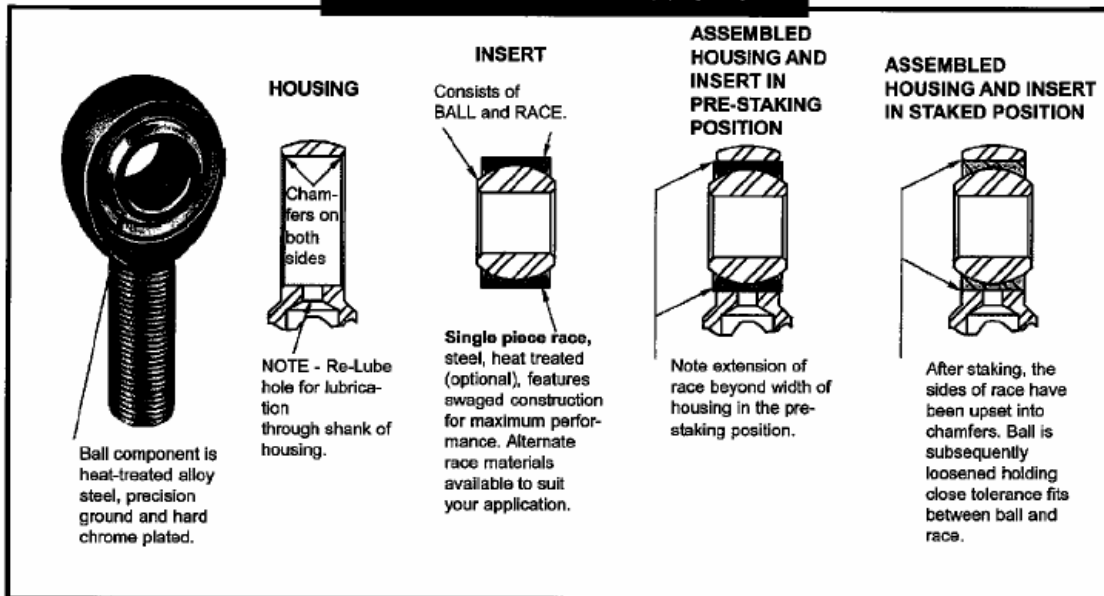

Spherical Bearings

These bearings incorporate the single piece race type construction, also providing excellent ball to race conformity. They can be re-lubricated through an annular groove in the outer race with two interconnecting holes positioned at 180°. Various metals may also be substituted in these types of units to meet special requirements. Recommended housing bores are given on pages 54-56 of the Commercial Catalog # 503 and also in the technical data area of the web site.

Specifications

Bearings manufactured at Aurora Bearing Company are in accordance with the highest standards attained within the bearing industry. Processing and materials are certifiable to military and Federal specifications or, when required, processed to customer standards. Following are some of the specifications that we process to:

Heat treat	AMS 2759
Chrome plate	AMS-QQ-C-320
Zinc plate	ASTM B 633
Cadmium plate	AMS-QQ-P-416
Magnetic Particle Inspect	ASTM E 1444
Passivate	AMS-QQ-P-35
Part marking/packaging	MIL-STD-130

*The above specifications are subject to change at any time due to revision, cancellation, or replacement.

Temperature Limits

The following is a listing of what ultimate temperatures Aurora Bearing Company standard catalog series are capable of operating in. With the exception of the Teflon lined series, all bearings must be well lubricated with a suitable grease to meet the stated temperature.

<u>250°F</u>	<u>325°F</u>	<u>400°F</u>	<u>500°F</u>	<u>600°F</u>
MM-T	HXAM-T	CM KM-M	AM	SM-E
MW-T	HAB-T	CW KW-M	AW	SW-E
AM-T	PRM-T	VCM COM-M	AM-M	COM-E
AW-T	PRXM-T	VCW COM	AW-M	
CM-ET	PNB-T/-TG	MM HCOM	COM-KH	
CW-ET	PWB-T/-TG	MW MIB	HCOM-KH	
MM-MT	ASM(K)-T	KM LCOM	AIB	
MW-MT	ASW(K)-T	KW XM	SIB	
AIB-T	ANC-T/-TG	SM ASM(K)	XAM	
MIB-T	AWC-T/-TG	SW ASW(K)	RAM	
SIB-T	AJB	CM-S GMM	RXAM	
		CW-S GMW		
		CM-M		
		CW-M		
		MM-M		
		MW-M		

Lubrication

Grease

Grease is an oil that has synthetic filler, thickener, metallic soap, or a combination of the three added to prevent oil migration from the lubrication site. The operative properties of grease depend mostly on the base oil.

Metal on metal spherical bearings are supplied with lubrication grooves and holes to provide the ability for lubrication. Metal on metal rod ends can be furnished with grease fittings along with the lubrication grooves and holes to allow for lubrication. These bearings could gall without frequent lubrication and a reversing load to keep the grease from being pushed out. In applications with one direction loading, the grease will tend to be squeezed out of the bearing area. These types of applications should be evaluated for the use of dry film or Teflon. Following are the most common greases used by Aurora Bearing Company.

Type	Specification	Composition	Temperature Range
Mobilux® Ep2	N/A	Lithium Hydroxystearate based grease	-66°F to 266°F
Aeroshell 7®	MIL-PRF-23827	Synthetic base oil w/ non-melting inorganic thickener	-100°F to 300°F
Aeroshell 17®	MIL-G-21164	Synthetic base oil w/ non-melting inorganic thickener	-100°F to 300°F
Aeroshell 33®	MIL-PRF-23827; Boeing Specification BMS 3-33	Synthetic base oil w/ lithium complex thickener	-100°F to 250°F

Mobilux® is a registered trademark of the ExxonMobil Company.

Aeroshell® is a registered trademark of Shell Corporation

Note: The above-mentioned lubricants are current at the time of publication and are subject to change at any time without notice.

Dry Film Lubricants

Dry film lubricants offer high quality lubricating solids blended with specially formulated inorganic or organic resin binder systems, resulting in films, which can be applied to most surfaces as self-lubricating, dry coatings. These coatings contain a variety of solid lubricants, including molybdenum disulfide, graphite, and PTFE. They are utilized where extreme pressure, temperature, or environments such as radiation, vacuum, dust, or dirt, and corrosive operating conditions, limit the use of conventional lubricants.

Aurora Bearing Company can provide most of our standard catalog rod ends and spherical bearings with dry film lubricants. Consult our sales representatives for details. Following are the most common dry film lubricants used by Aurora Bearing Company.

Type	Specification	Lubricant	Binder	Temperature Range
Lube-lok® 4396	MIL-L-8937	MoS ₂ , Graphite	High Molecular- Weight Phenolic	-300°F to 450°F
Everlube® 620	MIL-L-8937	MoS ₂	High Molecular- Weight Phenolic	-100°F to 300°F
Everlube® 811	MIL-L-81329; MIL-PRF-81329	MoS ₂ , Graphite	Silicate	-365°F to 750°F

Lube-lok® & Everlube® are registered trademarks of E/M Corporation.

Note: The above-mentioned lubricants are current at the time of publication and are subject to change at any time without notice.

Teflon Liners

PTFE (bonded coated PTFE liner) lined races are available in all three-piece bearing units and all spherical bearings. The steel race has a self-lubricating liner; a PTFE impregnated woven fabric, chemically bonded to the inner diameter of the race. Aurora Bearing Company's ptf liners are maintenance free and offer improved frictional characteristics. Following are the liners that Aurora Bearing Company offers.

Liner Designation	AT 1400	AT 2100	AT 2300	AT 3200
Construction	PTFE/Dacron Laminate	PTFE/Fiberglass Weave	PTFE/Dacron Weave	PTFE/Nomex Laminate
Thickness (in.)	.012-.014	.010-.012	.013-.015	.014-.016
Temperature (°F)	-65° to 250°	-65° to 250°	-65° to 250°	-65° to 350°
Static Limit Load	80,000 PSI	60,000 PSI	75,000 PSI	80,000 PSI
Stiffness	Medium to High	Medium	Low	Medium to High
Typical Performance	40,000 PSI @ ±25° & 10-20 cpm .0045 wear max. @ 25,000 cycles	25,000 PSI @ ±25° & 10-20 cpm .0060 wear max. @ 5,000 cycles	Contact Aurora Bearing Company Engineering Department	40,000 PSI @ ±25° & 10-20 cpm .0045 wear max. @ 25,000 cycles
Dynamic Capabilities	Light to medium, unidirectional or alternating loads. Low speed intermittent to continuous misalignment, intermittent to continuous oscillation.	Light unidirectional loads. Low speed, intermittent to continuous misalignment, intermittent to continuous oscillation	Light to medium, alternating or reversing loads. Medium to high speed, intermittent to continuous misalignment, intermittent to continuous oscillation.	Light to heavy, unidirectional or alternating loads. Low speed, intermittent to continuous misalignment, intermittent to continuous oscillation.
Comments	Good multi-purpose system	Excellent stick-slip properties, usually recommended for high splash or underwater applications	Excellent stick-slip properties, good vibratory conditions	Highest performance characteristics for all applications, Qualified to SAE-AS81820

Bearing Misalignment

A rod end or spherical bearing's ability to misalign is measured by the degree of angle the ball can accommodate without interference. The angle of misalignment in a rod end is limited by the ball width and head diameter as shown in figure 1. This arrangement is called a clevis mount, and is the type represented in the standard rod end detail pages of the catalog. If added misalignment is necessary, this can be accomplished by utilizing spacers between the clevis mounting and ball face, or by using special rod ends designed to meet specific requirements.

Misalignment angle in a spherical bearing is limited by the ball and race width with respect to the ball diameter, illustrated in figure 3. This is the mounting type for spherical bearings represented in the standard detail pages of the catalog. Mounting arrangements for spherical bearings such as shown in figures 2 through 4 are also used with rod ends. The misalignment angle is then calculated by selecting the proper formula.

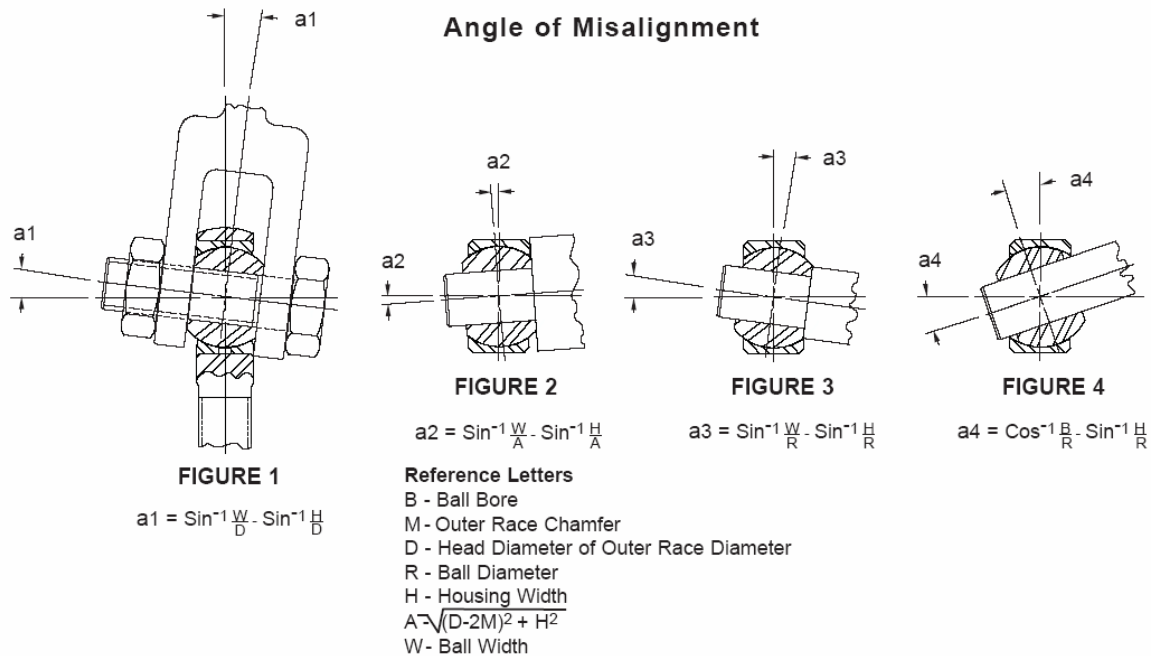

Suggested Housing Bores

Tables are representative of Metal to Metal parts, please consult our engineering department regarding PTFE lined parts.

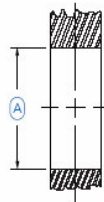

Suggested Housing Bores Spherical Plain Bearings

Bearing Series GEZ..ES GEZ..ES..2RS	DIMENSIONS IN INCHES									
	A Suggested Housing Bore For Press Fit of Spherical Plain Bearings									
	Bearing Outside Diameter		ISO H7		ISO M7		ISO N7		Extra Heavy Press Fit	
	Max.	Min.	Max.	Min.	Max.	Min.	Max.	Min.	Max.	Min.
008	.8750	.8745	.8758	.8750	.8750	.8742	.8747	.8739	.8743	.8735
010	1.0625	1.0625	1.0633	1.0625	1.0625	1.0617	1.0622	1.0614	1.0610	1.0620
012	1.2500	1.2495	1.2510	1.2500	1.2500	1.2490	1.2497	1.2487	1.2485	1.2475
014	1.4375	1.4370	1.4385	1.4375	1.4375	1.4365	1.4372	1.4362	1.4360	1.4350
016	1.6250	1.6245	1.6260	1.6250	1.6250	1.6240	1.6247	1.6237	1.6235	1.6225
020	2.0000	1.9995	2.0012	2.0000	2.0000	1.9988	1.9996	1.9985	1.9987	1.9975
022	2.1875	2.1870	2.1887	2.1875	2.1875	2.1863	2.1871	2.1860	2.1862	2.1850
024	2.4375	2.4370	2.4387	2.4375	2.4375	2.4363	2.4371	2.4360	2.4362	2.4350
028	2.8125	2.8120	2.8137	2.8125	2.8125	2.8113	2.8210	2.8110	2.8112	2.8100
032	3.1875	3.1869	3.1889	3.1875	3.1875	3.1861	3.1871	3.1857	3.1859	3.1845
036	3.5625	3.5619	3.5639	3.5625	3.5625	3.5611	3.5621	3.5607	3.5604	3.5590
040	3.9375	3.9369	3.9389	3.9375	3.9375	3.9361	3.9357	3.9371	3.9354	3.9340
044	4.3750	4.3744	4.3764	4.3750	4.3750	4.3736	4.3746	4.3732	4.3729	4.3715
048	4.7500	4.7493	4.7516	4.7500	4.7500	4.7484	4.7495	4.7418	4.7476	4.7460
052	5.1250	5.1243	5.1266	5.1250	5.1250	5.1234	5.1245	5.1230	5.1226	5.1210
056	5.5000	5.4993	5.5016	5.5000	5.5000	5.4984	5.4995	5.4980	5.4976	5.4960
060	5.8750	5.8743	5.8766	5.8750	5.8750	5.8734	5.8745	5.8730	5.8726	5.8710
064	6.2500	6.2490	6.2516	6.2500	6.2500	6.2484	6.2495	6.2480	6.2476	6.2460
068	6.6250	6.6240	6.6266	6.6250	6.6250	6.6234	6.6245	6.6230	6.6226	6.6210
072	7.0000	6.9990	7.0016	7.0000	7.0000	6.9984	6.9995	6.9980	6.9976	6.9960
076	7.3750	7.3740	7.3768	7.3750	7.3750	7.3732	7.3744	7.3726	7.3728	7.3710
080	7.7500	7.7490	7.7518	7.7500	7.7500	7.7482	7.7494	7.7476	7.7478	7.7460
096	8.7500	8.7490	8.7518	8.7500	8.7500	8.7482	8.7494	8.7476	8.7478	8.7460

Bearing Series GE..ES GE..ES..2RS	DIMENSIONS IN MILLIMETERS									
	A Suggested Housing Bore For Press Fit of Spherical Plain Bearings									
	Bearing Outside Diameter		ISO H7		ISO M7		ISO N7		Extra Heavy Press Fit	
	Max.	Min.	Max.	Min.	Max.	Min.	Max.	Min.	Max.	Min.
12	22.000	21.991	22.021	22.000	22.000	21.979	21.993	21.972	21.982	21.962
15	26.000	25.991	26.021	26.000	26.000	25.979	25.993	25.972	25.962	25.937
17	30.000	29.991	30.021	30.000	30.000	29.979	29.993	29.972	29.962	29.937
20	35.000	34.989	35.025	35.000	35.000	34.975	34.992	34.967	34.962	34.937
25	42.000	41.989	42.025	42.000	42.000	41.975	41.992	41.967	41.967	41.937
30	47.000	46.989	42.025	47.000	47.000	46.975	46.992	46.967	46.967	46.937
35	55.000	54.987	55.030	55.000	55.000	54.970	54.991	54.961	54.967	54.937
40	62.000	61.987	62.030	62.000	62.000	61.970	61.991	61.961	61.967	61.937
45	68.000	67.987	68.030	68.000	68.000	67.970	67.991	67.961	67.967	67.937
50	75.000	74.987	75.030	75.000	75.000	74.970	74.991	74.961	74.967	74.937
60	90.000	89.985	90.035	90.000	90.000	89.965	89.990	89.955	89.967	89.911
70	105.000	104.985	105.035	105.000	105.000	104.965	104.990	104.955	104.967	104.911
80	120.000	119.985	120.035	120.000	120.000	119.965	119.990	119.955	119.967	119.911
90	130.000	129.982	130.040	130.000	130.000	129.960	129.988	129.948	129.939	129.898
100	150.000	149.982	150.040	150.000	150.000	149.960	149.988	149.948	149.939	149.898
110	160.000	159.975	160.040	160.000	160.000	159.960	159.988	159.948	159.939	159.898
120	180.000	179.975	180.040	180.000	180.000	179.960	179.988	179.948	179.939	179.898
140	210.000	209.970	210.046	210.000	210.000	209.954	209.949	209.940	209.995	209.898
160	230.000	229.970	230.046	230.000	230.000	229.954	229.949	229.940	229.995	229.898

ISO H7 - Fit recommended for light loads where axial displacement is required after installation.

ISO M7 - Press fit where bearing is subjected to combination, reversing, or shock loads.

ISO N7 - Recommended fit when using a light alloy housing (i.e. aluminum).

EXTRA HEAVY PRESS FIT - Recommended fit for applications with extreme shock loads that can also tolerate elevated breakaway torques. A sufficiently rigid housing is assumed.

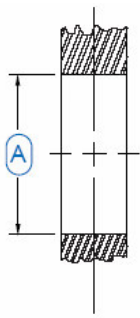

Suggested Housing Bores COM, HCOM, MIB, AIB & SIB Spherical Bearings

COM & HCOM Series

Bearing Series COM HCOM	DIMENSIONS IN INCHES				
	A Suggested Housing Bore For Press Fit of Spherical Bearings				
	Bearing Outside Diameter +.0000 -.0007	Steel Housing		Aluminum Housing	
Max.		Min.	Max.	Min.	
3	.5625	.5619	.5614	.5618	.5612
4	.6562	.6556	.6551	.6555	.6549
5	.7500	.7494	.7489	.7493	.7487
6	.8125	.8119	.8114	.8118	.8112
7	.9062	.9056	.9051	.9055	.9049
8	1.0000	.9994	.9989	.9993	.9987
9	1.0937	1.0931	1.0925	1.0930	1.0923
10	1.1875	1.1869	1.1863	1.1868	1.1861
12	1.4375	1.4369	1.4363	1.4368	1.4361
14	1.5625	1.5619	1.5613	1.5618	1.5611
16	1.7500	1.7494	1.7486	1.7493	1.7485
16	2.0000	1.9994	1.9986	1.9993	1.9985
19	2.3750	2.3744	2.3736	2.3743	2.3735
20	2.3750	2.3744	2.3736	2.3743	2.3735
24	2.7500	2.7494	2.7486	2.7493	2.7485
28	3.1250	3.1244	3.1236	3.1243	3.1235
32	3.5000	3.4994	3.4986	3.4993	3.4985

Bearing Series COM HCOM	DIMENSIONS IN MILLIMETERS				
	A Suggested Housing Bore For Press Fit of Spherical Bearings				
	Bearing Outside Diameter +.000 -.018	Steel Housing		Aluminum Housing	
Max.		Min.	Max.	Min.	
3	14.288	14.272	14.260	14.270	14.255
4	16.667	16.652	16.640	16.650	16.634
5	19.050	19.035	19.022	19.032	19.017
6	20.638	20.622	20.610	20.620	20.604
7	23.018	23.002	22.990	23.000	22.985
8	25.400	25.385	25.372	25.382	25.367
9	27.780	27.765	27.750	27.762	27.744
10	30.162	30.147	30.132	30.145	30.127
12	36.512	36.497	36.482	36.495	36.477
14	39.688	39.672	39.657	39.670	39.652
16	44.450	44.435	44.414	44.432	44.412
16	50.800	50.785	50.764	50.782	50.762
19	60.325	60.310	60.289	60.307	60.287
20	60.325	60.310	60.289	60.307	60.287
24	69.850	69.835	69.814	69.832	69.812
28	79.375	79.360	79.339	79.357	79.337
32	88.900	88.885	88.864	88.882	88.862

Dimensions given in the above tables are for bearings fabricated of standard race materials. Should other materials be used, consult our engineering department for modification of these dimensions.

RADIAL STATIC LOAD CAPACITY

These loads are maximum static based on maximum permanent set in the bearing race of 0.2% of the ball diameter. If a greater permanent set can be allowed or if alternate race materials are used consult our engineering department for change factors.

AXIAL STATIC LOAD CAPACITY

These loads are approximately 20% of the radial loads listed when the load bearing surfaces are properly supported.

ALTERNATE RACE AND BALL MATERIALS

Materials other than those listed can be incorporated in bearings manufactured by Aurora Bearing Company. Stainless steels to improve corrosion resistance, heat treated alloy steels to increase wear life are frequently used in special applications.

PTFE lined races are also available in this series to provide service requiring no relubrication and improved frictional characteristics. Tables are representative of Metal to Metal parts, please consult our engineering department regarding PTFE lined parts.

MIB, AIB & SIB Series

Bearing Series MIB AIB SIB	DIMENSIONS IN INCHES				
	A Suggested Housing Bore For Press Fit of Spherical Bearings				
	Bearing Outside Diameter +.0000 -.0007	Steel Housing		Aluminum Housing	
Max.		Min.	Max.	Min.	
3	.5312	.5306	.5301	.5305	.5299
4	.6094	.6088	.6083	.6087	.6081
5	.7500	.7494	.7489	.7493	.7487
6	.8437	.8431	.8426	.8430	.8424
7	1.0000	.9994	.9989	.9993	.9987
8	1.0937	1.0931	1.0925	1.0930	1.0923
10	1.3125	1.3119	1.3113	1.3118	1.3111
12	1.5000	1.4994	1.4988	1.4993	1.4986
14	1.6250	1.6244	1.6236	1.6243	1.6235
16	2.1250	2.1244	2.1236	2.1243	2.1235

Bearing Series MIB AIB SIB	DIMENSIONS IN MILLIMETERS				
	A Suggested Housing Bore For Press Fit of Spherical Bearings				
	Bearing Outside Diameter +.000 -.018	Steel Housing		Aluminum Housing	
Max.		Min.	Max.	Min.	
3	13.492	13.477	13.465	13.475	13.460
4	15.479	15.464	15.451	15.461	15.446
5	19.050	19.035	19.022	19.032	19.017
6	21.430	21.415	21.402	21.412	21.397
7	25.400	25.385	25.372	25.382	25.367
8	27.780	27.765	27.750	27.762	27.744
10	33.338	33.322	33.307	33.320	33.302
12	38.100	38.085	38.070	38.082	38.064
14	41.275	41.259	41.239	41.257	41.237
16	53.975	53.960	53.939	53.957	53.937



Suggested Housing Bores LCOM & COM-M Spherical Bearings

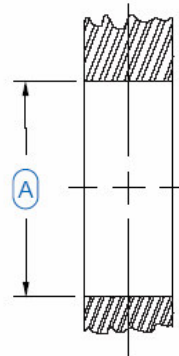

LCOM Series

COM-M Series

Bearing Series LCOM	DIMENSIONS IN INCHES				
	(A) Suggested Housing Bore For Press Fit of Spherical Bearings				
	Bearing Outside Diameter +.0000 -.0007	Steel Housing		Aluminum Housing	
Max.		Min.	Max.	Min.	
3	.6250	.6244	.6239	.6243	.6237
4	.7500	.7494	.7489	.7493	.7487
5	.8750	.8744	.8739	.8743	.8737
6	1.0000	.9994	.9989	.9993	.9987
7	1.1875	1.1869	1.1863	1.1868	1.1861
8	1.3125	1.3119	1.3113	1.3118	1.3111
10	1.5625	1.5619	1.5613	1.5618	1.5611
12	2.2500	2.2494	2.2486	2.2493	2.2485
12-1	1.8750	1.8744	1.8736	1.8743	1.8735
16	2.3750	2.3744	2.3736	2.3743	2.3735
19	2.6250	2.6244	2.6236	2.6243	2.6235
24	3.2500	3.2494	3.2486	3.2493	3.2485
30	4.0000	3.9994	3.9986	3.9993	3.9985

Bearing Series COM-M	DIMENSIONS IN MILLIMETERS				
	(A) Suggested Housing Bore For Press Fit of Metric Spherical Bearings				
	Bearing Outside Diameter + .000 - .018	Steel Housing		Aluminum Housing	
Max.		Min.	Max.	Min.	
3	12	11.985	11.972	11.982	11.967
5	16	15.985	15.972	15.982	15.967
6	18	17.985	17.972	17.982	17.967
8	22	21.985	21.972	21.982	21.967
10	26	25.985	25.972	25.982	25.967
12	30	29.985	29.969	29.982	29.964
14	34	33.985	33.969	33.982	33.964
16	38	37.985	37.969	37.982	37.964
18	42	41.985	41.969	41.982	41.964
20	46	45.985	45.964	45.982	45.962
22	50	49.985	49.964	49.982	49.962
25	56	55.985	55.964	55.982	55.962
30	66	65.985	65.964	65.982	65.962

Bearing Series LCOM	DIMENSIONS IN MILLIMETERS				
	(A) Suggested Housing Bore For Press Fit of Spherical Bearings				
	Bearing Outside Diameter + .000 - .018	Steel Housing		Aluminum Housing	
Max.		Min.	Max.	Min.	
3	15.875	15.860	15.847	15.857	15.842
4	19.050	19.035	19.022	19.032	19.017
5	22.225	22.210	22.197	22.207	22.192
6	25.400	25.385	25.372	25.382	25.367
7	30.163	30.148	30.132	30.145	30.127
8	33.338	33.323	33.307	33.320	33.302
10	39.688	39.673	39.657	39.670	39.652
12	57.150	57.135	57.114	57.132	57.112
12-1	47.625	47.610	47.589	47.607	47.587
16	60.325	60.310	60.289	60.307	60.287
19	66.675	66.660	66.639	66.657	66.637
24	82.550	82.535	82.514	82.532	82.512
30	101.600	101.585	101.564	101.582	101.562

Bearing Series COM-M	DIMENSIONS IN INCHES				
	(A) Suggested Housing Bore For Press Fit of Metric Spherical Bearings				
	Bearing Outside Diameter + .0000 - .0007	Steel Housing		Aluminum Housing	
Max.		Min.	Max.	Min.	
3	.4724	.4718	.4713	.4717	.4711
5	.6299	.6293	.6288	.6292	.6286
6	.7087	.7081	.7076	.7080	.7074
8	.8661	.8655	.8650	.8654	.8648
10	1.0236	1.0230	1.0225	1.0229	1.0223
12	1.1811	1.1805	1.1799	1.1804	1.1797
14	1.3386	1.3380	1.3374	1.3379	1.3372
16	1.4961	1.4955	1.4949	1.4954	1.4947
18	1.6535	1.6529	1.6523	1.6528	1.6521
20	1.8110	1.8104	1.8096	1.8103	1.8095
22	1.9685	1.9679	1.9671	1.9678	1.9670
25	2.2047	2.2041	2.2033	2.2040	2.2032
30	2.5984	2.5978	2.5970	2.5977	2.5969

These tables are representative of Metal to Metal parts, please consult our engineering department regarding PTFE lined parts.

Bearing Installation

Spherical Bearing (chamfered) Installation

Proper installation of the bearing is important to prevent bearing failure as well as housing damage. The use of an arbor press or hydraulic press is recommended. A tool as shown in figure 1 is advised. All force is to be applied on the bearing race face (not on the ball). A lead chamfer or radius on the bearing and/or housing is vital.

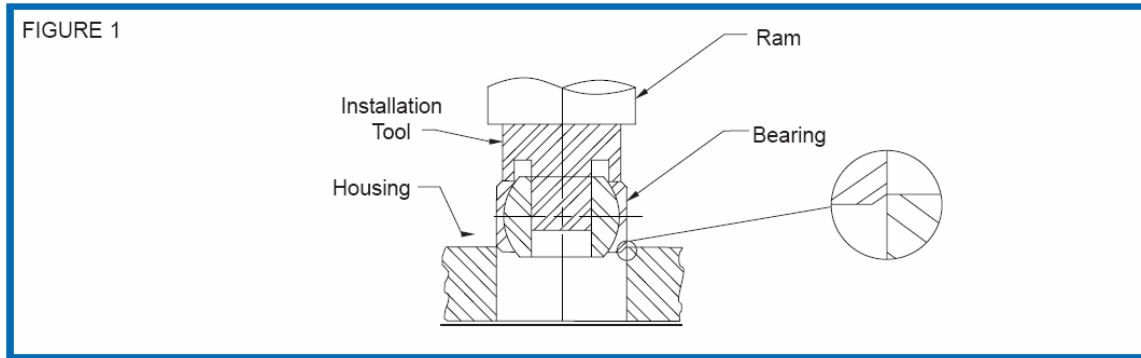

Spherical Bearing (grooved) Installation

The grooved (Grumman grooved) spherical bearings have a groove on each side of the bearing race face, leaving a small lip. Staking tools (as shown in figure 2) are then used to stake the lip over the chamfer edges of the housing. A typical arrangement consists of two identical anvils and one guide pin, which are secured by a setscrew in the bottom anvil.

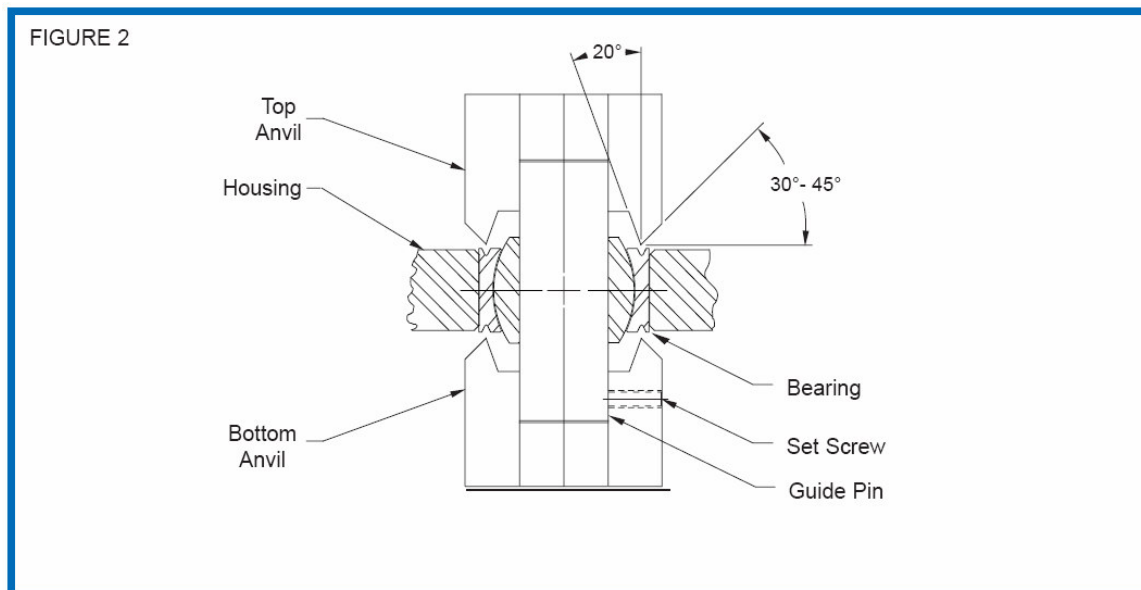

Procedure for Installation of Grooved Spherical Bearing

1. Install the bearing into the housing as shown in figure 1 and position the bearing symmetrical about the housing centerline.
2. Align bearing with staking tool and guide pin as shown in figure 2.
3. A trial stake assembly should be made to determine staking force necessary to meet thrust load requirements. Proper staking force is required because excessive pressure could result in bearing distortion along with life.
4. Pressure established by trial assembly is to be applied. After the first stake is completed, rotate the assembly 90° and re-apply. Repeat operation through a minimum of three rotations to insure 360° uniformity of stake.
5. After staking, a slight gap may exist between the race lip and housing chamfer. This slight gap (shown below) may not be cause for rejection if the bearing meets or exceeds the required thrust loads.

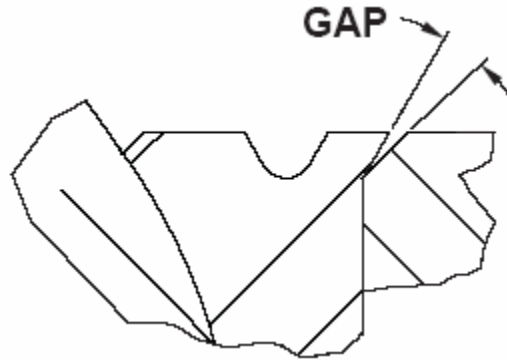

HOUSING CHAMFER - GROOVED BEARINGS

CHAMFER FOR GROOVE TYPES	
GROOVE TYPE A	.020 ± .005
GROOVE TYPE B	.030 ± .005
GROOVE TYPE C	.050 ± .005

STAKING GROOVE TYPES

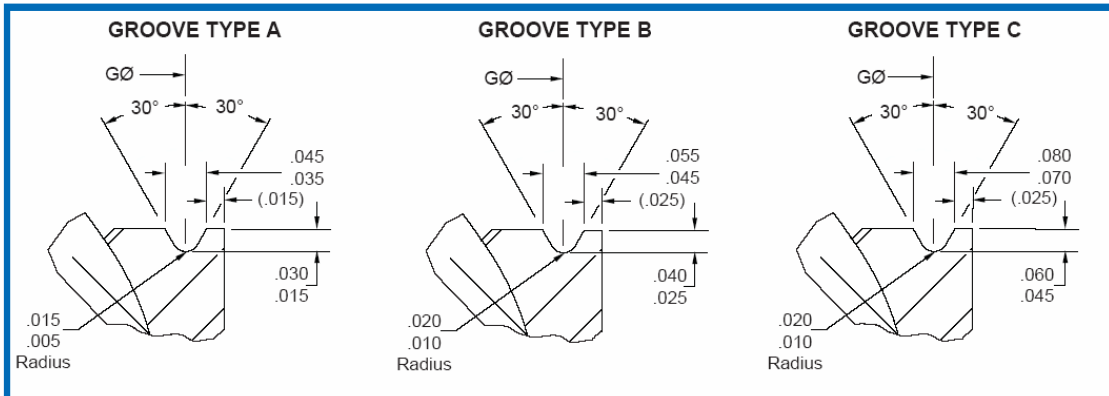

Groove Type Chart

Groove A

ANC-3TG
ANC-4TG
AWC-3TG
AWC-4TG
AWC-5TG
PWB-5TG
HAB-4TG
HAB-5TG
HAB-6TG
HAB-7TG
HAB-8TG

Groove B

ANC-5TG
ANC-6TG
ANC-7TG
AWC-6TG
AWC-7TG
AWC-8TG
AWC-9TG
AWC-10TG
PNB-5TG
PNB-6TG
PNB-7TG
PWB-6TG
PWB-7TG
PWB-8TG
PWB-9TG
PWB-10TG
HAB-10TG
HAB-12TG
HAB-14TG

Groove C

ANC-8TG
ANC-9TG
ANC-10TG
ANC-12TG
ANC-14TG
ANC-16TG
AWC-12TG
AWC-14TG
AWC-16TG
PNB-8TG
PNB-9TG
PNB-10TG
PNB-12TG
PWB-12TG