

# Terms Translations

A guide to translate common rod end industry terms from English to noted language. **This is a guide only.** Consultation with appropriate language references is recommended for best accuracy.

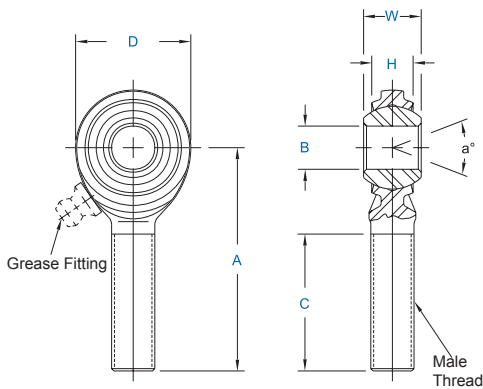

English	French	German	Italian	Portugese	Spanish
Aerospace	Aérospatial	Luftfahrt	Aerospaziale	Aeroespacial	Aeroespacial
Aluminum	Aluminium	Aluminium	Alluminio	Aluminio	Aluminio
Axial	Axiale	Axial	Assiali	Axial	Axial
Ball	Bague interieure	Innenringe	Anello Interno	anel interno	Esfera
Body	Corps	Gehaeuse	Testa	Corpo	cuerpo
<b>A</b> Base to Center	base pour centrer longueur	Abstand, Unterseite zur Mitte	lunghezza, da base al centro	distância, base ao centro	altura, base a centro
<b>B</b> Bore	Alesages	Bohrung	foro	Furo	agujero
Commercial		Kommerziell	uso generico	Comercial	Comercial
Chrome plate	chromage	verchromt	cromatura	Placa do cromo	cromado
<b>D</b> Diameter	Diametre	Durchmesser	Diametro	Diametro	Diametro
Female thread	Filetages Femelle	Innengewinde	Filettatura intera	Rosca Femea	rosca hembra
Grease Fitting	Graisneur	Schmiernippel	Ingrassatore	lubrificador	lubricador
<b>H</b> Head or Race Width	largeur de logement	Gehaeusebreite / Lagerschalenbreite	spessore testa / spessore boccola	largura externa do anel	anchura de la pista
Industrial grade	Industriel	Industrie-Qualitaet	qualità industriale		Industrial
Keyway	Rainure de Clavette	Keilnute	Scanalatura		cunero
Left Hand	gauche	Links	sinistra	inversa	Rosca izquierda
Load capacity	capacite de charges	belastbar	capacità di carico	Capacidade da carga	Capacidad de Carga
Male thread	Filetages male	Aussengewinde	maschio filettato	Rosca macho	Rosca macho
Military Specification	Spécifications Militaires	Militär-Vorschrift	Specifica Militare	Especificação Militar	Especificacion Militar
<b>Æ</b> Misalignment	angulaires	Kippwinkel	ribaltamento	inclinação	desalineamiento
Race	Logement	Lagerschale	boccola / anello esterno	anel externo	Pista
Radial	Radiale	Radial	Radiali	Radial	Radial
Right Hand	Normes, Droite	Rechts	a destra	normal	Rosca Derecha
Radial Static Load Capacity	charge statique	statische Tragzahl	Carico Statico	Capacidades de carga estatica	Carga radial maxima
Rod end	Embouts	Gelenkkopf, pl. Gelenkkoepfe	Teste a Snodo	Terminais Rotulares	Cabezas de articulación
Spherical bearing	Rotules	Gelenklager	Snodi Sferici	Rotulas	Rotula Esferica
Stainless steel	Acier Inoxydable	Rostfrei	Acciaio inox	Aco inox	Acero inoxidable
Steel	Acier	Stahl	Acciaio	Aco	Acero
Thread	Filetage	Gewinde	Filettatura	Rosca	Rosca
<b>C</b> Thread Length	longueur du filetage	Gewindelaenge	lunghezza del filetto	comprimento da rosca	Longitud de Rosca
<b>W</b> Width of ball	largeur bille	Innenringbreite	spessore anello interno	largura interna do anel	anchura de la esfera



Male Rod End

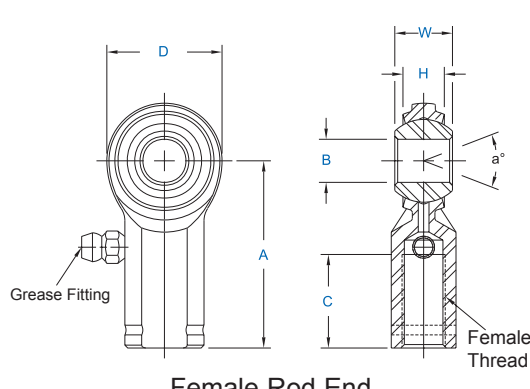

Female Rod End

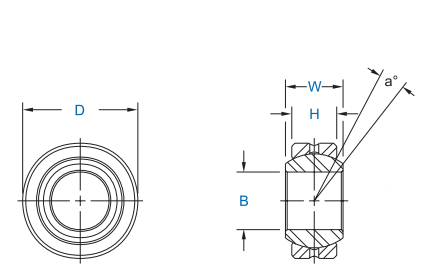

Spherical Bearing



Left Hand Thread



Right Hand Thread

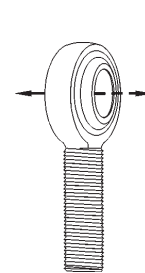
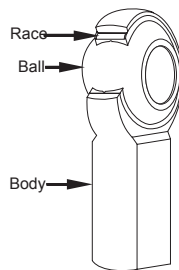

Axial



Radial