



# AURORA

The Motion-Transfer Specialists

## ROD END & SPHERICAL BEARING CATALOG & RESOURCE GUIDE

Effective August 21st, 2023, the Naval Air Warfare Center Aircraft Division (NAWCAD) has disapproved Timken Aurora's qualification status for SAE-AS81820 and SAE-AS81935 specifications. Timken Aurora is working diligently to get requalified.

COMMERCIAL | MILITARY | AIRCRAFT



# Contents

Page No.

Basic Information.....4-6

**Inch Rod End and Spherical Bearings**

SPM & SPB Male Rod Ends ..... 7

SPW & SPG Series Female Rod Ends ..... 8

CM & CB Series Male Rod Ends..... 9

CW & CG Series Female Rod Ends..... 10

VCM & VCB Series Male Rod Ends ..... 11

VCW & VCG Series Female Rod Ends ..... 12

CAM & CAB Series Male Rod Ends ..... 13

VCAM & VCAB Series Male Rod Ends ..... 14

BM & BB Series Male Rod Ends ..... 15

BW & BG Series Female Rod Ends ..... 16

MM & MB Series Male Rod Ends ..... 17

MW & MG Series Female Rod Ends..... 18

XM & XB Series Male Rod Ends ..... 19

KM & KB Series Male Rod Ends ..... 20

KW & KG Series Female Rod Ends ..... 21

SM & SB Series Male Rod Ends ..... 22

SW & SG Series Female Rod Ends ..... 23

CM-ET & CB-ET Series Stainless Steel Male Rod Ends ..... 24

CW-ET & CG-ET Series Stainless Steel Female Rod Ends ..... 25

SM-E & SB-E Series Stainless Steel Male Rod Ends ..... 26

SW-E & SG-E Series Stainless Steel Female Rod Ends ..... 27

Large Bore Series Male Rod Ends ..... 28

Large Bore Series Female Rod Ends..... 29

Large Bore Series Male Rod Ends ..... 30

Large Bore Series Female Rod Ends..... 31

AM & AB Series Male Rod Ends ..... 32

AW & AG Series Female Rod Ends ..... 33

XAM & XAB Series Male Rod Ends ..... 34

AM/XAM Series Special Size ..... 35

RAM, RAB, RXAM, RXAB Series Male Rod Ends ..... 36

RAM/RXAM Series Special Size ..... 37

Performance Racing Series..... 38-39

High Misalignment Series Male Rod Ends ..... 40

Linkages ..... 41

COM & HCOM Series Spherical Bearings ..... 42

COM-KH & HCOM-KH Series Spherical Bearings ..... 43

COM-E Series Spherical Bearings ..... 44

LCOM Series Large Size Spherical Bearings..... 45

MIB Series ..... 46

AIB Series..... 47

SIB Series..... 48

High Misalignment Series Spherical Bearings..... 49

Performance Racing Series..... 50-51

**Metric Rod End and Spherical Bearings**

CM-M & CB-M Series Male Rod Ends - Metric ..... 52

CW-M & CG-M Series Female Rod Ends - Metric ..... 53

## Contents

	Page No.
MM-M & MB-M Series Male Rod Ends - Metric .....	54
MW-M & MG-M Series Female Rod Ends - Metric.....	55
KM-M & KB-M Series Male Rod Ends - Metric.....	56
KW-M & KG-M Series Female Rod Ends - Metric.....	57
AM-M & AB-M Series Male Rod Ends - Metric.....	58
AW-M & AG-M Series Female Rod Ends - Metric.....	59
COM-M Series Spherical Bearings - Metric.....	60
Fractured Race Bearings.....	61
Spherical Plain Bearings .....	62-65
Angular Contact Spherical Plain Bearings.....	66
Fractured Race Bearing Option.....	67
Spherical Plain Bearings .....	68-71
Angular Contact Spherical Plain Bearings.....	72-73
Fractured Race Bearings Interchange Guide .....	74
HB Series .....	75
Rod End Studs .....	76
Jam Nuts .....	77
Lubrication Fittings .....	78
SAE Specification Bearings.....	79
ANC-T & ANC-TG Spherical Bearings .....	80-81
AWC-T & AWC-TG Spherical Bearings.....	82-83
ASM-T & ASB-T Male Rod Ends.....	84-85
ASW-T & ASG-T Female Rod Ends.....	86-87
ATM-T & ATB-T Male Rod Ends .....	88-89
ATW-T & ATG-T Female Rod Ends .....	90-91
ASM-ET & ASB-ET Male Rod Ends.....	92-93
ASW-ET & ASG-ET Female Rod Ends.....	94-95
ATM-ET & ATB-ET Male Rod Ends .....	96-97
ATW-ET & ATG-ET Female Rod Ends .....	98-99
AJB-TA/TC Straight Journal Bearings.....	100-101
AJB-TFA/TFC Flanged Journal Bearings.....	102-103
GMM-M & GMB-M Series Male Rod Ends.....	104
GMW-M & GMG-M Series Female Rod Ends.....	105
Aircraft and Military Special Products.....	106
Special Size Race Car Parts .....	107
Special Size Race Car Spherical Bearings .....	108
Technical Resources.....	109
Suggested Housing Bores.....	110-112
Suggested Shaft Sizes .....	113-114
Installation of Spherical Bearing.....	115
Installation of Spherical Bearing with Staking Grooves Tools and Staking Methods .....	116
Stake and Groove Type Chart.....	117
PTFE Liner Specifications .....	118
Temperature Limits.....	119
Frequently Asked Questions .....	120
Reference .....	121
Engineering Information .....	122
Terms Translations.....	123-124
2D and 3D CAD DRAWINGS of Timken Aurora Bearing Rod End and Spherical Bearings.....	125



## Manufacturing and worldwide supplier of the highest quality rod ends and spherical bearings - anywhere!

### GENERAL INFORMATION

Since 1971, Timken Aurora Bearing Company has been a major force in the rod end industry.

Known primarily for a high quality product and a strong commitment to customer service, the firm dramatically increased its market coverage and now serves nearly every industry and aerospace market. These markets include among others: textile and packaging machinery, machine tools, business machines, recreation and exercise equipment, agricultural and off highway vehicles, commercial transportation and high performance racing vehicles as well as military equipment and commercial air and spacecraft.

Over the years, Timken Aurora Bearing has retained its original business philosophy of furnishing a high quality product at competitive prices. In addition, the company's initial goals of providing prompt delivery and furnishing service with a personal touch have been rigidly maintained.

Timken Aurora Bearing offers a complete line of standard rod end and spherical bearings. We also design and manufacture special bearings to meet a variety of applications that require custom engineered units or special materials.

Now marketing products worldwide, Timken Aurora Bearing fields a very competent sales force that is available to assist and provide you with a practical and sound solution to rod end and spherical bearing application problems and challenges.

### PRODUCT INFORMATION ENGINEERING DATA AND ROD ENDS

Timken Aurora Bearing Company rod ends are, unless noted, manufactured utilizing two construction styles. They are of the two or three-piece type. Both are made with the solid, or one-piece, race construction method and feature the advantages of metal-to-metal contact between bearing components. (PTFE to metal interface may also be incorporated when specified).

The standard two-piece style consists of a body and precision ground heat treated steel ball. This type of construction allows the rod end body to carry a greater radial static load. This configuration also offers greater misalignment capabilities. A variety of materials and plating options for the component parts in this series are available. Any cold-formable steel in the stainless and alloy steel categories can be specified for the body, and all hardenable alloys such as 52100 and 440C stainless steel may be employed for the ball component.

The three-piece style consists of a body, ball and race. This type of unit, offering fully swaged bearing construction, features the advantages of optimized spherical conformity between the ball and race. It also offers flexibility in that many different types of materials can be interchanged in each component part, providing combinations that can be tailored to meet just about any application requirement.

The SPM/SPW series features a proprietary molded liner system with low friction and low moisture absorbing properties.

Consult our engineering department for materials to fit your special application. Materials used in the standard catalog items are outlined on the appropriate detail page.

### SPHERICAL BEARINGS

These bearings incorporate the single piece race type construction, providing optimized ball-to-race conformity. They can be re-lubricated through an annular groove in the outer race with two interconnecting holes positioned at 180 degrees. Various metals may also be substituted in these types of units to meet special requirements. Recommended housing bores are given on pages 110-112.

### PTFE LINED ROD ENDS AND SPHERICAL BEARINGS

Composite PTFE lined races are available as noted in most rod end bearing units and all spherical bearings. The steel race has a self-lubricating liner; a PTFE impregnated woven fabric, chemically bonded to the inner diameter of the race, and is denoted by the suffix "T". All Timken Aurora Bearing liner style options are maintenance free and offer improved frictional characteristics. They have been developed by Aurora engineers specifically for bearing use, and are exclusive to Timken Aurora Bearing products.

Except as noted, AT1400 is supplied as the standard liner in all commercial units. It is designed primarily to satisfy the demands of the commercial/industrial market as well as most high performance applications. This liner can be used in temperatures ranging from -65° to +250° F.

AT2100 is used in commercial units with stainless steel race construction. It is tailored for applications with aqueous environments.

Aurora 2 piece rod ends with the prefix "V" use Aurora's steel backed PTFE composite liner, resulting in the benefits of a PTFE lined bearing at an economical price.

Timken Aurora Bearing also has available a variety of alternate liner configurations to suit special requirements. Information on these and other liner configurations can be found on page 118.

## ULTIMATE RADIAL STATIC LOAD CAPACITY ROD ENDS

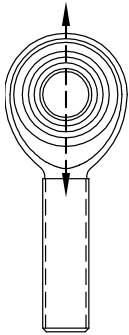

The ultimate radial static load capacity is based upon the minimum mechanical properties of the design configuration in the stressed area. The ultimate radial static load capacity called out in the rod end specification charts is defined as a single cycle, unidirectional applied load to cause ultimate failure. Operating loads should be based on the static load ratings, incorporating appropriate safety factors to suit the application. When a rod end or spherical bearing is to be applied in full rotation, the surface speed of the ball should be kept below 20 feet per minute or the rotational speed should be below 100 RPM, whichever is lower, with the operating loads not to exceed 10% of the ultimate radial static load.

Load ratings listed in the standard detail pages are applicable to rod ends supplied without grease fittings. Load ratings for units employing fittings may be affected due to lighter cross section in the stressed area. For information on the rod end radial static load ratings with fittings and other specific load rating information, consult the Timken Aurora Bearing engineering department.

## AXIAL STATIC LOAD CAPACITY ROD ENDS

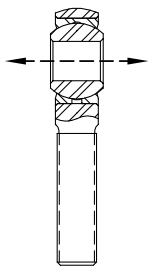

Axial static load capacity is the force that is applied through the bore of the ball. For Aurora two-piece rod ends, maximum axial static load capacity is recommended to be 15 percent of the ultimate radial static load capacity. For three-piece rod ends, maximum axial static load capacity is generally recommended as 10 percent of ultimate radial static load capacity. It should be noted, however, that on three-piece units factors such as race material, body material and dimensions may affect axial static load capacity. For further information, consult the Timken Aurora Bearing engineering department.

## RADIAL STATIC LIMIT LOAD CAPACITY SPHERICAL BEARINGS

Unless otherwise noted, radial static loads are maximum static based on the maximum permanent set in the bearing race of 0.2% of the ball diameter. If greater permanent set can be allowed or if alternate race materials are used consult our engineering department for change factors. Operating loads are based on the radial static load rating and appropriate safety factors should be utilized to suit the application.

Max axial load is recommended at 20 percent of the radial static load. Extreme care should be used on selecting a sufficiently strong housing to accept this type of bearing.

## BEARING MISALIGNMENT

A rod end or spherical bearing's ability to misalign is measured by the degree of angle the ball can accommodate without interference.

The angle of misalignment in a rod end is limited by the ball width and head diameter as shown in figure 1. This arrangement is called a clevis mount, and is the type represented in the standard rod end detail pages. If added misalignment is necessary, this can be accomplished by utilizing spacers between the clevis mounting and ball face, or by using special rod ends designed to meet specific requirements.

Misalignment angle in a spherical bearing is limited by the ball and race width with respect to the ball diameter, illustrated in figure 3. This is the mounting type represented in the standard detail pages for spherical bearings.

Mounting arrangements for spherical bearings such as shown in figures 2 through 4 are also used with rod ends. The misalignment angle is then calculated by selecting the proper formula.

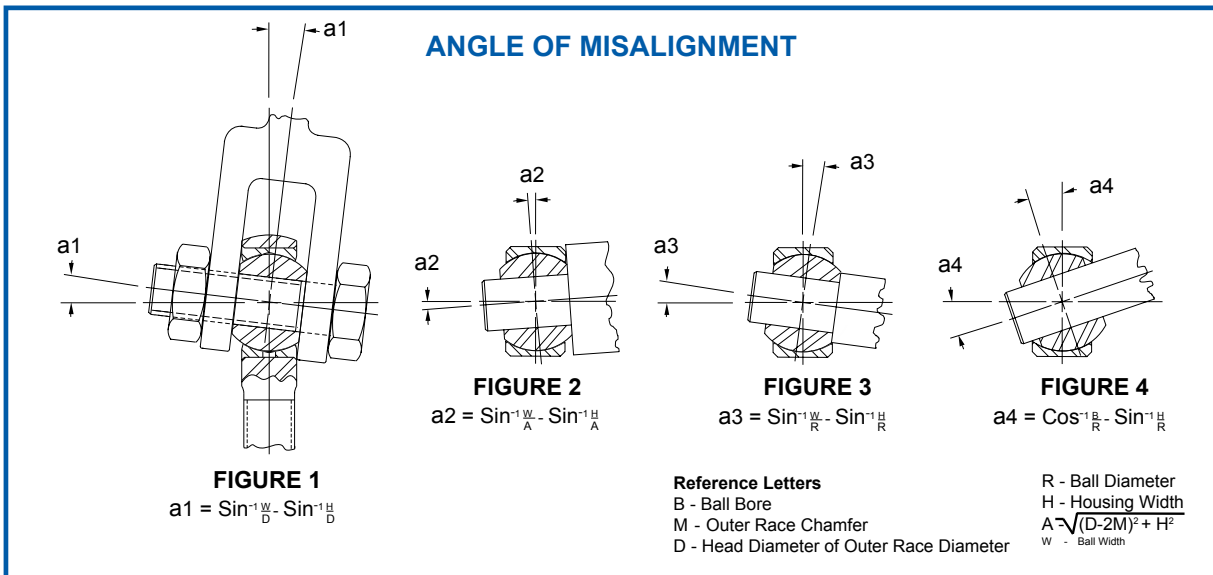

## 3-Piece Unit



**HOUSING**

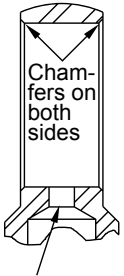

Chamfers on both sides

NOTE - Re-Lube hole for lubrication through shank of housing.

**INSERT**

Consists of BALL and RACE

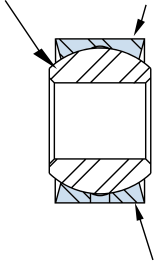

**Single piece race,** steel, heat-treated (optional), features swaged construction for maximum performance. Alternate race materials available to suit your application.

**ASSEMBLED HOUSING AND INSERT IN PRE-STAKING POSITION**

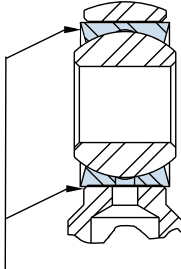

Note extension of race beyond width of housing in the pre-staking position.

**ASSEMBLED HOUSING AND INSERT IN STAKED POSITION**

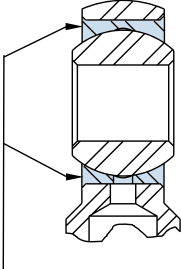

After staking, the sides of race have been upset into chamfers. Ball is subsequently loosened holding close tolerance fits between ball and race.

## 2-Piece Unit





Housing ready for swaging

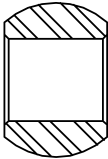

Precision ground ball - (available in alternate materials) - for close tolerance fits.

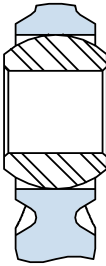

Housing and Ball in pre-swaging position.

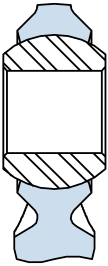

Sides of housing are closed around ball for maximum strength unit.

# SPM & SPB SERIES MALE ROD ENDS

Molded Race – Economy

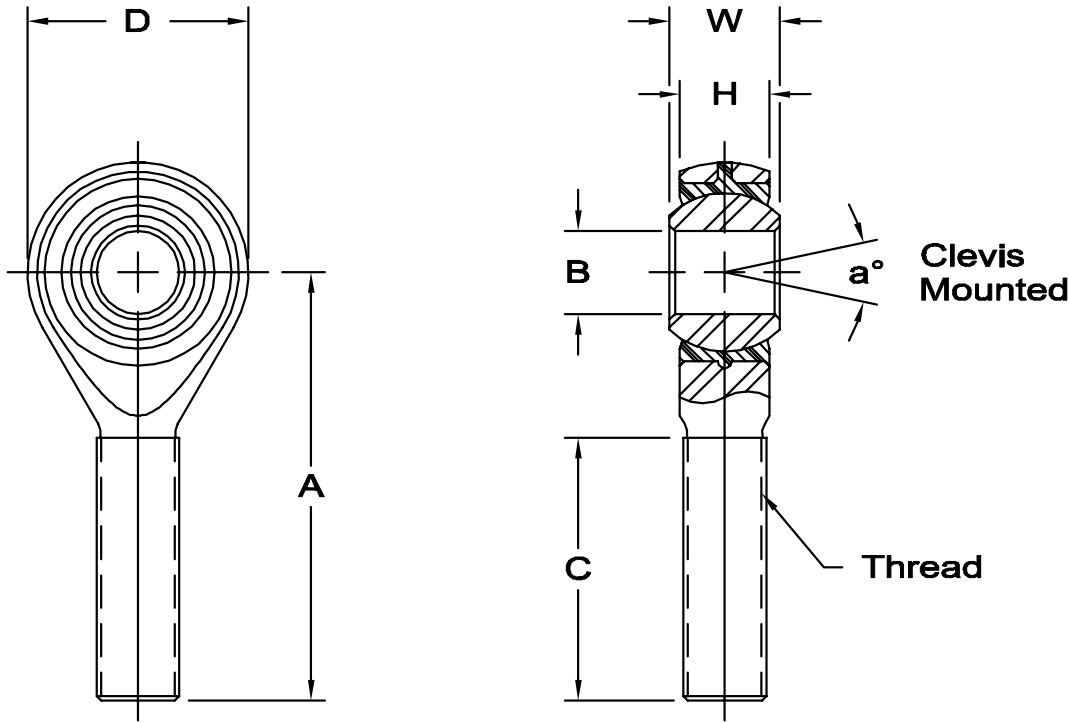

**Body** - Low carbon steel, protective coated for corrosion resistance.

**Ball** - Alloy steel, heat treated, hard chrome plated.

**Race** - Molded, self-lubricating, reinforced Nylon.

**Notes** - All sizes available with studs upon request.

This series features a molded race compound designed to provide low friction, low moisture absorbing properties.

timkenaurorabearing.com • Fax 630-859-0971

ROD END NO.		DIMENSIONS IN INCHES								a° Misalign. Angle	Ultimate Radial Static Load Capacity Lbs.	Approx. Brg. Wt. Lbs.
Right Hand	Left Hand	B + .0020 -.0000	W ± .005	H Ref.	A + .060 - .030	D ± .015	Ball Dia. Ref.	C ± .062	Thread UNF-2A			
SPM-3	SPB-3	.1900	.312	.250	1.250	.625	.437	.750	10-32	13	1,210	.02
SPM-4	SPB-4	.2500	.375	.281	1.562	.750	.500	1.000	1/4-28	16	2,470	.04
SPM-5	SPB-5	.3125	.437	.344	1.875	.875	.625	1.250	5/16-24	14	2,740	.07
SPM-6	SPB-6	.3750	.500	.406	1.938	1.000	.719	1.250	3/8-24	12	4,210	.11
SPM-7	SPB-7	.4375	.562	.437	2.125	1.125	.812	1.312	7/16-20	14	5,350	.15
SPM-8	SPB-8	.5000	.625	.500	2.438	1.312	.937	1.500	1/2-20	12	6,430	.23
SPM-10	SPB-10	.6250	.750	.562	2.625	1.500	1.125	1.625	5/8-18	16	8,300	.36
SPM-12	SPB-12	.7500	.875	.687	2.875	1.750	1.312	1.750	3/4-16	14	10,900	.57

ROD END NO.		DIMENSIONS IN MILLIMETERS								a° Misalign. Angle	Ultimate Radial Static Load Capacity Newtons	Approx. Brg. Wt. Grams
Right Hand	Left Hand	B + .051 -.000	W ± .13	H Ref.	A + 1.52 - .76	D ± .38	Ball Dia. Ref.	C ± 1.57	Thread UNF-2A			
SPM-3	SPB-3	4.826	7.92	6.35	31.75	15.88	11.10	19.05	10-32	13	5,382	10
SPM-4	SPB-4	6.350	9.53	7.14	39.67	19.05	12.70	25.40	1/4-28	16	10,987	18
SPM-5	SPB-5	7.938	11.10	8.74	47.63	22.23	15.88	31.75	5/16-24	14	12,188	32
SPM-6	SPB-6	9.525	12.70	10.31	49.23	25.40	18.26	31.75	3/8-24	12	18,726	49
SPM-7	SPB-7	11.113	14.27	11.10	53.98	28.58	20.62	33.33	7/16-20	14	23,797	67
SPM-8	SPB-8	12.700	15.88	12.70	61.93	33.32	23.80	38.10	1/2-20	12	28,601	105
SPM-10	SPB-10	15.875	19.05	14.27	66.68	38.10	28.58	41.28	5/8-18	16	36,918	165
SPM-12	SPB-12	19.050	22.23	17.45	73.03	44.45	33.32	44.45	3/4-16	14	48,483	258



# SPW & SPG SERIES FEMALE ROD ENDS

Molded Race – Economy

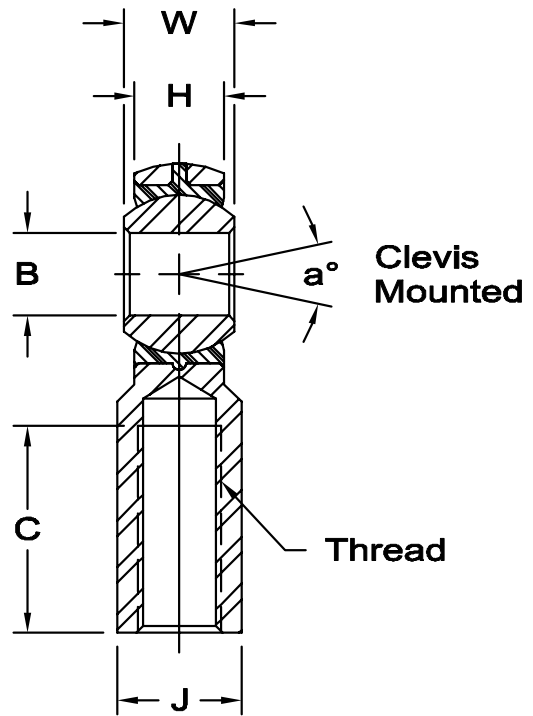
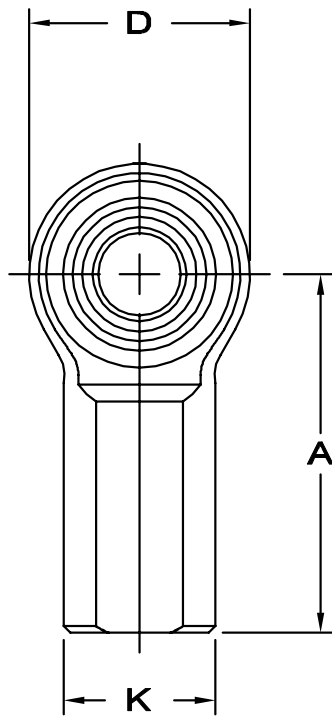

**Body** - Low carbon steel, protective coated for corrosion resistance.

**Ball** - Alloy steel, heat treated, hard chrome plated.

**Race** - Molded, self-lubricating, reinforced Nylon.

**Notes** - All sizes available with studs upon request.

This series features a molded race compound designed to provide low friction, low moisture absorbing properties.

timkenaurorabearing.com • Fax 630-859-0971

ROD END NO.		DIMENSIONS IN INCHES										a° Misalign. Angle	Ultimate Radial Static Load Capacity Lbs.	Approx. Brg. Wt. Lbs.
Right Hand	Left Hand	B + .0020 - .0000	W ± .005	H Ref.	A + .060 - .030	D ± .015	K ± .015	J ± .015	Ball Dia. Ref.	C ± .062	Thread UNF-2B			
SPW-3	SPG-3	.1900	.312	.250	1.062	.625	.406	.312	.437	.562	10-32	13	1,210	.04
SPW-4	SPG-4	.2500	.375	.281	1.312	.750	.469	.375	.500	.750	1/4-28	16	2,470	.06
SPW-5	SPG-5	.3125	.437	.344	1.375	.875	.500	.437	.625	.750	5/16-24	14	2,740	.08
SPW-6	SPG-6	.3750	.500	.406	1.625	1.000	.687	.562	.719	.937	3/8-24	12	4,100	.15
SPW-7	SPG-7	.4375	.562	.437	1.812	1.125	.750	.625	.812	1.062	7/16-20	14	5,350	.19
SPW-8	SPG-8	.5000	.625	.500	2.125	1.312	.875	.750	.937	1.187	1/2-20	12	6,430	.31
SPW-10	SPG-10	.6250	.750	.562	2.500	1.500	1.000	.875	1.125	1.500	5/8-18	16	8,300	.46
SPW-12	SPG-12	.7500	.875	.687	2.875	1.750	1.125	1.000	1.312	1.562	3/4-16	14	10,900	.67

ROD END NO.		DIMENSIONS IN MILLIMETERS										a° Misalign. Angle	Ultimate Radial Static Load Capacity Newtons	Approx. Brg. Wt. Grams
Right Hand	Left Hand	B + .051 - .000	W ± .13	H Ref.	A + 1.52 - .76	D ± .38	K ± .38	J ± .38	Ball Dia. Ref.	C ± 1.57	Thread UNF-2B			
SPW-3	SPG-3	4.826	7.92	6.35	26.97	15.88	10.31	7.92	11.10	14.27	10-32	13	5,382	17
SPW-4	SPG-4	6.350	9.53	7.14	33.32	19.05	11.91	9.53	12.70	19.05	1/4-28	16	10,987	27
SPW-5	SPG-5	7.938	11.10	8.74	34.93	22.23	12.70	11.10	15.88	19.05	5/16-24	14	12,188	35
SPW-6	SPG-6	9.525	12.70	10.31	41.28	25.40	17.45	14.27	18.26	23.80	3/8-24	12	18,237	66
SPW-7	SPG-7	11.113	14.27	11.10	46.02	28.58	19.05	15.88	20.62	26.97	7/16-20	14	23,797	87
SPW-8	SPG-8	12.700	15.88	12.70	53.98	33.32	22.23	19.05	23.80	30.15	1/2-20	12	28,601	142
SPW-10	SPG-10	15.875	19.05	14.27	63.50	38.10	25.40	22.23	28.58	38.10	5/8-18	16	36,918	210
SPW-12	SPG-12	19.050	22.23	17.45	73.03	44.45	28.58	25.40	33.32	44.45	3/4-12	14	48,483	305



# CM & CB SERIES MALE ROD ENDS

General Purpose - Economy

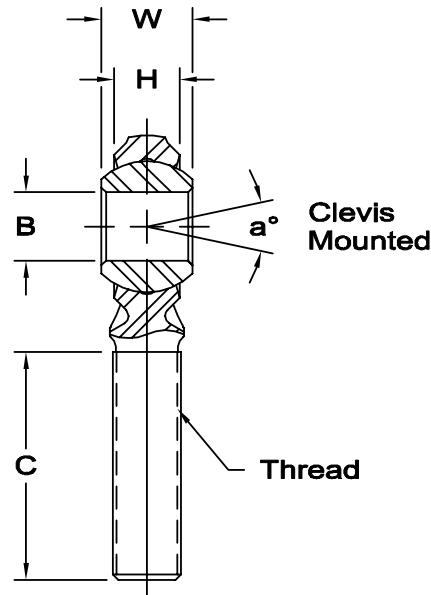
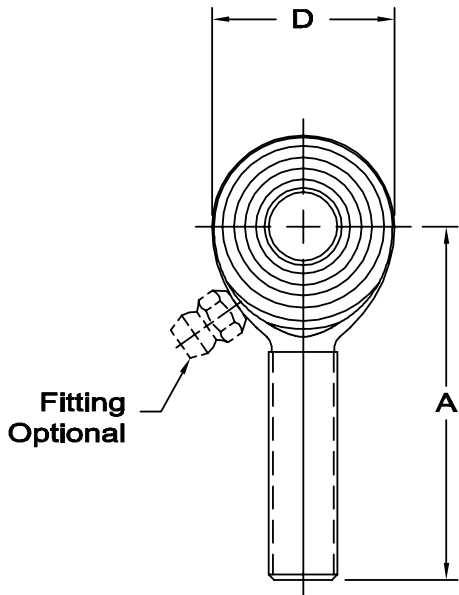

**Body** - Low carbon steel, protective coated for corrosion resistance.

**Ball** - Alloy steel, heat treated, hard chrome plated.

**Notes** - All sizes available with studs upon request.

Load ratings apply only to rod ends without grease fittings. For load ratings with fittings, please consult our engineering department.

\* Grease fittings not available on these sizes. Units are supplied without grease fittings. When a grease fitting is required, specify by adding suffix as designated.

Z Zerk type fitting  
F Flush type fitting

Ex: CM-6Z  
Ex: CM-6F

timkenaurorabearing.com • Fax 630-859-0971

ROD END NO.		DIMENSIONS IN INCHES								a° Misalign. Angle	Ultimate Radial Static Load Capacity Lbs.	Approx. Brg. Wt. Lbs.
Right Hand	Left Hand	B + .0025 -.0005	W ± .005	H Ref.	A ± .015	D Ref.	Ball Dia. Ref.	C + .062 -.031	Thread UNF-3A			
CM-3*	CB-3*	.1900	.312	.234	1.250	.625	.437	.750	10-32	20	1,204	.03
CM-4*	CB-4*	.2500	.375	.250	1.562	.750	.500	1.000	1/4-28	27	2,212	.04
CM-5*	CB-5*	.3125	.437	.312	1.875	.875	.625	1.250	5/16-24	22	3,577	.07
CM-6	CB-6	.3750	.500	.359	1.938	1.000	.719	1.250	3/8-24	22	5,068	.11
CM-7	CB-7	.4375	.562	.406	2.125	1.125	.812	1.375	7/16-20	21	6,345	.15
CM-8	CB-8	.5000	.625	.453	2.438	1.312	.937	1.500	1/2-20	20	8,338	.24
CM-10	CB-10	.6250	.750	.484	2.625	1.500	1.125	1.625	5/8-18	26	9,713	.36
CM-12	CB-12	.7500	.875	.593	2.875	1.750	1.312	1.750	3/4-16	24	14,207	.57

ROD END NO.		DIMENSIONS IN MILLIMETERS								a° Misalign. Angle	Ultimate Radial Static Load Capacity Newtons	Approx. Brg. Wt. Grams
Right Hand	Left Hand	B + .064 -.013	W ± .13	H Ref.	A ± .38	D Ref.	Ball Dia. Ref.	C + 1.57 -.79	Thread UNF-3A			
CM-3*	CB-3*	4.826	7.92	5.94	31.75	15.88	11.10	19.05	10-32	20	5,355	14
CM-4*	CB-4*	6.350	9.53	6.35	39.67	19.05	12.70	25.40	1/4-28	27	9,839	18
CM-5*	CB-5*	7.938	11.10	7.92	47.63	22.23	15.88	31.75	5/16-24	22	15,910	32
CM-6	CB-6	9.525	12.70	9.12	49.23	25.40	18.26	31.75	3/8-24	22	22,542	50
CM-7	CB-7	11.113	14.27	10.31	53.98	28.58	20.62	34.93	7/16-20	21	28,223	68
CM-8	CB-8	12.700	15.88	11.50	61.93	33.32	23.80	38.10	1/2-20	20	37,087	109
CM-10	CB-10	15.875	19.05	12.29	66.68	38.10	28.58	41.28	5/8-18	26	43,203	163
CM-12	CB-12	19.050	22.23	15.06	73.03	44.45	33.32	44.45	3/4-16	24	63,193	259



# CW & CG SERIES FEMALE ROD ENDS

General Purpose - Economy

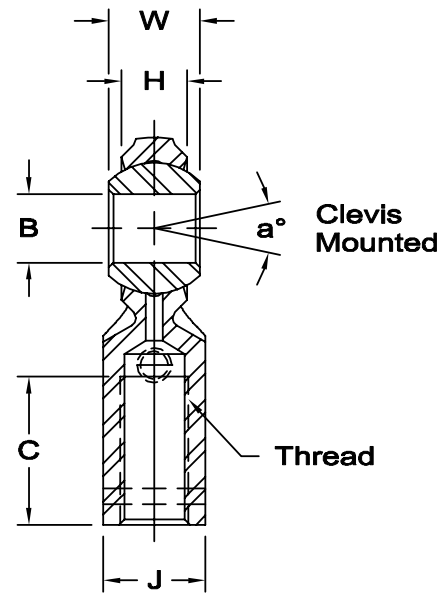
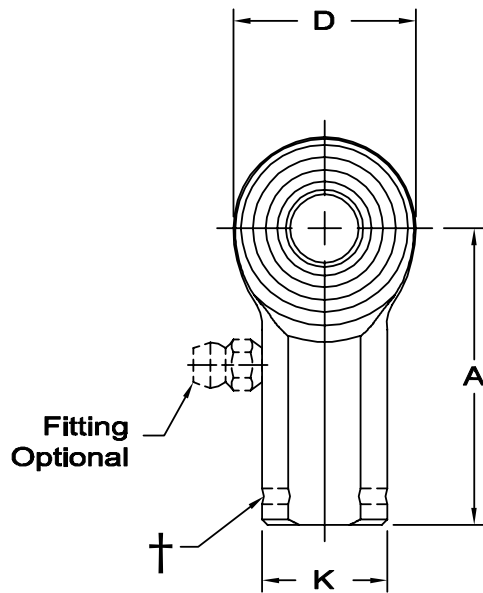

**Body** - Low carbon steel, protective coated for corrosion resistance.

**Ball** - Alloy steel, heat treated, hard chrome plated.

**Notes** - All sizes available with studs upon request.

†Left hand units have identification groove near end of shank.

\* Grease fittings not available on these sizes. Units are supplied without grease fittings. When a grease fitting is required, specify by adding suffix as designated.

Z Zerk type fitting  
F Flush type fitting

Ex: CW-6Z  
Ex: CW-6F

ROD END NO.		DIMENSIONS IN INCHES										a° Misalign. Angle	Ultimate Radial Static Load Capacity Lbs.	Approx. Brg. Wt. Lbs.
Right Hand	Left Hand†	B +.0025 -.0005	W ± .005	H Ref.	A ± .015	D Ref.	K ± .010	J ± .010	Ball Dia. Ref.	C + .062 - .031	Thread UNF-2B			
CW-3*	CG-3*	.1900	.312	.234	1.062	.625	.406	.312	.437	.500	10-32	20	2,079	.04
CW-4	CG-4	.2500	.375	.250	1.312	.750	.469	.375	.500	.687	1/4-28	27	3,208	.05
CW-5	CG-5	.3125	.437	.312	1.375	.875	.500	.437	.625	.687	5/16-24	22	3,824	.08
CW-6	CG-6	.3750	.500	.359	1.625	1.000	.687	.562	.719	.812	3/8-24	22	5,087	.13
CW-7	CG-7	.4375	.562	.406	1.812	1.125	.750	.625	.812	.937	7/16-20	21	6,385	.18
CW-8	CG-8	.5000	.625	.453	2.125	1.312	.875	.750	.937	1.062	1/2-20	20	9,096	.29
CW-10	CG-10	.6250	.750	.484	2.500	1.500	1.000	.875	1.125	1.375	5/8-18	26	9,713	.43
CW-12	CG-12	.7500	.875	.593	2.875	1.750	1.125	1.000	1.312	1.562	3/4-16	24	14,207	.65

ROD END NO.		DIMENSIONS IN MILLIMETERS										a° Misalign. Angle	Ultimate Radial Static Load Capacity Newtons	Approx. Brg. Wt. Grams
Right Hand	Left Hand†	B + .064 - .013	W ± .13	H Ref.	A ± .38	D Ref.	K ± .25	J ± .25	Ball Dia. Ref.	C + 1.57 - .79	Thread UNF-2B			
CW-3*	CG-3*	4.826	7.92	5.94	26.97	15.88	10.31	7.92	11.10	12.70	10-32	20	9,247	18
CW-4	CG-4	6.350	9.53	6.35	33.32	19.05	11.91	9.53	12.70	17.45	1/4-28	27	14,269	23
CW-5	CG-5	7.938	11.10	7.92	34.93	22.23	12.70	11.10	15.88	17.45	5/16-24	22	17,009	36
CW-6	CG-6	9.525	12.70	9.12	41.28	25.40	17.45	14.27	18.26	20.62	3/8-24	22	22,627	59
CW-7	CG-7	11.113	14.27	10.31	46.02	28.58	19.05	15.88	20.62	23.80	7/16-20	21	28,400	82
CW-8	CG-8	12.700	15.88	11.50	53.98	33.32	22.23	19.05	23.80	26.97	1/2-20	20	40,459	132
CW-10	CG-10	15.875	19.05	12.29	63.50	38.10	25.40	22.23	28.58	34.93	5/8-18	26	43,203	195
CW-12	CG-12	19.050	22.23	15.06	73.03	44.45	28.58	25.40	33.32	39.67	3/4-16	24	63,193	295

timkenaurorabearing.com • Fax 630-859-0971

# VCM & VCB SERIES MALE ROD ENDS

General Purpose - Economy - Self-Lubricating

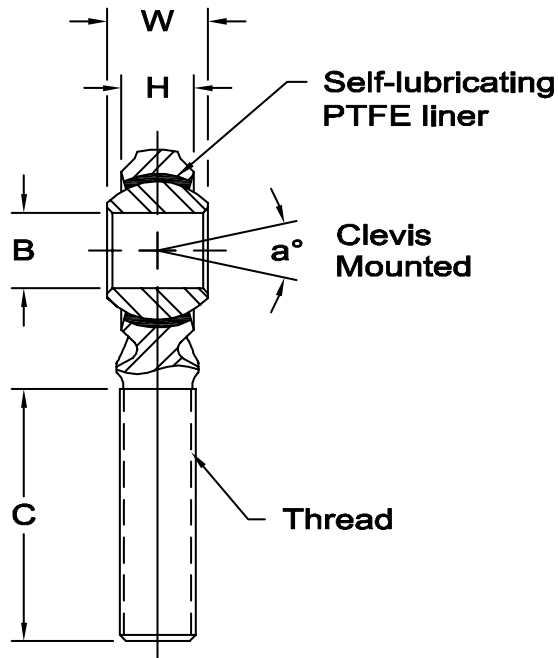
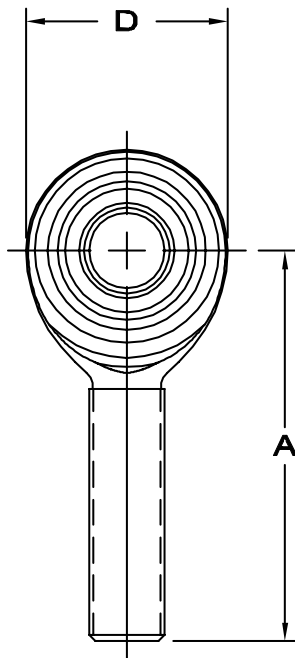

**Body** - Low carbon steel, protective coated for corrosion resistance.

**Ball** - Alloy steel, heat treated, hard chrome plated.

**Bushing** - Steel Backed, PTFE Composite

**Notes** - All sizes available with studs upon request.

timkenaurorabearing.com • Fax 630-859-0971

ROD END NO.		DIMENSIONS IN INCHES								a° Misalign. Angle	Ultimate Radial Static Load Capacity Lbs.	Approx. Brg. Wt. Lbs.
Right Hand	Left Hand	B + .0025 - .0005	W ± .005	H Ref.	A ± .015	D Ref.	Ball Dia. Ref.	C + .062 - .031	Thread UNF-3A			
VCM-5	VCB-5	.3125	.437	.312	1.875	.875	.593	1.250	5/16-24	18	2,623	.07
VCM-6	VCB-6	.3750	.500	.359	1.938	1.000	.687	1.250	3/8-24	18	3,643	.11
VCM-7	VCB-7	.4375	.562	.406	2.125	1.125	.781	1.375	7/16-20	17	4,464	.15
VCM-8	VCB-8	.5000	.625	.453	2.438	1.312	.875	1.500	1/2-20	16	7,229	.24
VCM-10	VCB-10	.6250	.750	.484	2.625	1.500	1.062	1.625	5/8-18	22	8,204	.36
VCM-12	VCB-12	.7500	.875	.593	2.875	1.750	1.250	1.750	3/4-16	20	12,280	.57

ROD END NO.		DIMENSIONS IN MILLIMETERS								a° Misalign. Angle	Ultimate Radial Static Load Capacity Newtons	Approx. Brg. Wt. Grams
Right Hand	Left Hand	B + .064 - .013	W ± .13	H Ref.	A ± .38	D Ref.	Ball Dia. Ref.	C + 1.57 - .79	Thread UNF-3A			
VCM-5	VCB-5	7.938	11.10	7.92	47.63	22.23	15.06	31.75	5/16-24	18	11,667	32
VCM-6	VCB-6	9.525	12.70	9.12	49.23	25.40	17.45	31.75	3/8-24	18	16,204	50
VCM-7	VCB-7	11.113	14.27	10.31	53.98	28.58	19.84	34.93	7/16-20	17	19,856	68
VCM-8	VCB-8	12.700	15.88	11.50	61.93	33.32	22.23	38.10	1/2-20	16	32,155	109
VCM-10	VCB-10	15.875	19.05	12.29	66.68	38.10	26.97	41.28	5/8-18	22	36,491	163
VCM-12	VCB-12	19.050	22.23	15.06	73.03	44.45	31.75	44.45	3/4-16	20	54,621	259



# VCW & VCG SERIES FEMALE ROD ENDS

General Purpose - Economy - Self-Lubricating

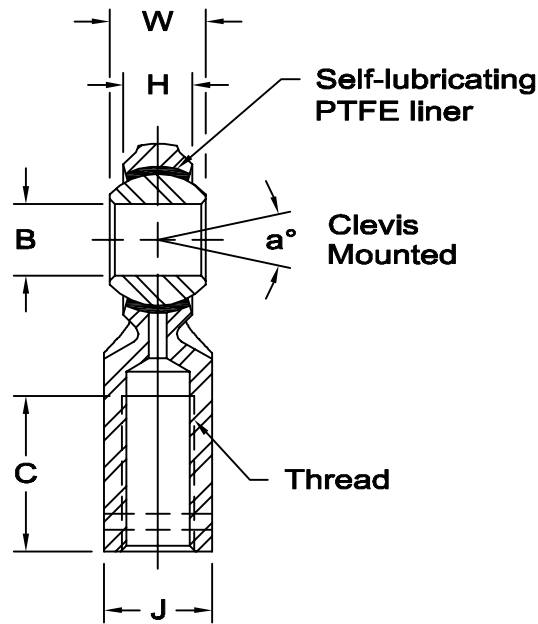
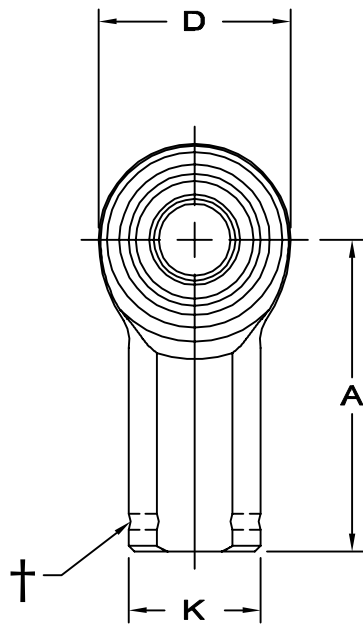

**Body** - Low carbon steel, protective coated for corrosion resistance.

**Ball** - Alloy steel, heat treated, hard chrome plated.

**Bushing** - Steel Backed, PTFE Composite

**Notes** - All sizes available with studs upon request.

timkenaurorabearing.com • Fax 630-859-0971

†Left hand units have identification groove near end of shank.

ROD END NO.		DIMENSIONS IN INCHES										a° Misalign. Angle	Ultimate Radial Static Load Capacity Lbs.	Approx. Brg. Wt. Lbs.
Right Hand	Left Hand†	B +.0025 -.0005	W ±.005	H Ref.	A ±.015	D Ref.	K ±.010	J ±.010	Ball Dia. Ref.	C +.062 -.031	Thread UNF-2B			
VCW-5	VCG-5	.3125	.437	.312	1.375	.875	.500	.437	.593	.687	5/16-24	18	2,623	.08
VCW-6	VCG-6	.3750	.500	.359	1.625	1.000	.687	.562	.687	.812	3/8-24	18	3,643	.13
VCW-7	VCG-7	.4375	.562	.406	1.812	1.125	.750	.625	.781	.937	7/16-20	17	4,464	.18
VCW-8	VCG-8	.5000	.625	.453	2.125	1.312	.875	.750	.875	1.062	1/2-20	16	7,229	.29
VCW-10	VCG-10	.6250	.750	.484	2.500	1.500	1.000	.875	1.062	1.375	5/8-18	22	8,204	.43
VCW-12	VCG-12	.7500	.875	.593	2.875	1.750	1.125	1.000	1.250	1.562	3/4-16	20	12,280	.65

ROD END NO.		DIMENSIONS IN MILLIMETERS										a° Misalign. Angle	Ultimate Radial Static Load Capacity Newtons	Approx. Brg. Wt. Grams
Right Hand	Left Hand†	B +.064 -.013	W ±.13	H Ref.	A ±.38	D Ref.	K ±.25	J ±.25	Ball Dia. Ref.	C + 1.57 -.79	Thread UNF-2B			
VCW-5	VCG-5	7.938	11.10	7.92	34.93	22.23	12.70	11.10	15.06	17.45	5/16-24	18	11,667	36
VCW-6	VCG-6	9.525	12.70	9.12	41.28	25.40	17.45	14.27	17.45	20.62	3/8-24	18	16,204	59
VCW-7	VCG-7	11.113	14.27	10.31	46.02	28.58	19.05	15.88	19.84	23.80	7/16-20	17	19,856	82
VCW-8	VCG-8	12.700	15.88	11.50	53.98	33.32	22.23	19.05	22.23	26.97	1/2-20	16	32,155	132
VCW-10	VCG-10	15.875	19.05	12.29	63.50	38.10	25.40	22.23	26.97	34.93	5/8-18	22	36,491	195
VCW-12	VCG-12	19.050	22.23	15.06	73.03	44.45	28.58	25.40	31.75	39.67	3/4-16	20	54,621	295

Studs available per notes and comments, page 76

# CAM & CAB SERIES MALE ROD ENDS

High Strength – Economy Series

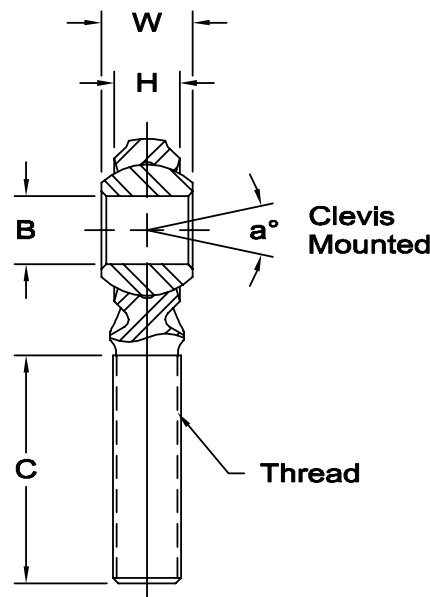
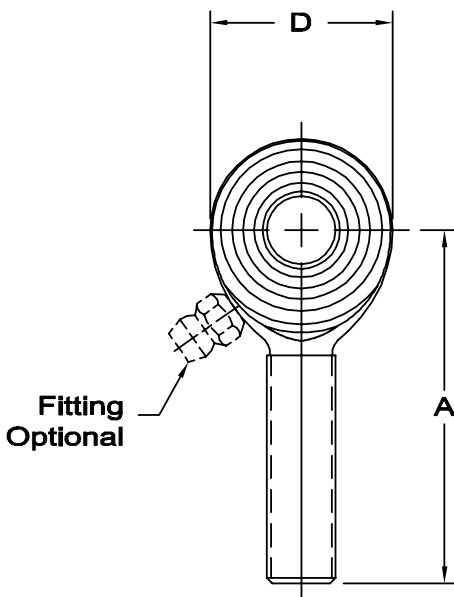

**Body** - Alloy steel, heat treated, protective coated for corrosion resistance.

**Ball** - Alloy steel, heat treated, hard chrome plated.

**Notes** - All sizes available with studs upon request.

Units are supplied without grease fittings. When a grease fitting is required, specify by adding suffix as designated.

Z Zerk type fitting                      Ex: CAM-6Z  
F Flush type fitting                      Ex: CAM-6F

Load ratings apply only to rod ends without grease fittings. For load ratings with fittings, please consult our engineering department.

\*Grease fitting not available on this size.

timkenaurorabearing.com • Fax 630-859-0971

ROD END NO.		DIMENSIONS IN INCHES								a° Misalign. Angle	Ultimate Radial Static Load Capacity Lbs.	Approx. Brg. Wt. Lbs.
Right Hand	Left Hand	B + .0025 - .0005	W + .005	H Ref.	A ± .015	D Ref.	Ball Dia. Ref.	C + .062 - .031	Thread UNF-3A			
* CAM-5	CAB-5	.3125	.437	.312	1.875	.875	.625	1.250	5/16-24	22	6,684	.07
CAM-6	CAB-6	.3750	.500	.359	1.938	1.000	.719	1.250	3/8-24	22	9,088	.11
CAM-7	CAB-7	.4375	.562	.406	2.125	1.125	.812	1.375	7/16-20	21	11,445	.15
CAM-8	CAB-8	.5000	.625	.453	2.438	1.312	.937	1.500	1/2-20	20	15,479	.24
CAM-10	CAB-10	.6250	.750	.484	2.625	1.500	1.125	1.625	5/8-18	26	17,470	.36
CAM-12	CAB-12	.7500	.875	.593	2.875	1.750	1.312	1.750	3/4-16	24	24,471	.57

ROD END NO.		DIMENSIONS IN MILLIMETERS								a° Misalign. Angle	Ultimate Radial Static Load Capacity Newtons	Approx. Brg. Wt. Grams
Right Hand	Left Hand	B + .064 - .013	W + .13	H Ref.	A + .38	D Ref.	Ball Dia. Ref.	C + 1.57 - .79	Thread UNF-3A			
CAM-5	CAB-5	7.938	11.10	7.92	47.63	22.23	15.88	31.75	5/16-24	22	30,531	32
CAM-6	CAB-6	9.525	12.70	9.12	49.23	25.40	18.26	31.75	3/8-24	22	40,423	50
CAM-7	CAB-7	11.113	14.27	10.31	53.98	28.58	20.62	34.93	7/16-20	21	50,907	68
CAM-8	CAB-8	12.700	15.88	11.50	61.93	33.32	23.80	38.10	1/2-20	20	68,851	109
CAM-10	CAB-10	15.875	19.05	12.29	66.68	38.10	28.58	41.28	5/8-18	26	77,707	163
CAM-12	CAB-12	19.050	22.23	15.06	73.03	44.45	33.32	44.45	3/4-16	24	108,847	259



# VCAM & VCAB SERIES MALE ROD ENDS

High Strength – Self Lubricating – Economy Series

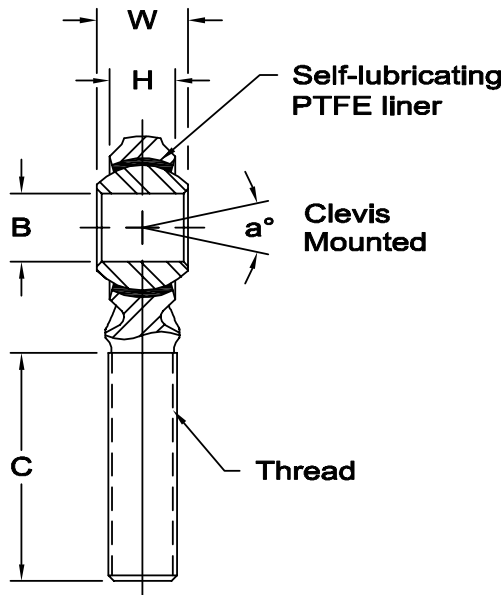
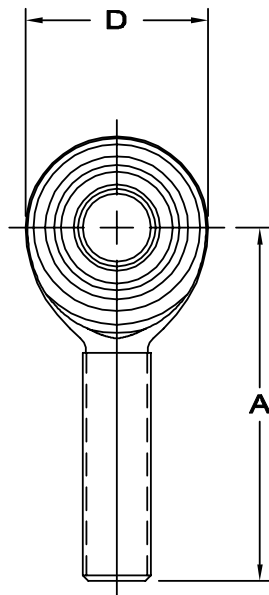

**Body** - Alloy steel, heat treated, protective coated for corrosion resistance.

**Ball** - Alloy steel, heat treated, hard chrome plated.

**Bushing** - Steel Backed, PTFE Composite

**Notes** - All sizes available with studs upon request.

timkenaurorabearing.com • Fax 630-859-0971

ROD END NO.		DIMENSIONS IN INCHES								a° Misalign. Angle	Ultimate Radial Static Load Capacity Lbs.	Approx. Brg. Wt. Lbs.
Right Hand	Left Hand	B + .0025 - .0005	W + .005	H Ref.	A ± .015	D Ref.	Ball Dia. Ref.	C + .062 - .031	Thread UNF-3A			
VCAM-5	VCAB-5	.3125	.437	.312	1.875	.875	.593	1.250	5/16-24	18	5,032	.07
VCAM-6	VCAB-6	.3750	.500	.359	1.938	1.000	.687	1.250	3/8-24	18	6,533	.11
VCAM-7	VCAB-7	.4375	.562	.406	2.125	1.125	.781	1.375	7/16-20	17	8,054	.15
VCAM-8	VCAB-8	.5000	.625	.453	2.438	1.312	.875	1.500	1/2-20	16	13,425	.24
VCAM-10	VCAB-10	.6250	.750	.484	2.625	1.500	1.062	1.625	5/8-18	22	14,755	.36
VCAM-12	VCAB-12	.7500	.875	.593	2.875	1.750	1.250	1.750	3/4-16	20	21,150	.57

ROD END NO.		DIMENSIONS IN MILLIMETERS								a° Misalign. Angle	Ultimate Radial Static Load Capacity Newtons	Approx. Brg. Wt. Grams
Right Hand	Left Hand	B + .064 - .013	W + .13	H Ref.	A + .38	D Ref.	Ball Dia. Ref.	C + 1.57 - .79	Thread UNF-3A			
VCAM-5	VCAB-5	7.938	11.10	7.92	47.63	22.23	15.06	31.75	5/16-24	18	22,382	32
VCAM-6	VCAB-6	9.525	12.70	9.12	49.23	25.40	17.45	31.75	3/8-24	18	29,059	50
VCAM-7	VCAB-7	11.113	14.27	10.31	53.98	28.58	19.84	34.93	7/16-20	17	35,824	68
VCAM-8	VCAB-8	12.700	15.88	11.50	61.93	33.32	22.23	38.10	1/2-20	16	59,714	109
VCAM-10	VCAB-10	15.875	19.05	12.29	66.68	38.10	26.97	41.28	5/8-18	22	65,630	163
VCAM-12	VCAB-12	19.050	22.23	15.06	73.03	44.45	31.75	44.45	3/4-16	20	94,075	259

Studs available per notes and comments, page 76

# BM & BB SERIES MALE ROD ENDS

General Purpose - Precision (Light Duty)

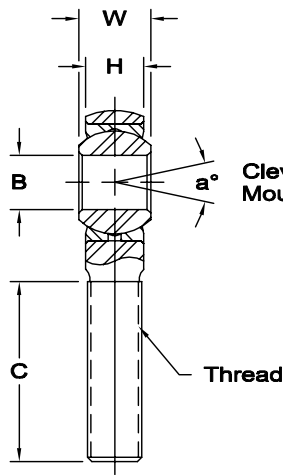
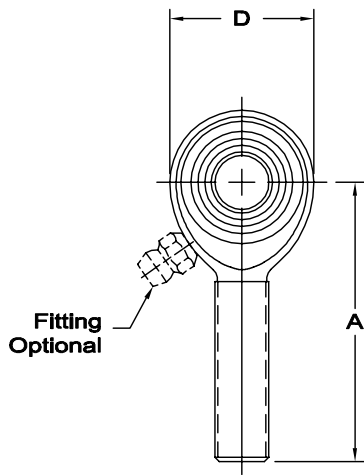

**Body** - Low carbon steel, protective coated for corrosion resistance.

**Race** - Sintered brass, oil impregnated.

**Ball** - Alloy steel, heat treated, hard chrome plated.

**Notes** - All sizes available with studs upon request.



Units are supplied without grease fittings. When grease fittings are required, specify by adding suffixes as designated.

Z Zerk type fitting Ex: BM-6Z

F Flush type fitting Ex: BM-6F

Load ratings apply only to rod ends without grease fittings. For load ratings with fittings, please consult our engineering department.

timkenaurorabearing.com • Fax 630-859-0971

ROD END NO.		DIMENSIONS IN INCHES								a° Misalign. Angle	Ultimate Radial Static Load Capacity Lbs.	Approx. Brg. Wt. Lbs.
Right Hand	Left Hand	B + .0015 - .0005	W + .000 - .005	H ± .005	A ± .015	D ± .010	Ball Dia. Ref.	C + .062 - .031	Thread UNF-3A			
BM-3	BB-3	.1900	.312	.250	1.250	.625	.437	.750	10-32	13	1,169	.03
BM-4	BB-4	.2500	.375	.281	1.562	.750	.500	1.000	1/4-28	16	2,158	.04
BM-5	BB-5	.3125	.437	.344	1.875	.875	.625	1.250	5/16-24	14	2,784	.07
BM-6	BB-6	.3750	.500	.406	1.938	1.000	.719	1.250	3/8-24	12	3,915	.11
BM-7	BB-7	.4375	.562	.437	2.125	1.125	.812	1.375	7/16-20	14	4,218	.16
BM-8	BB-8	.5000	.625	.500	2.438	1.312	.937	1.500	1/2-20	12	6,660	.25
BM-10	BB-10	.6250	.750	.562	2.625	1.500	1.125	1.625	5/8-18	16	7,364	.38
BM-12	BB-12	.7500	.875	.687	2.875	1.750	1.312	1.750	3/4-16	14	11,518	.60

ROD END NO.		DIMENSIONS IN MILLIMETERS								a° Misalign. Angle	Ultimate Radial Static Load Capacity Newtons	Approx. Brg. Wt. Grams
Right Hand	Left Hand	B + .038 - .013	W + .00 - .13	H ± .13	A ± .38	D ± .25	Ball Dia. Ref.	C + 1.57 - .79	Thread UNF-3A			
BM-3	BB-3	4.826	7.92	6.35	31.75	15.88	11.10	19.05	10-32	13	5,197	13
BM-4	BB-4	6.350	9.53	7.14	39.67	19.05	12.70	25.40	1/4-28	16	9,600	20
BM-5	BB-5	7.938	11.10	8.74	47.63	22.23	15.88	31.75	5/16-24	14	12,385	33
BM-6	BB-6	9.525	12.70	10.31	49.23	25.40	18.26	31.75	3/8-24	12	17,416	51
BM-7	BB-7	11.113	14.27	11.10	53.98	28.58	20.62	34.93	7/16-20	14	18,759	73
BM-8	BB-8	12.700	15.88	12.70	61.93	33.32	23.80	38.10	1/2-20	12	29,624	113
BM-10	BB-10	15.875	19.05	14.27	66.68	38.10	28.58	41.28	5/8-18	16	32,752	173
BM-12	BB-12	19.050	22.23	17.45	73.03	44.45	33.32	44.45	3/4-16	14	51,237	273



# BW & BG SERIES FEMALE ROD ENDS

General Purpose - Precision (Light Duty)



**Body** - Low carbon steel, protective coated for corrosion resistance.

**Race** - Sintered brass, oil impregnated.

**Ball** - Alloy steel, heat treated, hard chrome plated.

**Notes** - All sizes available with studs upon request.

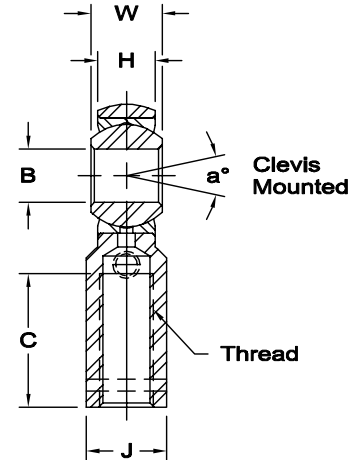
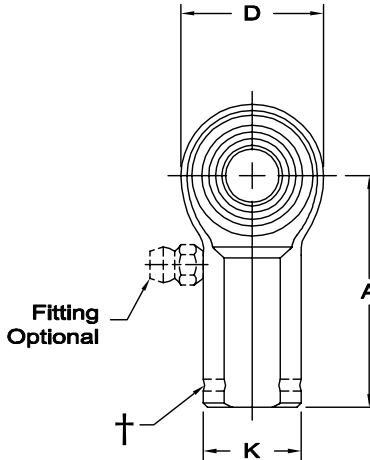

timkenaurorabearing.com • Fax 630-859-0971

Units are supplied without grease fittings. When a grease fitting is required, specify by adding suffix as designated.

Z Zerk type fitting

Ex: BW-6Z

F Flush type fitting

Ex: BW-6F

† Left hand units have identification groove near end of shank

ROD END NO.		DIMENSIONS IN INCHES										a° Misalign. Angle	Ultimate Radial Static Load Capacity Lbs.	Approx. Brg. Wt. Lbs.
Right Hand	Left Hand†	B + .0015 - .0005	W + .000 - .005	H ± .005	A ± .015	D ± .010	K ± .010	J ± .010	Ball Dia. Ref.	C + .062 - .031	Thread UNF-2B			
BW-3	BG-3	.1900	.312	.250	1.062	.625	.406	.312	.437	.562	10-32	13	1,531	.04
BW-4	BG-4	.2500	.375	.281	1.312	.750	.469	.375	.500	.750	1/4-28	16	2,539	.06
BW-5	BG-5	.3125	.437	.344	1.375	.875	.500	.437	.625	.750	5/16-24	14	3,133	.09
BW-6	BG-6	.3750	.500	.406	1.625	1.000	.687	.562	.719	.937	3/8-24	12	3,915	.15
BW-7	BG-7	.4375	.562	.437	1.812	1.125	.750	.625	.812	1.062	7/16-20	14	4,218	.20
BW-8	BG-8	.5000	.625	.500	2.125	1.312	.875	.750	.937	1.187	1/2-20	12	6,660	.33
BW-10	BG-10	.6250	.750	.562	2.500	1.500	1.000	.875	1.125	1.500	5/8-18	16	7,364	.48
BW-12	BG-12	.7500	.875	.687	2.875	1.750	1.125	1.000	1.312	1.750	3/4-16	14	11,518	.72

ROD END NO.		DIMENSIONS IN MILLIMETERS										a° Misalign. Angle	Ultimate Radial Static Load Capacity Newtons	Approx. Brg. Wt. Grams
Right Hand	Left Hand†	B + .038 - .013	W + .00 - .13	H ± .13	A ± .38	D ± .25	K ± .25	J ± .25	Ball Dia. Ref.	C + 1.57 - .79	Thread UNF-2B			
BW-3	BG-3	4.826	7.92	6.35	26.97	15.88	10.31	7.92	11.10	14.27	10-32	13	6,805	17
BW-4	BG-4	6.350	9.53	7.14	33.32	19.05	11.91	9.53	12.70	19.05	1/4-28	16	11,297	27
BW-5	BG-5	7.938	11.10	8.74	34.93	22.23	12.70	11.10	15.88	19.05	5/16-24	14	13,934	42
BW-6	BG-6	9.525	12.70	10.31	41.28	25.40	17.45	14.27	18.26	23.80	3/8-24	12	17,416	69
BW-7	BG-7	11.113	14.27	11.10	46.02	28.58	19.05	15.88	20.62	26.97	7/16-20	14	18,759	90
BW-8	BG-8	12.700	15.88	12.70	53.98	33.32	22.23	19.05	23.80	30.15	1/2-20	12	29,624	149
BW-10	BG-10	15.875	19.05	14.27	63.50	38.10	25.40	22.23	28.58	38.10	5/8-18	16	32,752	216
BW-12	BG-12	19.050	22.23	17.45	73.03	44.45	28.58	25.40	33.32	44.45	3/4-16	14	51,237	328



# MM & MB SERIES MALE ROD ENDS

General Purpose - Precision (PTFE Liners Available)

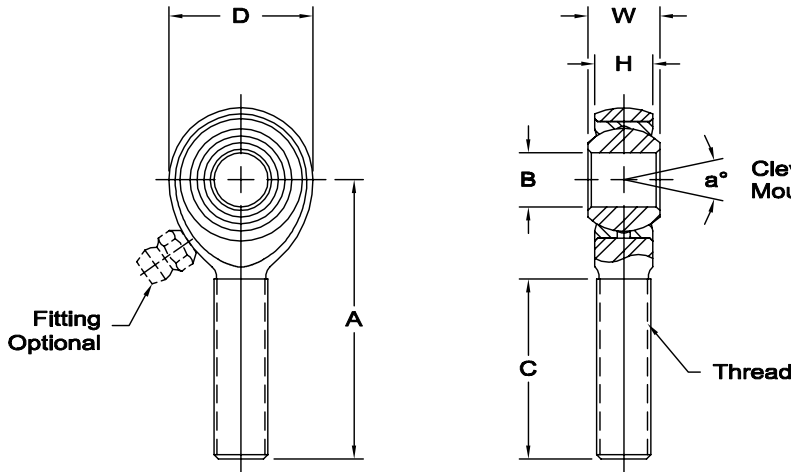

**Body** - Low carbon steel, protective coated for corrosion resistance. No. 16 series standard body is alloy steel not heat treated.

**Race** - Low carbon steel, protective coated for corrosion resistance.

**Ball** - Alloy steel, heat treated, hard chrome plated.

**Notes** - All sizes available with studs upon request.



- \* Check availability.
- \*\* Grease fitting not available.
- 1 Threads 6-32 UNC.
- 2 Threads 1-14 UNS.
- 3 Tolerance variation: "D" ± .020, "A" ± .020, "B" + .0035, - .0005, "H" ± .010
- 4 Tolerance variation: "D" ± .51, "A" ± .51, "B" + .089, - .013, "H" ± .25

Units are supplied without grease fittings. When grease fittings are required, specify by adding suffixes as designated.

- Z Zerk type fitting Ex: MM-6Z
- F Flush type fitting Ex: MM-6F
- T PTFE liner Ex: MM-6T

Load ratings apply only to rod ends without grease fittings. For load ratings with fittings, please consult our engineering department.

timkenaurorabearing.com • Fax 630-859-0971

ROD END NO.		DIMENSIONS IN INCHES								a° Misalign. Angle	Ultimate Radial Static Load Capacity Lbs.	Approx. Brg. Wt. Lbs.	
Right Hand	Left Hand	B + .0015 - .0005	W + .000 - .005	H ± .005	A ± .015	D ± .010	Ball Dia. Ref.	C + .062 - .031	Thread UNF-3A				
**	MM-2	MB-2	.1250	.250	.187	.937	.500	.312	.562	6-32 <sub>1</sub>	16	502	.01
	MM-3	MB-3	.1900	.312	.250	1.250	.625	.437	.750	10-32	13	1,169	.03
	MM-4	MB-4	.2500	.375	.281	1.562	.750	.500	1.000	1/4-28	16	2,158	.04
	MM-5	MB-5	.3125	.437	.344	1.875	.875	.625	1.250	5/16-24	14	2,784	.07
	MM-6	MB-6	.3750	.500	.406	1.938	1.000	.719	1.250	3/8-24	12	3,915	.11
	MM-7	MB-7	.4375	.562	.437	2.125	1.125	.812	1.375	7/16-20	14	4,218	.16
	MM-8	MB-8	.5000	.625	.500	2.438	1.312	.937	1.500	1/2-20	12	6,660	.25
	MM-10	MB-10	.6250	.750	.562	2.625	1.500	1.125	1.625	5/8-18	16	7,364	.38
	MM-12	MB-12	.7500	.875	.687	2.875	1.750	1.312	1.750	3/4-16	14	11,518	.60
*	MM-14	MB-14	.8750	.875	.765	3.375	2.000	1.375	2.000	7/8-14	7	18,476	.91
*	MM-14-1	MB-14-1	.8750	.875	.687	3.375	2.000	1.312	1.875	7/8-14	12	22,843	.91
3	MM-16	MB-16	1.0000	1.375	1.000	4.125	2.750	1.875	2.125	1 1/4-12	17	43,541	2.41
3	MM-16-1	MB-16-1	1.0000	1.375	1.000	4.125	2.750	1.875	2.125	1-14 <sub>2</sub>	17	43,541	2.13
3	MM-16-2	MB-16-2	1.0000	1.375	1.000	4.125	2.750	1.875	2.125	1-12	17	43,541	2.13

ROD END NO.		DIMENSIONS IN MILLIMETERS								a° Misalign. Angle	Ultimate Radial Static Load Capacity Newtons	Approx. Brg. Wt. Grams	
Right Hand	Left Hand	B + .038 - .013	W + .00 - .13	H ± .13	A ± .38	D ± .25	Ball Dia. Ref.	C + 1.57 - .79	Thread UNF-3A				
**	MM-2	MB-2	3.175	6.35	4.75	23.80	12.70	7.92	14.27	6-32 <sub>1</sub>	16	2,236	6
	MM-3	MB-3	4.826	7.92	6.35	31.75	15.88	11.10	19.05	10-32	13	5,197	13
	MM-4	MB-4	6.350	9.53	7.14	39.67	19.05	12.70	25.40	1/4-28	16	9,600	20
	MM-5	MB-5	7.938	11.10	8.74	47.63	22.23	15.88	31.75	5/16-24	14	12,385	33
	MM-6	MB-6	9.525	12.70	10.31	49.23	25.40	18.26	31.75	3/8-24	12	17,416	51
	MM-7	MB-7	11.113	14.27	11.10	53.98	28.58	20.62	34.93	7/16-20	14	18,759	73
	MM-8	MB-8	12.700	15.88	12.70	61.93	33.32	23.80	38.10	1/2-20	12	29,624	113
	MM-10	MB-10	15.875	19.05	14.27	66.68	38.10	28.58	41.28	5/8-18	16	32,752	173
	MM-12	MB-12	19.050	22.23	17.45	73.03	44.45	33.32	44.45	3/4-16	14	51,237	273
*	MM-14	MB-14	22.225	22.23	19.43	85.73	50.80	34.93	50.80	7/8-14	7	82,185	411
*	MM-14-1	MB-14-1	22.225	22.23	17.45	85.73	50.80	33.32	47.63	7/8-14	12	101,601	411
4	MM-16	MB-16	25.400	34.93	25.40	104.78	69.85	47.63	53.98	1 1/4-12	17	193,670	1,091
4	MM-16-1	MB-16-1	25.400	34.93	25.40	104.78	69.85	47.63	53.98	1-14 <sub>2</sub>	17	193,670	965
4	MM-16-2	MB-16-2	25.400	34.93	25.40	104.78	69.85	47.63	53.98	1-12	17	193,670	965

Studs available per notes and comments, page 76



# MW & MG SERIES FEMALE ROD ENDS

General Purpose - Precision (PTFE Liners Available)



**Body** - Low carbon steel, protective coated for corrosion resistance. No. 16 series standard body is alloy steel not heat treated.

**Race** - Low carbon steel, protective coated for corrosion resistance.

**Ball** - Alloy steel, heat treated, hard chrome plated.

**Notes** - All sizes available with studs upon request.

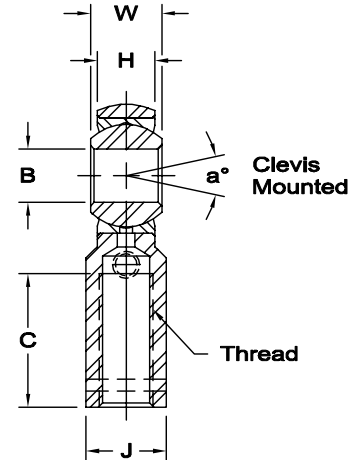
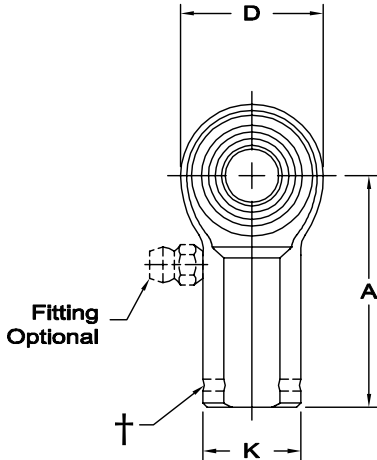

timkenaurorabearing.com • Fax 630-859-0971

\* Check for availability

† Left hand units have identification groove near end of shank

1 Threads 6-32 UNC

2 Threads 1-14 UNS

3 Tolerance variation: "D" ± .020, "A" ± .020 "B" + .0035, -.0005, "H" ± .010, "K" ± .015, "J" ± .015

4 Tolerance variation: "D" ± .51, "A" ± .51 "B" + .089, -.013, "H" ± .25, "K" ± .38, "J" ± .38

\*\* Grease fitting not available. Units are supplied without grease fittings. When a grease fitting is required, specify by adding suffix as designated.

Z Zerk type fitting

Ex: MW-6Z

F Flush type fitting

Ex: MW-6F

T PTFE liner

Ex: MW-6T

ROD END NO.		DIMENSIONS IN INCHES										a° Misalign. Angle	Ultimate Radial Static Load Capacity Lbs.	Approx. Brg. Wt. Lbs.	
Right Hand	Left Hand†	B +.0015 -.0005	W +.000 -.005	H ±.005	A ±.015	D ±.010	K ±.010	J ±.010	Ball Dia. Ref.	C +.062 -.031	Thread UNF-2B				
**	MW-2	MG-2	.1250	.250	.187	.812	.500	.312	.250	.312	.437	6-32 <sub>1</sub>	16	1,202	.02
	MW-3	MG-3	.1900	.312	.250	1.062	.625	.406	.312	.437	.562	10-32	13	1,531	.04
	MW-4	MG-4	.2500	.375	.281	1.312	.750	.469	.375	.500	.750	1/4-28	16	2,539	.06
	MW-5	MG-5	.3125	.437	.344	1.375	.875	.500	.437	.625	.750	5/16-24	14	3,133	.09
	MW-6	MG-6	.3750	.500	.406	1.625	1.000	.687	.562	.719	.937	3/8-24	12	3,915	.15
	MW-7	MG-7	.4375	.562	.437	1.812	1.125	.750	.625	.812	1.062	7/16-20	14	4,218	.20
	MW-8	MG-8	.5000	.625	.500	2.125	1.312	.875	.750	.937	1.187	1/2-20	12	6,660	.33
	MW-10	MG-10	.6250	.750	.562	2.500	1.500	1.000	.875	1.125	1.500	5/8-18	16	7,364	.48
	MW-12	MG-12	.7500	.875	.687	2.875	1.750	1.125	1.000	1.312	1.750	3/4-16	14	11,518	.72
*	MW-14	MG-14	.8750	.875	.765	3.375	2.000	1.300	1.125	1.375	1.875	7/8-14	7	18,476	1.03
*	MW-14-1	MG-14-1	.8750	.875	.687	3.500	2.000	1.312	1.187	1.312	1.812	7/8-14	12	22,843	1.03
3	MW-16	MG-16	1.0000	1.375	1.000	4.125	2.750	1.625	1.500	1.875	2.125	1 1/4-12	17	40,889	2.13
3	MW-16-1	MG-16-1	1.0000	1.375	1.000	4.125	2.750	1.625	1.500	1.875	2.125	1-14 <sub>2</sub>	17	43,541	2.41
3	MW-16-2	MG-16-2	1.0000	1.375	1.000	4.125	2.750	1.625	1.500	1.875	2.125	1-12	17	43,541	2.41

ROD END NO.		DIMENSIONS IN MILLIMETERS										a° Misalign. Angle	Ultimate Radial Static Load Capacity Newtons	Approx. Brg. Wt. Grams	
Right Hand	Left Hand†	B +.038 -.013	W +.00 -.13	H ±.13	A ±.38	D ±.25	K ±.25	J ±.25	Ball Dia. Ref.	C + 1.57 -.79	Thread UNF-2B				
**	MW-2	MG-2	3.175	6.35	4.75	20.62	12.70	7.92	6.35	7.92	11.10	6-32 <sub>1</sub>	16	5,344	9
	MW-3	MG-3	4.826	7.92	6.35	26.97	15.88	10.31	7.92	11.10	14.27	10-32	13	6,805	17
	MW-4	MG-4	6.350	9.53	7.14	33.32	19.05	11.91	9.53	12.70	19.05	1/4-28	16	11,297	27
	MW-5	MG-5	7.938	11.10	8.74	34.93	22.23	12.70	11.10	15.88	19.05	5/16-24	14	13,934	42
	MW-6	MG-6	9.525	12.70	10.31	41.28	25.40	17.45	14.27	18.26	23.80	3/8-24	12	17,416	69
	MW-7	MG-7	11.113	14.27	11.10	46.02	28.58	19.05	15.88	20.62	26.97	7/16-20	14	18,759	90
	MW-8	MG-8	12.700	15.88	12.70	53.98	33.32	22.23	19.05	23.80	30.15	1/2-20	12	29,624	149
	MW-10	MG-10	15.875	19.05	14.27	63.50	38.10	25.40	22.23	28.58	38.10	5/8-18	16	32,752	216
	MW-12	MG-12	19.050	22.23	17.45	73.03	44.45	28.58	25.40	33.32	44.45	3/4-16	14	51,237	328
*	MW-14	MG-14	22.225	22.23	19.43	85.73	50.80	33.02	28.58	34.93	47.63	7/8-14	7	82,185	67
*	MW-14-1	MG-14-1	22.225	22.23	17.45	88.90	50.80	33.32	30.15	33.32	46.02	7/8-14	12	101,601	467
4	MW-16	MG-16	25.400	34.93	25.40	104.78	69.85	41.28	38.10	47.63	53.98	1 1/4-12	17	193,670	964
4	MW-16-1	MG-16-1	25.400	34.93	25.40	104.78	69.85	41.28	38.10	47.63	53.98	1-14 <sub>2</sub>	17	193,670	1,093
4	MW-16-2	MG-16-2	25.400	34.93	25.40	104.78	69.85	41.28	38.10	47.63	53.98	1-12	17	193,670	1,093

# XM & XB SERIES MALE ROD ENDS

Extra Strength – Heavy Duty Shank (PTFE Liners Available)

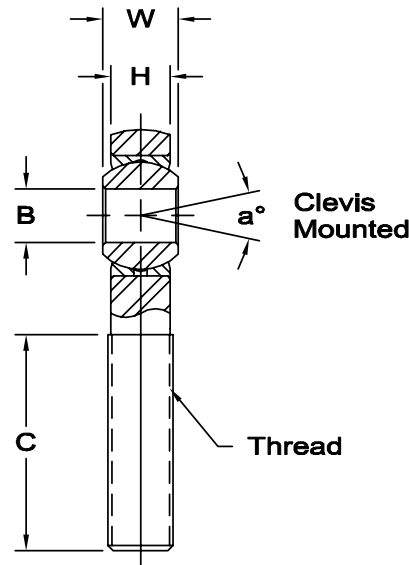
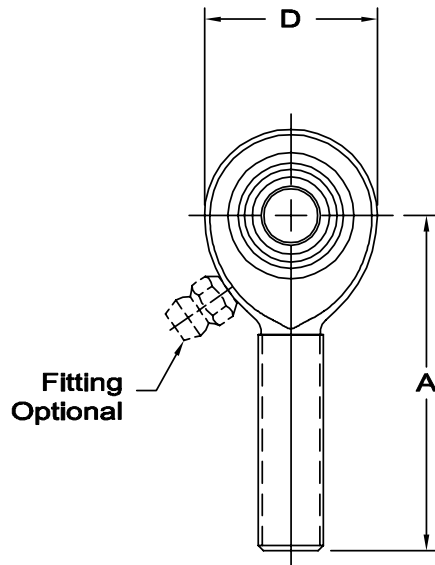

**Body** - Low carbon steel, protective coated for corrosion resistance.

**Race** - Alloy steel, heat treated protective coated for corrosion resistance. (Low carbon steel with PTFE liners.)

**Ball** - Alloy steel, heat treated, hard chrome plated.

**Notes** - All sizes available with studs upon request.

Load ratings apply only to rod ends without grease fittings. For load ratings with fittings, please consult our engineering department.

Units are supplied without grease fittings. When a grease fitting is required, specify by adding suffix as designated.

- Z Zerk type fitting Ex: XM-6Z
- F Flush type fitting Ex: XM-6F
- T PTFE Liner Ex: XM-6T

timkenaurorabearing.com • Fax 630-859-0971

ROD END NO.		DIMENSIONS IN INCHES								a° Misalign. Angle	Ultimate Radial Static Load Capacity Lbs.	Approx. Brg. Wt. Lbs.
Right Hand	Left Hand	B +.0015 -.0005	W +.000 -.005	H ±.005	A ±.015	D ±.010	Ball Dia. Ref.	C +.062 -.031	Thread UNF-3A			
XM-3	XB-3	.1900	.312	.250	1.562	.750	.437	1.000	1/4-28	10	2,158	.04
XM-4	XB-4	.2500	.375	.281	1.875	.875	.500	1.250	5/16-24	13	3,467	.07
XM-5	XB-5	.3125	.437	.344	1.938	1.000	.625	1.250	3/8-24	12	5,323	.11
XM-6	XB-6	.3750	.500	.406	2.125	1.125	.719	1.375	7/16-20	10	7,180	.16
XM-7	XB-7	.4375	.562	.437	2.438	1.312	.812	1.500	1/2-20	12	9,620	.25
XM-8	XB-8	.5000	.625	.500	2.625	1.500	.937	1.625	5/8-18	10	12,807	.38
XM-10	XB-10	.6250	.750	.562	2.875	1.750	1.125	1.750	3/4-16	13	16,565	.60
XM-12	XB-12	.7500	.875	.687	3.375	2.000	1.312	1.875	7/8-14	12	22,803	.92
XM-12-1	XB-12-1	.7500	.875	.687	3.375	2.000	1.312	1.875	3/4-16	12	22,803	.92
XM-14-1	XB-14-1	.8750	.875	.687	3.375	2.000	1.312	1.875	7/8-14	12	22,803	.92

ROD END NO.		DIMENSIONS IN MILLIMETERS								a° Misalign. Angle	Ultimate Radial Static Load Capacity Newtons	Approx. Brg. Wt. Grams
Right Hand	Left Hand	B +.038 -.013	W +.00 -.13	H ±.13	A ±.38	D ±.25	Ball Dia. Ref.	C + 1.57 -.79	Thread UNF-3A			
XM-3	XB-3	4.826	7.92	6.35	39.67	19.05	11.10	25.40	1/4-28	10	9,600	20
XM-4	XB-4	6.350	9.53	7.14	47.63	22.23	12.70	31.75	5/16-24	13	15,425	33
XM-5	XB-5	7.938	11.10	8.74	49.23	25.40	15.88	31.75	3/8-24	12	23,682	51
XM-6	XB-6	9.525	12.70	10.31	53.98	28.58	18.26	34.93	7/16-20	10	31,938	73
XM-7	XB-7	11.113	14.27	11.10	61.93	33.32	20.62	38.10	1/2-20	12	42,794	113
XM-8	XB-8	12.700	15.88	12.70	66.68	38.10	23.80	41.28	5/8-18	10	56,963	173
XM-10	XB-10	15.875	19.05	14.27	73.02	44.45	28.58	44.45	3/4-16	13	73,683	273
XM-12	XB-12	19.050	22.23	17.45	85.73	50.80	33.32	47.63	7/8-14	12	101,424	427
XM-12-1	XB-12-1	19.050	22.23	17.45	85.73	50.80	33.32	47.63	3/4-16	12	101,424	427
XM-14-1	XB-14-1	22.225	22.23	17.45	85.73	50.80	33.32	47.63	7/8-14	12	101,424	427

Studs available per notes and comments, page 76



# KM & KB SERIES MALE ROD ENDS

General Purpose - Precision - Wear Resistant

**Body** - Low carbon steel, protective coated for corrosion resistance. No. 16 series standard body is alloy steel not heat treated.

**Race** - Alloy steel, heat treated, protective coated for corrosion resistance.

**Ball** - Alloy steel, heat treated, hard chrome plated.

**Notes** - All sizes available with studs upon request.

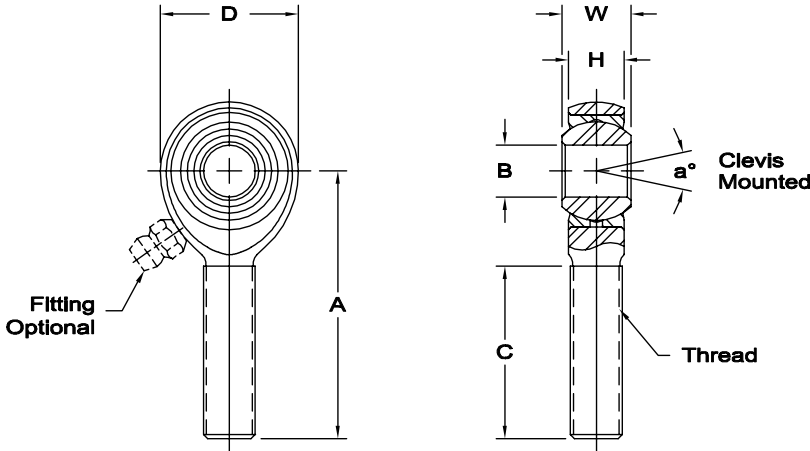

\* Check for availability.

- 1 Tolerance variation: "D"  $\pm .020$ , "A"  $\pm .020$ , "B"  $+ .0035$ ,  $- .0005$ , "H"  $\pm .010$
- 2 Tolerance variation: "D"  $\pm .51$ , "A"  $\pm .51$ , "B"  $+ .089$ ,  $- .013$ , "H"  $\pm .25$
- 3 Threads 1-14 UNS.

Units are supplied without grease fittings. When a grease fitting is required, specify by adding suffix as designated.

- Z Zerk type fitting Ex: KM-6Z
- F Flush type fitting Ex: KM-6F

Load ratings apply only to rod ends without grease fittings. For load ratings with fittings, please consult our engineering department.

ROD END NO.		DIMENSIONS IN INCHES								a° Misalign. Angle	Ultimate Radial Static Load Capacity Lbs.	Approx. Brg. Wt. Lbs.
Right Hand	Left Hand	B + .0015 - .0005	W + .000 - .005	H $\pm .005$	A $\pm .015$	D $\pm .010$	Ball Dia. Ref.	C + .062 - .031	Thread UNF-3A			
KM-3	KB-3	.1900	.312	.250	1.250	.625	.437	.750	10-32	13	1,169	.03
KM-4	KB-4	.2500	.375	.281	1.562	.750	.500	1.000	1/4-28	16	2,158	.04
KM-5	KB-5	.3125	.437	.344	1.875	.875	.625	1.250	5/16-24	14	2,784	.07
KM-6	KB-6	.3750	.500	.406	1.938	1.000	.719	1.250	3/8-24	12	3,915	.11
KM-7	KB-7	.4375	.562	.437	2.125	1.125	.812	1.375	7/16-20	14	4,218	.16
KM-8	KB-8	.5000	.625	.500	2.438	1.312	.937	1.500	1/2-20	12	6,660	.25
KM-10	KB-10	.6250	.750	.562	2.625	1.500	1.125	1.625	5/8-18	16	7,364	.38
KM-12	KB-12	.7500	.875	.687	2.875	1.750	1.312	1.750	3/4-16	14	11,518	.60
* KM-14	KB-14	.8750	.875	.765	3.375	2.000	1.375	2.000	7/8-14	7	18,476	.91
1 KM-16	KB-16	1.0000	1.375	1.000	4.125	2.750	1.875	2.125	1 1/4-12	17	43,541	2.41
1 KM-16-1	KB-16-1	1.0000	1.375	1.000	4.125	2.750	1.875	2.125	1-14 <sub>3</sub>	17	43,541	2.13
1 KM-16-2	KB-16-2	1.0000	1.375	1.000	4.125	2.750	1.875	2.125	1-12	17	43,541	2.13

ROD END NO.		DIMENSIONS IN MILLIMETERS								a° Misalign. Angle	Ultimate Radial Static Load Capacity Newtons	Approx. Brg. Wt. Grams
Right Hand	Left Hand	B + .038 - .013	W + .00 - .13	H $\pm .13$	A $\pm .38$	D $\pm .25$	Ball Dia. Ref.	C + 1.57 - .79	Thread UNF-3A			
KM-3	KB-3	4.826	7.92	6.35	31.75	15.88	11.10	19.05	10-32	13	5,197	13
KM-4	KB-4	6.350	9.53	7.14	39.67	19.05	12.70	25.40	1/4-28	16	9,600	20
KM-5	KB-5	7.938	11.10	8.74	47.63	22.23	15.88	31.75	5/16-24	14	12,385	33
KM-6	KB-6	9.525	12.70	10.31	49.23	25.40	18.26	31.75	3/8-24	12	17,416	51
KM-7	KB-7	11.113	14.27	11.10	53.98	28.58	20.62	34.93	7/16-20	14	18,759	73
KM-8	KB-8	12.700	15.88	12.70	61.93	33.32	23.80	38.10	1/2-20	12	29,624	113
KM-10	KB-10	15.875	19.05	14.27	66.68	38.10	28.58	41.28	5/8-18	16	32,752	173
KM-12	KB-12	19.050	22.23	17.45	73.03	44.45	33.32	44.45	3/4-16	14	51,237	273
* KM-14	KB-14	22.225	22.23	19.43	85.73	50.80	34.93	50.80	7/8-14	7	82,185	411
2 KM-16	KB-16	25.400	34.93	25.40	104.78	69.85	47.63	53.98	1 1/4-12	17	193,670	1,091
2 KM-16-1	KB-16-1	25.400	34.93	25.40	104.78	69.85	47.63	53.98	1-14 <sub>3</sub>	17	193,670	965
2 KM-16-2	KB-16-2	25.400	34.93	25.40	104.78	69.85	47.63	53.98	1-12	17	193,670	965

timkenaurorabearing.com • Fax 630-859-0971

# KW & KG SERIES FEMALE ROD ENDS

General Purpose - Precision - Wear Resistant



**Body** - Low carbon steel, protective coated for corrosion resistance. No. 16 series standard body is alloy steel not heat treated.

**Race** - Alloy steel, heat treated, protective coated for corrosion resistance.

**Ball** - Alloy steel, heat treated, hard chrome plated.

**Notes** - All sizes available with studs upon request.

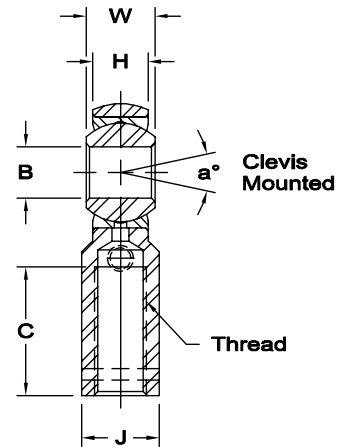
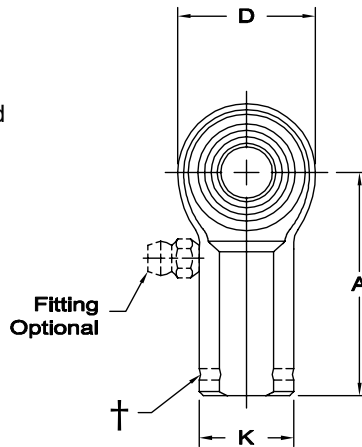

\* Check for availability

† Left hand units have identification groove near end of shank.

1 Tolerance variation: "D" ± .020, "A" ± .020 "B" + .0035, - .0005, "H" ± .010, "K" ± .015, "J" ± .015

2 Tolerance variation: "D" ± .51, "A" ± .51 "B" + .089, -.013, "H" ± .25, "K" ± .38, "J" ± .38

3 Threads 1-14 UNS

Units are supplied without grease fittings. When a grease fitting is required, specify by adding suffix as designated.

Z Zerk type fitting  
F Flush type fitting

Ex: KW-6Z  
Ex: KW-6F

ROD END NO.		DIMENSIONS IN INCHES										a°	Ultimate Radial	Approx.
Right Hand	Left Hand†	B + .0015 - .0005	W + .000 - .005	H ± .005	A ± .015	D ± .010	K ± .010	J ± .010	Ball Dia. Ref.	C + .062 - .031	Thread UNF-2B	Misalign. Angle	Static Load Capacity Lbs.	Brg. Wt. Lbs.
KW-3	KG-3	.1900	.312	.250	1.062	.625	.406	.312	.437	.562	10-32	13	1,531	.04
KW-4	KG-4	.2500	.375	.281	1.312	.750	.469	.375	.500	.750	1/4-28	16	2,539	.06
KW-5	KG-5	.3125	.437	.344	1.375	.875	.500	.437	.625	.750	5/16-24	14	3,133	.09
KW-6	KG-6	.3750	.500	.406	1.625	1.000	.687	.562	.719	.937	3/8-24	12	3,915	.15
KW-7	KG-7	.4375	.562	.437	1.812	1.125	.750	.625	.812	1.062	7/16-20	14	4,218	.20
KW-8	KG-8	.5000	.625	.500	2.125	1.312	.875	.750	.937	1.187	1/2-20	12	6,660	.33
KW-10	KG-10	.6250	.750	.562	2.500	1.500	1.000	.875	1.125	1.500	5/8-18	16	7,364	.48
KW-12	KG-12	.7500	.875	.687	2.875	1.750	1.125	1.000	1.312	1.750	3/4-16	14	11,518	.72
* KW-14	KG-14	.8750	.875	.765	3.375	2.000	1.300	1.125	1.375	1.875	7/8-14	7	18,476	1.03
1 KW-16	KG-16	1.0000	1.375	1.000	4.125	2.750	1.625	1.500	1.875	2.125	1 1/4-12	17	40,889	2.13
1 KW-16-1	KG-16-1	1.0000	1.375	1.000	4.125	2.750	1.625	1.500	1.875	2.125	1-14 <sub>3</sub>	17	43,541	2.41
1 KW-16-2	KG-16-2	1.0000	1.375	1.000	4.125	2.750	1.625	1.500	1.875	2.125	1-12	17	43,541	2.41

ROD END NO.		DIMENSIONS IN MILLIMETERS										a°	Ultimate Radial	Approx.
Right Hand	Left Hand†	B + .038 - .013	W + .00 - .13	H ± .13	A ± .38	D ± .25	K ± .25	J ± .25	Ball Dia. Ref.	C + 1.57 - .79	Thread UNF-2B	Misalign. Angle	Static Load Capacity Newtons	Brg. Wt. Grams
KW-3	KG-3	4.826	7.92	6.35	26.97	15.88	10.31	7.92	11.10	14.27	10-32	13	6,805	17
KW-4	KG-4	6.350	9.53	7.14	33.32	19.05	11.91	9.53	12.70	19.05	1/4-28	16	11,297	27
KW-5	KG-5	7.938	11.10	8.74	34.93	22.23	12.70	11.10	15.88	19.05	5/16-24	14	13,934	42
KW-6	KG-6	9.525	12.70	10.31	41.28	25.40	17.45	14.27	18.26	23.80	3/8-24	12	17,416	69
KW-7	KG-7	11.113	14.27	11.10	46.02	28.58	19.05	15.88	20.62	26.97	7/16-20	14	18,759	90
KW-8	KG-8	12.700	15.88	12.70	53.98	33.32	22.23	19.05	23.80	30.15	1/2-20	12	29,624	149
KW-10	KG-10	15.875	19.05	14.27	63.50	38.10	25.40	22.23	28.58	38.10	5/8-18	16	32,752	216
KW-12	KG-12	19.050	22.23	17.45	73.03	44.45	28.58	25.40	33.32	44.45	3/4-16	14	51,237	328
* KW-14	KG-14	22.225	22.23	19.43	85.73	50.80	33.02	28.58	34.93	47.63	7/8-14	7	82,185	467
2 KW-16	KG-16	25.400	34.93	25.40	104.78	69.85	41.28	38.10	47.63	53.98	1 1/4-12	17	181,874	964
2 KW-16-1	KG-16-1	25.400	34.93	25.40	104.78	69.85	41.28	38.10	47.63	53.98	1-14 <sub>3</sub>	17	193,670	1,093
2 KW-16-2	KG-16-2	25.400	34.93	25.40	104.78	69.85	41.28	38.10	47.63	53.98	1-12	17	193,670	1,093



# SM & SB SERIES MALE ROD ENDS

Corrosion Resistant – Precision (PTFE Liners Available)

timkenaurorabearing.com • Fax 630-859-0971

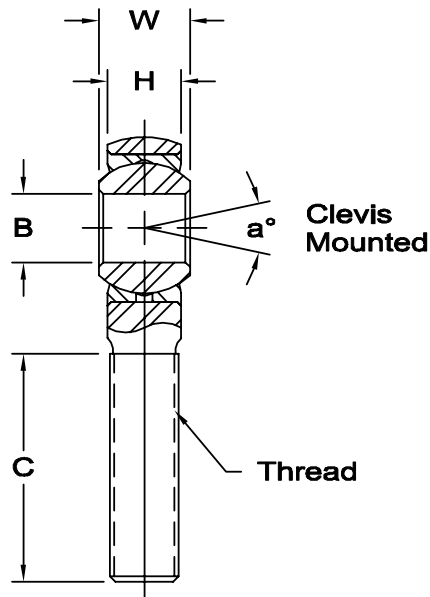
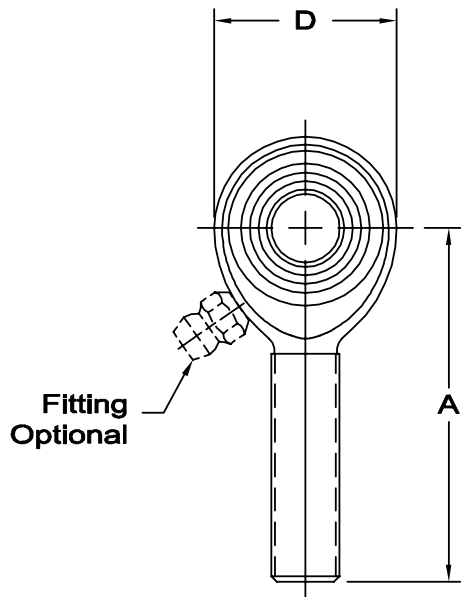

**Body** - Low carbon steel, Electroless nickel plated.

**Race** - Stainless steel, heat treated.

**Ball** - Alloy steel, heat treated, hard chrome plated.

**Notes** - All sizes available with studs upon request.

Load ratings apply only to rod ends without grease fittings. For load ratings with fittings, please consult our engineering department.

Units are supplied without grease fittings. When a grease fitting is required, specify by adding suffix as designated.

- Z Zerk type fitting Ex: SM-6Z
- F Flush type fitting Ex: SM-6F
- T PTFE liner Ex: SM-6T

ROD END NO.		DIMENSIONS IN INCHES								a° Misalign. Angle	Ultimate Radial Static Load Capacity Lbs.	Approx. Brg. Wt. Lbs.
Right Hand	Left Hand	B + .0015 - .0005	W + .000 - .005	H ± .005	A ± .015	D ± .010	Ball Dia. Ref.	C + .062 - .031	Thread UNF-3A			
SM-3	SB-3	.1900	.312	.250	1.250	.625	.437	.750	10-32	13	1,169	.03
SM-4	SB-4	.2500	.375	.281	1.562	.750	.500	1.000	1/4-28	16	2,158	.04
SM-5	SB-5	.3125	.437	.344	1.875	.875	.625	1.250	5/16-24	14	2,784	.07
SM-6	SB-6	.3750	.500	.406	1.938	1.000	.719	1.250	3/8-24	12	3,915	.11
SM-7	SB-7	.4375	.562	.437	2.125	1.125	.812	1.375	7/16-20	14	4,218	.16
SM-8	SB-8	.5000	.625	.500	2.438	1.312	.937	1.500	1/2-20	12	6,660	.25
SM-10	SB-10	.6250	.750	.562	2.625	1.500	1.125	1.625	5/8-18	16	7,364	.38
SM-12	SB-12	.7500	.875	.687	2.875	1.750	1.312	1.750	3/4-16	14	11,518	.60

ROD END NO.		DIMENSIONS IN MILLIMETERS								a° Misalign. Angle	Ultimate Radial Static Load Capacity Newtons	Approx. Brg. Wt. Grams
Right Hand	Left Hand	B + .038 - .013	W + .00 - .13	H ± .13	A + .38	D ± .25	Ball Dia. Ref.	C + 1.57 - .79	Thread UNF-3A			
SM-3	SB-3	4.826	7.92	6.35	31.75	15.88	11.10	19.05	10-32	13	5,197	13
SM-4	SB-4	6.350	9.53	7.14	39.67	19.05	12.70	25.40	1/4-28	16	9,600	20
SM-5	SB-5	7.938	11.10	8.74	47.63	22.23	15.88	31.75	5/16-24	14	12,385	33
SM-6	SB-6	9.525	12.70	10.31	49.23	25.40	18.26	31.75	3/8-24	12	17,416	51
SM-7	SB-7	11.113	14.27	11.10	53.98	28.58	20.62	34.93	7/16-20	14	18,759	73
SM-8	SB-8	12.700	15.88	12.70	61.93	33.32	23.80	38.10	1/2-20	12	29,624	113
SM-10	SB-10	15.875	19.05	14.27	66.68	38.10	28.58	41.28	5/8-18	16	32,752	173
SM-12	SB-12	19.050	22.23	17.45	73.03	44.45	33.32	44.45	3/4-16	14	51,237	273

# SW & SG SERIES FEMALE ROD ENDS

Corrosion Resistant – Precision (PTFE Liners Available)



**Body** - Low carbon steel, Electroless nickel plated.

**Race** - Stainless steel, heat treated.

**Ball** - Alloy steel, heat treated, hard chrome plated.

**Notes** - All sizes available with studs upon request.

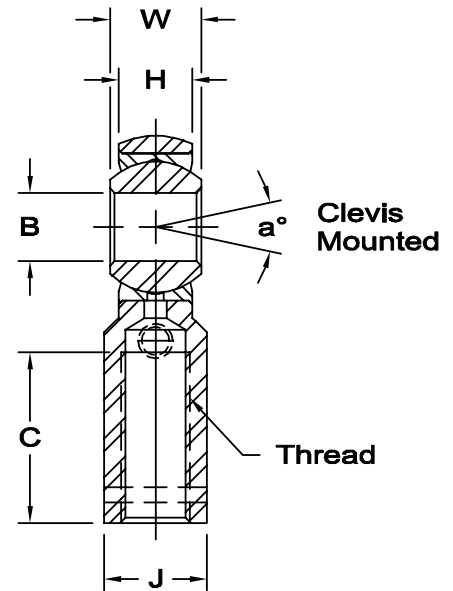
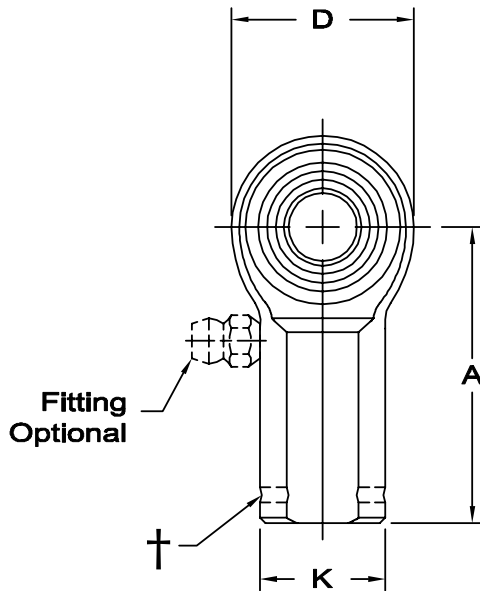

† Left hand units have identification groove near end of shank.

Units are supplied without grease fittings. When a grease fitting is required, specify by adding suffix as designated.

- Z Zerk type fitting Ex: SW-6Z
- F Flush type fitting Ex: SW-6F
- T PTFE liner Ex: SW-6T

ROD END NO.		DIMENSIONS IN INCHES										a° Misalign. Angle	Ultimate Radial Static Load Capacity Lbs.	Approx. Brg. Wt. Lbs.
Right Hand	Left Hand†	B +.0015 -.0005	W +.000 -.005	H ±.005	A ±.015	D ±.010	K ±.010	J ±.010	Ball Dia. Ref.	C +.062 -.031	Thread UNF-2B			
SW-3	SG-3	.1900	.312	.250	1.062	.625	.406	.312	.437	.562	10-32	13	1,531	.04
SW-4	SG-4	.2500	.375	.281	1.312	.750	.469	.375	.500	.750	1/4-28	16	2,539	.06
SW-5	SG-5	.3125	.437	.344	1.375	.875	.500	.437	.625	.750	5/16-24	14	3,133	.09
SW-6	SG-6	.3750	.500	.406	1.625	1.000	.687	.562	.719	.937	3/8-24	12	3,915	.15
SW-7	SG-7	.4375	.562	.437	1.812	1.125	.750	.625	.812	1.062	7/16-20	14	4,218	.20
SW-8	SG-8	.5000	.625	.500	2.125	1.312	.875	.750	.937	1.187	1/2-20	12	6,660	.33
SW-10	SG-10	.6250	.750	.562	2.500	1.500	1.000	.875	1.125	1.500	5/8-18	16	7,364	.48
SW-12	SG-12	.7500	.875	.687	2.875	1.750	1.125	1.000	1.312	1.750	3/4-16	14	11,518	.72

ROD END NO.		DIMENSIONS IN MILLIMETERS										a° Misalign. Angle	Ultimate Radial Static Load Capacity Newtons	Approx. Brg. Wt. Grams
Right Hand	Left Hand†	B +.038 -.013	W +.00 -.13	H ±.13	A ±.38	D ±.25	K ±.25	J ±.25	Ball Dia. Ref.	C + 1.57 -.79	Thread UNF-2B			
SW-3	SG-3	4.826	7.92	6.35	26.97	15.88	10.31	7.92	11.10	14.27	10-32	13	6,805	17
SW-4	SG-4	6.350	9.53	7.14	33.32	19.05	11.91	9.53	12.70	19.05	1/4-28	16	11,297	27
SW-5	SG-5	7.938	11.10	8.74	34.93	22.23	12.70	11.10	15.88	19.05	5/16-24	14	13,934	42
SW-6	SG-6	9.525	12.70	10.31	41.28	25.40	17.45	14.27	18.26	23.80	3/8-24	12	17,416	69
SW-7	SG-7	11.113	14.27	11.10	46.02	28.58	19.05	15.88	20.62	26.97	7/16-20	14	18,759	90
SW-8	SG-8	12.700	15.88	12.70	53.98	33.32	22.23	19.05	23.80	30.15	1/2-20	12	29,624	149
SW-10	SG-10	15.875	19.05	14.27	63.50	38.10	25.40	22.23	28.58	38.10	5/8-18	16	32,752	216
SW-12	SG-12	19.050	22.23	17.45	73.03	44.45	28.58	25.40	33.32	44.45	3/4-16	14	51,237	328



# CM-ET & CB-ET SERIES STAINLESS STEEL MALE ROD ENDS

Corrosion Resistant – Self Lubricating

timkenaurorabearing.com • Fax 630-859-0971

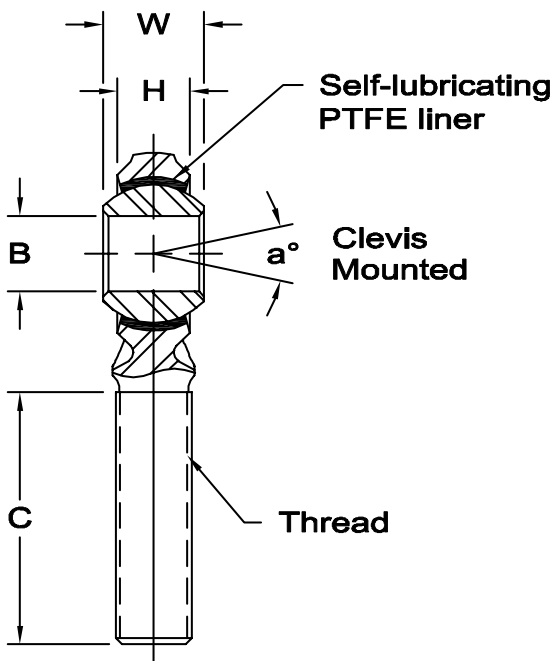
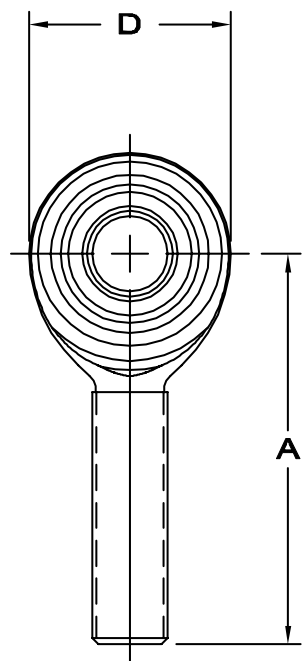

**Body** - 17-4 PH stainless steel, heat treated.

**Ball** - 440 C stainless steel, heat treated, hard chrome plated. (MFG. Option).

**Bushing** - 17-4 PH stainless steel, heat treated, PTFE lined.

**Notes** - All sizes available with studs upon request.

(1) Manufacturer's Option: -2A

ROD END NO.		DIMENSIONS IN INCHES								a° Misalign. Angle	Ultimate Radial Static Load Capacity Lbs.	Approx. Brg. Wt. Lbs.
Right Hand	Left Hand	B + .0015 - .0005	W + .000 - .005	H Ref.	A ± .015	D Ref.	Ball Dia. Ref.	C + .062 - .031	Thread UNF-3A (1)			
CM-5ET	CB-5ET	.3125	.437	.312	1.875	.875	.593	1.250	5/16-24	18	6,451	.07
CM-6ET	CB-6ET	.3750	.500	.359	1.938	1.000	.687	1.250	3/8-24	18	8,627	.11
CM-7ET	CB-7ET	.4375	.562	.406	2.125	1.125	.781	1.375	7/16-20	17	9,370	.15
CM-8ET	CB-8ET	.5000	.625	.453	2.438	1.312	.875	1.500	1/2-20	16	15,130	.24
CM-10ET	CB-10ET	.6250	.750	.484	2.625	1.500	1.062	1.625	5/8-18	22	16,922	.36
CM-12ET	CB-12ET	.7500	.875	.593	2.875	1.750	1.250	1.750	3/4-16	20	25,549	.57

ROD END NO.		DIMENSIONS IN MILLIMETERS								a° Misalign. Angle	Ultimate Radial Static Load Capacity Newtons	Approx. Brg. Wt. Grams
Right Hand	Left Hand	B + .038 - .013	W + .00 - .13	H Ref.	A + .38	D Ref.	Ball Dia. Ref.	C + 1.57 - .79	Thread UNF-3A (1)			
CM-5ET	CB-5ET	7.938	11.10	7.92	47.63	22.23	15.06	31.75	5/16-24	18	28,693	32
CM-6ET	CB-6ET	9.525	12.70	9.12	49.23	25.40	17.45	31.75	3/8-24	18	38,371	50
CM-7ET	CB-7ET	11.113	14.27	10.31	53.98	28.58	19.84	34.93	7/16-20	17	41,676	68
CM-8ET	CB-8ET	12.700	15.88	11.50	61.93	33.32	22.23	38.10	1/2-20	16	67,299	109
CM-10ET	CB-10ET	15.875	19.05	12.29	66.68	38.10	26.97	41.28	5/8-18	22	75,271	163
CM-12ET	CB-12ET	19.050	22.23	15.06	73.03	44.45	31.75	44.45	3/4-16	20	113,642	259



# CW-ET & CG-ET SERIES STAINLESS STEEL FEMALE ROD ENDS

Corrosion Resistant – Self Lubricating



**Body** - 17-4 PH stainless steel, heat treated.

**Ball** - 440 C stainless steel, heat treated, hard chrome plated. (MFG. Option).

**Bushing** - 17-4 PH stainless steel, heat treated, PTFE lined.

**Notes** - All sizes available with studs upon request.

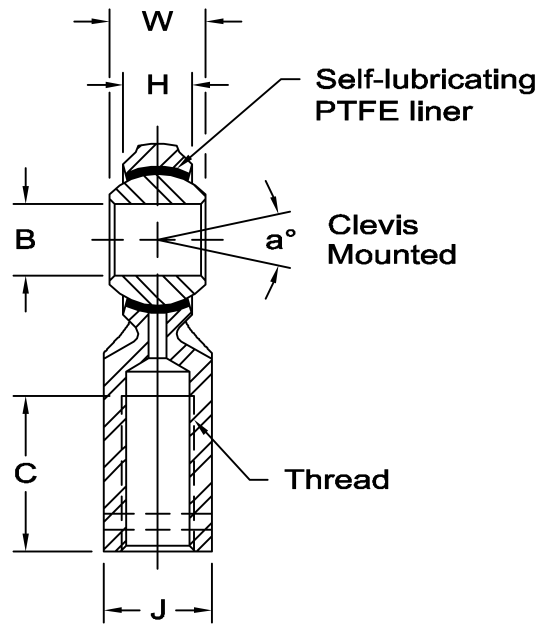
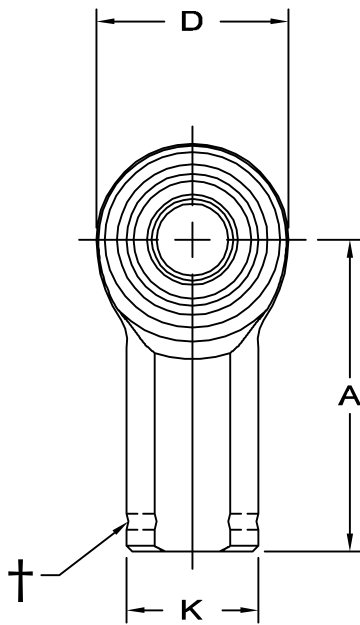

timkenaurorabearing.com • Fax 630-859-0971

† Left hand units have identification groove near end of shank

ROD END NO.		DIMENSIONS IN INCHES										a° Misalign. Angle	Ultimate Radial Static Load Capacity Lbs.	Approx. Brg. Wt. Lbs.
Right Hand	Left Hand†	B +.0015 -.0005	W +.000 -.005	H Ref.	A ±.015	D Ref.	K ±.010	J ±.010	Ball Dia. Ref.	C +.062 -.031	Thread UNF-2B			
CW-5ET	CG-5ET	.3125	.437	.312	1.375	.875	.500	.437	.593	.687	5/16-24	18	6,451	.08
CW-6ET	CG-6ET	.3750	.500	.359	1.625	1.000	.687	.562	.687	.812	3/8-24	18	8,627	.13
CW-7ET	CG-7ET	.4375	.562	.406	1.812	1.125	.750	.625	.781	.937	7/16-20	17	9,370	.18
CW-8ET	CG-8ET	.5000	.625	.453	2.125	1.312	.875	.750	.875	1.062	1/2-20	16	15,130	.29
CW-10ET	CG-10ET	.6250	.750	.484	2.500	1.500	1.000	.875	1.062	1.375	5/8-18	22	16,922	.43
CW-12ET	CG-12ET	.7500	.875	.593	2.875	1.750	1.125	1.000	1.250	1.562	3/4-16	20	25,549	.65

ROD END NO.		DIMENSIONS IN MILLIMETERS										a° Misalign. Angle	Ultimate Radial Static Load Capacity Newtons	Approx. Brg. Wt. Grams
Right Hand	Left Hand †	B +.038 -.013	W +.00 -.13	H Ref.	A ±.38	D Ref.	K ±.25	J ±.25	Ball Dia. Ref.	C + 1.57 -.79	Thread UNF-2B			
CW-5ET	CG-5ET	7.938	11.10	7.92	34.93	22.23	12.70	11.10	15.06	17.45	5/16-24	18	28,693	36
CW-6ET	CG-6ET	9.525	12.70	9.12	41.28	25.40	17.45	14.27	17.45	20.62	3/8-24	18	38,371	59
CW-7ET	CG-7ET	11.113	14.27	10.31	46.02	28.58	19.05	15.88	19.84	23.80	7/16-20	17	41,676	82
CW-8ET	CG-8ET	12.700	15.88	11.50	53.98	33.32	22.23	19.05	22.23	26.97	1/2-20	16	67,299	132
CW-10ET	CG-10ET	15.875	19.05	12.29	63.50	38.10	25.40	22.23	26.97	34.93	5/8-18	22	75,271	195
CW-12ET	CG-12ET	19.050	22.23	15.06	73.03	44.45	28.58	25.40	31.75	39.67	3/4-16	20	113,642	295



# SM-E & SB-E SERIES STAINLESS STEEL MALE ROD ENDS

Corrosion Resistant – Precision (PTFE Liners Available)

timkenaurorabearing.com • Fax 630-859-0971

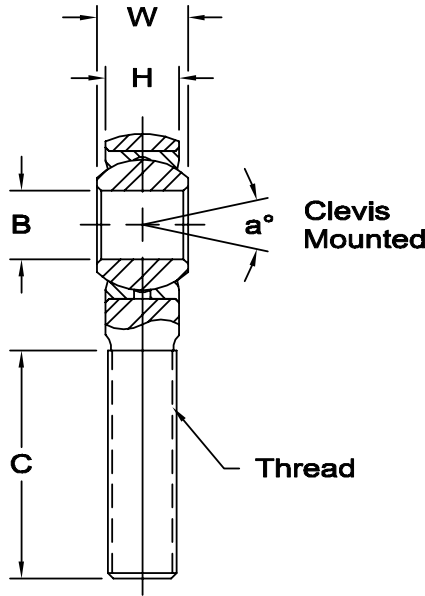
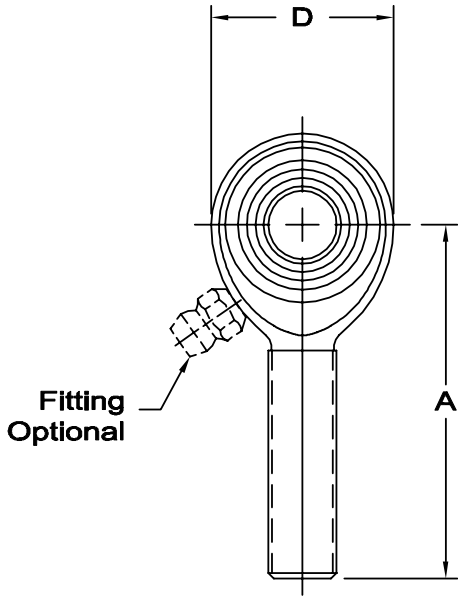

**Body** - 17-4 PH stainless steel, heat treated.

**Race** - 17-4 PH stainless steel, heat treated.

**Ball** - 440 C stainless steel, heat treated, hard chrome plated. (MFG. Option).

**Notes** - All sizes available with studs upon request.

- 1 Tolerance variation: "D" ± .020, "A" ± .020, "H" ± .010
- 2 Tolerance variation: "D" ± .51, "A" ± .51, "H" ± .25

Units are supplied without grease fittings. When a grease fitting is required, specify by adding suffix as designated.

- Z Zerk type fitting                      Ex: SM-6EZ
- F Flush type fitting                      Ex: SM-6EF
- T PTFE liner                                Ex: SM-6ET

Load ratings apply only to rod ends without grease fittings. For load ratings with fittings, please consult our engineering department.

ROD END NO.		DIMENSIONS IN INCHES								a° Misalign. Angle	Ultimate Radial Static Load Capacity Lbs.	Approx. Brg. Wt. Lbs.
Right Hand	Left Hand	B + .0015 - .0005	W + .000 - .005	H ± .005	A ± .015	D ± .010	Ball Dia. Ref.	C + .062 - .031	Thread UNF-3A			
SM-3E	SB-3E	.1900	.312	.250	1.250	.625	.437	.750	10-32	13	2,199	.03
SM-4E	SB-4E	.2500	.375	.281	1.562	.750	.500	1.000	1/4-28	16	4,058	.04
SM-5E	SB-5E	.3125	.437	.344	1.875	.875	.625	1.250	5/16-24	14	5,929	.07
SM-6E	SB-6E	.3750	.500	.406	1.938	1.000	.719	1.250	3/8-24	12	7,363	.11
SM-7E	SB-7E	.4375	.562	.437	2.125	1.125	.812	1.375	7/16-20	14	7,934	.16
SM-8E	SB-8E	.5000	.625	.500	2.438	1.312	.937	1.500	1/2-20	12	12,527	.25
SM-10E	SB-10E	.6250	.750	.562	2.625	1.500	1.125	1.625	5/8-18	16	13,851	.38
SM-12E	SB-12E	.7500	.875	.687	2.875	1.750	1.312	1.750	3/4-16	14	21,664	.60
1 SM-16E	SB-16E	1.0000	1.375	1.000	4.125	2.750	1.875	2.125	1 1/4-12	17	72,947	2.41

ROD END NO.		DIMENSIONS IN MILLIMETERS								a° Misalign. Angle	Ultimate Radial Static Load Capacity Newtons	Approx. Brg. Wt. Grams
Right Hand	Left Hand	B + .038 - .013	W + .00 - .13	H ± .13	A ± .38	D ± .25	Ball Dia. Ref.	C + 1.57 - .79	Thread UNF-3A			
SM-3E	SB-3E	4.826	7.92	6.35	31.75	15.88	11.10	19.05	10-32	13	9,781	13
SM-4E	SB-4E	6.350	9.53	7.14	39.67	19.05	12.70	25.40	1/4-28	16	18,050	20
SM-5E	SB-5E	7.938	11.10	8.74	47.63	22.23	15.88	31.75	5/16-24	14	26,372	33
SM-6E	SB-6E	9.525	12.70	10.31	49.23	25.40	18.26	31.75	3/8-24	12	32,751	51
SM-7E	SB-7E	11.113	14.27	11.10	53.98	28.58	20.62	34.93	7/16-20	14	35,290	73
SM-8E	SB-8E	12.700	15.88	12.70	61.93	33.32	23.80	38.10	1/2-20	12	55,720	113
SM-10E	SB-10E	15.875	19.05	14.27	66.68	38.10	28.58	41.28	5/8-18	16	61,609	173
SM-12E	SB-12E	19.050	22.23	17.45	73.03	44.45	33.32	44.45	3/4-16	14	96,361	273
2 SM-16E	SB-16E	25.400	34.93	25.40	104.78	69.85	47.63	53.98	1 1/4-12	17	324,468	1,091

# SW-E & SG-E SERIES STAINLESS STEEL FEMALE ROD ENDS

Corrosion Resistant – Precision (PTFE Liners Available)



**Body** - 17-4 PH stainless steel, heat treated.

**Race** - 17-4 PH stainless steel, heat treated.

**Ball** - 440 C stainless steel, heat treated, hard chrome plated. (MFG. Option).

**Notes** - All sizes available with studs upon request.

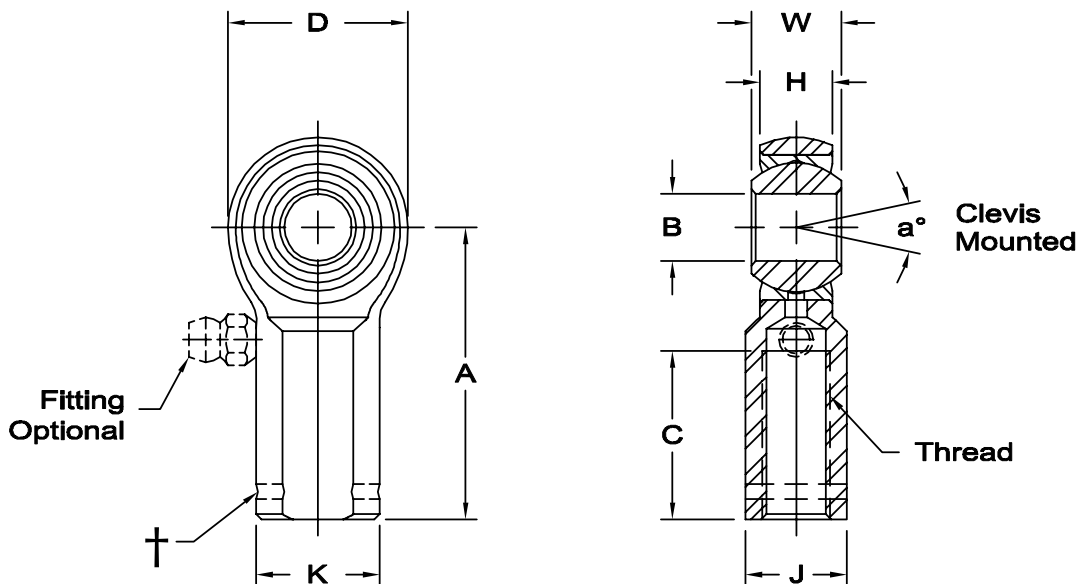

- † Left hand units have identification groove near end of shank
- 1 Tolerance variation: "D" ± .020, "A" ± .020, "H" ± .010, "J" ± .015, "K" ± .015
- 2 Tolerance variation: "D" ± .51, "A" ± .51, "H" ± .25, "J" ± .38, "K" ± .38
- 3 Notes 1 and 2 both have UNF-2B threads.

Units are supplied without grease fittings. When a grease fitting is required, specify by adding suffix as designated.

- Z Zerk type fitting Ex: SW-6EZ
- F Flush type fitting Ex: SW-6EF
- T PTFE liner Ex: SW-6ET

ROD END NO.		DIMENSIONS IN INCHES										a° Misalign. Angle	Ultimate Radial Static Load Capacity Lbs.	Approx. Brg. Wt. Lbs.
Right Hand	Left Hand†	B + .0015 - .0005	W + .000 - .005	H ± .005	A ± .015	D ± .010	K ± .010	J ± .010	Ball Dia. Ref.	C + .062 - .031	Thread UNF-3B			
SW-3E	SG-3E	.1900	.312	.250	1.062	.625	.406	.312	.437	.562	10-32	13	2,895	.04
SW-4E	SG-4E	.2500	.375	.281	1.312	.750	.469	.375	.500	.750	1/4-28	16	4,795	.06
SW-5E	SG-5E	.3125	.437	.344	1.375	.875	.500	.437	.625	.750	5/16-24	14	5,929	.09
SW-6E	SG-6E	.3750	.500	.406	1.625	1.000	.687	.562	.719	.937	3/8-24	12	7,363	.15
SW-7E	SG-7E	.4375	.562	.437	1.812	1.125	.750	.625	.812	1.062	7/16-20	14	7,934	.20
SW-8E	SG-8E	.5000	.625	.500	2.125	1.312	.875	.750	.937	1.187	1/2-20	12	12,527	.33
SW-10E	SG-10E	.6250	.750	.562	2.500	1.500	1.000	.875	1.125	1.500	5/8-18	16	13,851	.48
SW-12E	SG-12E	.7500	.875	.687	2.875	1.750	1.125	1.000	1.312	1.750	3/4-16	14	21,664	.72
1 SW-16E	SG-16E	1.0000	1.375	1.000	4.125	2.750	1.625	1.500	1.875	2.125	1 1/4-12	17	61,333	2.13

ROD END NO.		DIMENSIONS IN MILLIMETERS										a° Misalign. Angle	Ultimate Radial Static Load Capacity Newtons	Approx. Brg. Wt. Grams
Right Hand	Left Hand†	B + .038 - .013	W + .00 - .13	H ± .13	A ± .38	D ± .25	K ± .25	J ± .25	Ball Dia. Ref.	C + 1.57 - .79	Thread UNF-3B			
SW-3E	SG-3E	4.826	7.92	6.35	26.97	15.88	10.31	7.92	11.10	14.27	10-32	13	12,877	17
SW-4E	SG-4E	6.350	9.53	7.14	33.32	19.05	11.91	9.53	12.70	19.05	1/4-28	16	21,328	27
SW-5E	SG-5E	7.938	11.10	8.74	34.93	22.23	12.70	11.10	15.88	19.05	5/16-24	14	26,372	42
SW-6E	SG-6E	9.525	12.70	10.31	41.28	25.40	17.45	14.27	18.26	23.80	3/8-24	12	32,751	69
SW-7E	SG-7E	11.113	14.27	11.10	46.02	28.58	19.05	15.88	20.62	26.97	7/16-20	14	35,290	90
SW-8E	SG-8E	12.700	15.88	12.70	53.98	33.32	22.23	19.05	23.80	30.15	1/2-20	12	55,720	149
SW-10E	SG-10E	15.875	19.05	14.27	63.50	38.10	25.40	22.23	28.58	38.10	5/8-18	16	61,609	216
SW-12E	SG-12E	19.050	22.23	17.45	73.03	44.45	28.58	25.40	33.32	44.45	3/4-16	14	96,361	328
2 SW-16E	SG-16E	25.400	34.93	25.40	104.78	69.85	41.28	38.10	47.63	53.98	1 1/4-12	17	272,809	964



# LARGE BORE SERIES MALE ROD ENDS

General Purpose & High Strength – Precision – Wear Resistant (PTFE Liners Available)

## ROD ENDS

1 1/4", 1 1/2" & 2" SIZES

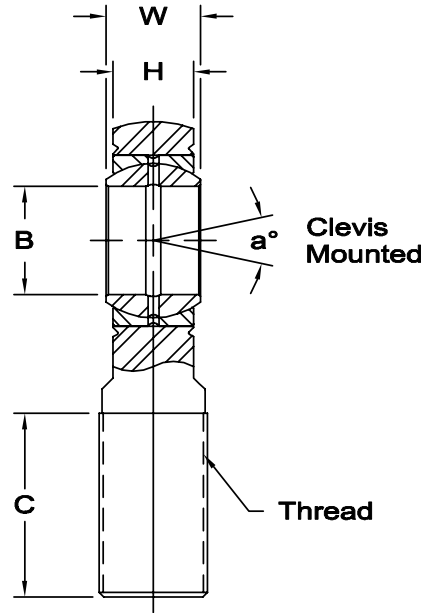
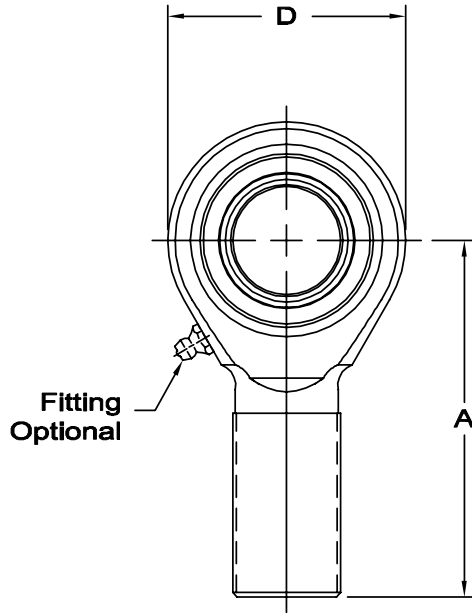

timkenaurorabearing.com • Fax 630-859-0971

**Body (K-Series)** - Alloy steel, protective coated for corrosion resistance.

**Body (A-Series)** - Alloy steel, heat treated, protective coated for corrosion resistance.

**Race** - 52100 steel, heat treated, protective coated for corrosion resistance.

**Ball** - 52100 steel, heat treated, protective coated for corrosion resistance.

1 Tolerance variation: "H" ± .005  
2 Threads 2-12 UN-3A

Units are supplied without grease fittings. When a grease fitting is required, specify by adding suffix as designated.

Z Zerk type fitting Ex: KM-24Z-1  
F Flush type fitting Ex: KM-24F-1  
T PTFE liner Ex: KM-24T-1

### K-SERIES – BODY NON HEAT-TREATED

ROD END NO.		DIMENSIONS IN INCHES								a° Misalign. Angle	Ultimate Radial Static Load Capacity Lbs.	Approx. Brg. Wt. Lbs.
Right Hand	Left Hand	B + .0000 - .0005	W + .000 - .005	H ± .020	A ± .040	D ± .030	Ball Dia. Ref.	C + .062 - .031	Thread UNF-3A			
1 KM-20-1	KB-20-1	1.2500	1.093	.937	4.125	2.750	1.795	2.125	1 1/4-12	7.0	44,500	2.41
1 KM-24-1	KB-24-1	1.5000	1.312	1.125	5.375	3.500	2.155	3.000	1 1/2-12	6.5	64,770	4.75
1 KM-32-1	KB-32-1	2.0000	1.750	1.500	8.000	5.010	2.875	4.500	2-12 <sub>2</sub>	6.0	153,528	14.25

### A-SERIES/XAM-SERIES – BODY HEAT-TREATED

ROD END NO.		DIMENSIONS IN INCHES								a° Misalign. Angle	Ultimate Radial Static Load Capacity Lbs.	Approx. Brg. Wt. Lbs.
Right Hand	Left Hand	B + .0000 - .0005	W + .000 - .005	H ± .020	A ± .040	D ± .030	Ball Dia. Ref.	C + .062 - .031	Thread UNF-3A			
1 AM-20-1	AB-20-1	1.2500	1.093	.937	4.125	2.750	1.795	2.125	1 1/4-12	7.0	79,728	2.41
1 XAM-20-1	XAB-20-1	1.2500	1.093	.937	4.125	2.750	1.795	2.250	1 1/2-12	7.0	79,728	2.63
1 AM-24-1	AB-24-1	1.5000	1.312	1.125	5.375	3.500	2.155	3.000	1 1/2-12	6.5	126,450	4.75
1 XAM-24-1	XAB-24-1	1.5000	1.312	1.125	5.375	3.500	2.155	3.000	1 3/4-12	6.5	126,450	6.06
1 AM-32-1	AB-32-1	2.0000	1.750	1.500	8.000	5.010	2.875	4.500	2-12 <sub>2</sub>	6.0	225,924	14.25

## ROD ENDS

1 1/4", 1 1/2" & 2" SIZES



**Body (K-Series)** - Alloy steel, protective coated for corrosion resistance.

**Body (A-Series)** - Alloy steel, heat treated, protective coated for corrosion resistance.

**Race** - 52100 steel, heat treated, protective coated for corrosion resistance.

**Ball** - 52100 steel, heat treated, protective coated for corrosion resistance.

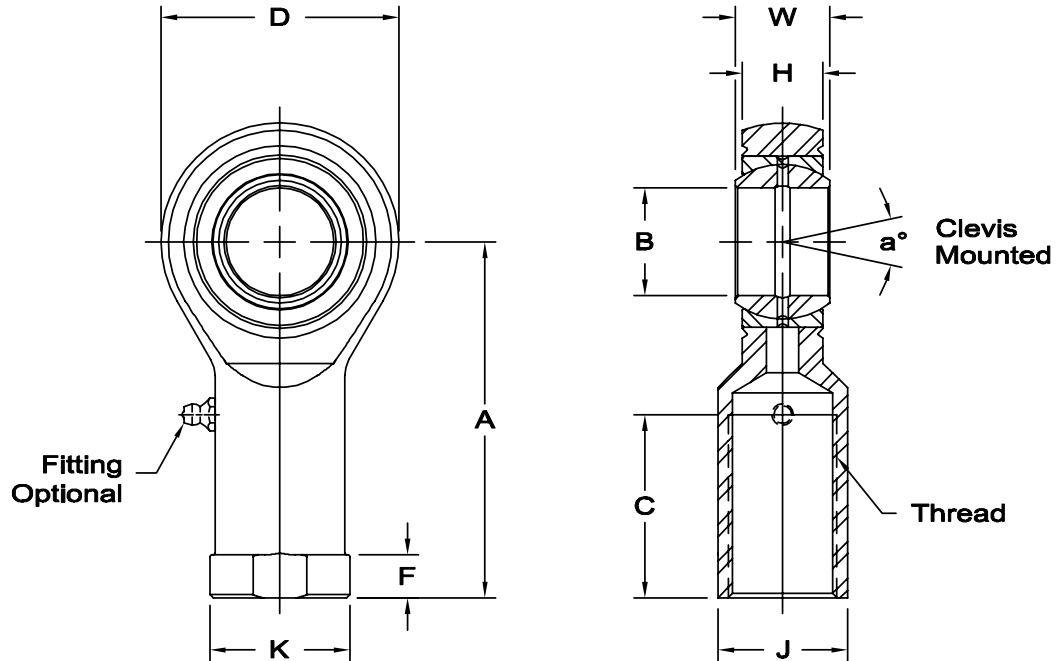

1 Tolerance variation: "H" ± .005, "K" ± .015, "J" ± .015, "F" ± .015  
 2 Threads 2-12 UN-2B

Units are supplied without grease fittings. When a grease fitting is required, specify by adding suffix as designated.

Z Zerk type fitting                      Ex: KW-24Z-1  
 F Flush type fitting                      Ex: KW-24F-1  
 T PTFE liner                                  Ex: KW-24T-1

timkenaurorabearing.com • Fax 630-859-0971

### K-SERIES – BODY NON HEAT-TREATED

ROD END NO.		DIMENSIONS IN INCHES											a° Misalign. Angle	Ultimate Radial Static Load Capacity Lbs.	Approx. Brg. Wt. Lbs.
Right Hand	Left Hand	B +.0000 -.0005	W +.000 -.005	H ±.020	A ±.040	D ±.030	K ±.045	J ±.030	F ±.030	Ball Dia. Ref.	C +.062 -.031	Thread UNF-2B			
1	KW-20-1 / KG-20-1	1.2500	1.093	.937	4.125	2.750	1.625	1.500	.500	1.795	2.125	1 1/4-12	7.0	44,500	2.125
	KW-24-1 / KG-24-1	1.5000	1.312	1.125	5.375	3.500	2.250	2.000	.875	2.155	2.625	1 1/2-12	6.5	64,770	6.50
	KW-32-1 / KG-32-1	2.0000	1.750	1.500	8.000	5.010	3.155	2.750	2.062	2.875	4.000	2-12 <sub>2</sub>	6.0	153,528	15.00

### A-SERIES – BODY HEAT-TREATED

ROD END NO.		DIMENSIONS IN INCHES											a° Misalign. Angle	Ultimate Radial Static Load Capacity Lbs.	Approx. Brg. Wt. Lbs.
Right Hand	Left Hand	B +.0000 -.0005	W +.000 -.005	H ±.020	A ±.040	D ±.030	K ±.045	J ±.030	F ±.030	Ball Dia. Ref.	C +.062 -.031	Thread UNF-2B			
1	AW-20-1 / AG-20-1	1.2500	1.093	.937	4.125	2.750	1.625	1.500	.500	1.795	2.125	1 1/4-12	7.0	79,728	2.13
	AW-24-1 / AG-24-1	1.5000	1.312	1.125	5.375	3.500	2.250	2.000	.875	2.155	2.625	1 1/2-12	6.5	126,450	6.50
	AW-32-1 / AG-32-1	2.0000	1.750	1.500	8.000	5.010	3.155	2.750	2.062	2.875	4.000	2-12 <sub>2</sub>	6.0	225,924	15.00



# LARGE BORE SERIES MALE ROD ENDS

General Purpose & High Strength – Precision – PTFE Lined

## ROD ENDS

1 1/4", 1 1/2" & 2" SIZES

timkenaurorabearing.com • Fax 630-859-0971

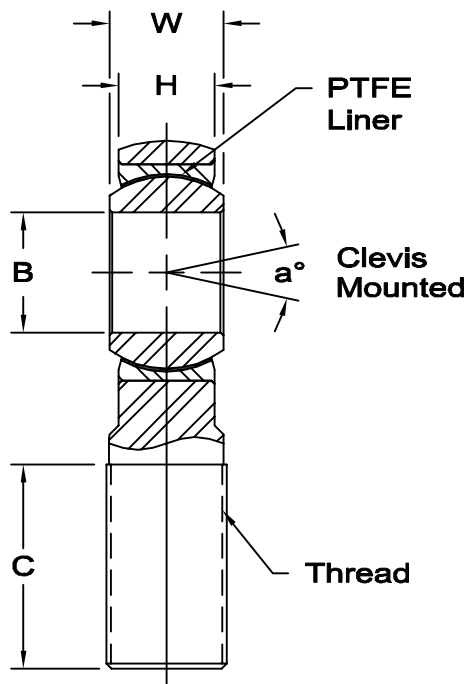
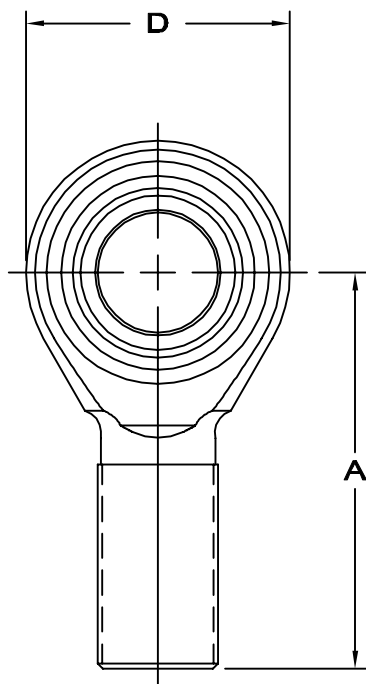

**Body (M-Series)** - Alloy steel, protective coated for corrosion resistance.

**Body (A-Series)** - Alloy steel, heat treated, protective coated for corrosion resistance.

**Race** - Low carbon steel, PTFE lined.

**Ball** - Alloy steel, heat treated, hard chrome plated.

1 Threads 2-12 UN-3A

### M-SERIES – BODY NON HEAT-TREATED

ROD END NO.		DIMENSIONS IN INCHES								a° Misalign. Angle	Ultimate Radial Static Load Capacity Lbs.	Approx. Brg. Wt. Lbs.
Right Hand	Left Hand	B + .0015 - .0005	W ± .005	H ± .020	A ± .040	D ± .030	Ball Dia. Ref.	C + .062 - .031	Thread UNF-3A			
MM-20T	MB-20T	1.2500	1.187	1.000	4.125	2.750	2.000	2.125	1 1/4-12	9.0	31,480	2.41
MM-24T	MB-24T	1.5000	1.375	1.125	5.375	3.500	2.312	3.000	1 1/2-12	8.75	66,264	4.75
MM-32T	MB-32T	2.0000	1.750	1.437	8.000	5.010	2.937	4.500	2-12 <sub>1</sub>	7.5	163,634	14.25

### A-SERIES – BODY HEAT-TREATED

ROD END NO.		DIMENSIONS IN INCHES								a° Misalign. Angle	Ultimate Radial Static Load Capacity Lbs.	Approx. Brg. Wt. Lbs.
Right Hand	Left Hand	B + .0015 - .0005	W ± .005	H ± .020	A ± .040	D ± .030	Ball Dia. Ref.	C + .062 - .031	Thread UNF-3A			
AM-20T	AB-20T	1.2500	1.187	1.000	4.125	2.750	2.000	2.125	1 1/4-12	9.0	65,047	2.41
AM-24T	AB-24T	1.5000	1.375	1.125	5.375	3.500	2.312	3.000	1 1/2-12	8.75	115,610	4.75
AM-32T	AB-32T	2.0000	1.750	1.437	8.000	5.010	2.937	4.500	2-12 <sub>1</sub>	7.5	280,740	14.25

# LARGE BORE SERIES FEMALE ROD ENDS

General Purpose & High Strength – Precision – PTFE Lined



## ROD ENDS 1 1/4", 1 1/2" & 2" SIZES



**Body (M-Series)** - Alloy steel, protective coated for corrosion resistance.

**Body (A-Series)** - Alloy steel, heat treated, protective coated for corrosion resistance.

**Race** - Low carbon steel, PTFE lined.

**Ball** - Alloy steel, heat treated, hard chrome plated.

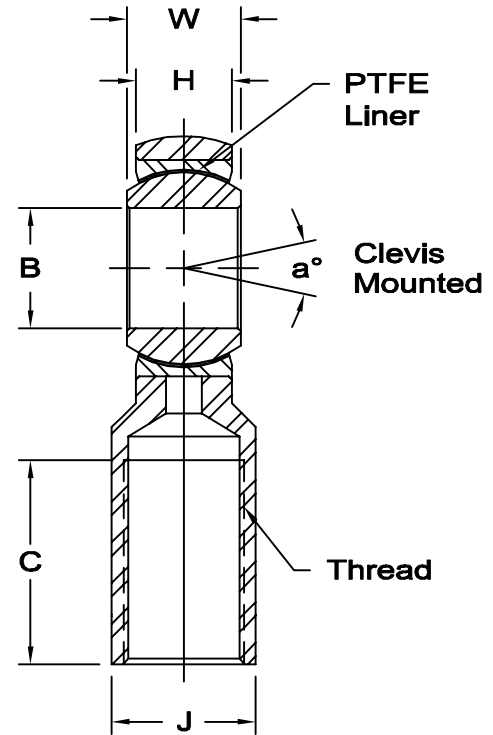
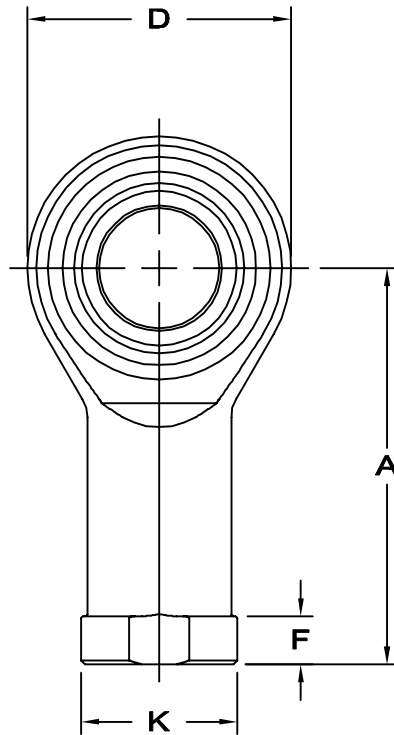

1Threads 2-12 UN-2B

### M-SERIES – BODY NON HEAT-TREATED

ROD END NO.		DIMENSIONS IN INCHES											a° Misalign. Angle	Ultimate Radial Static Load Capacity Lbs.	Approx. Brg. Wt. Lbs.
Right Hand	Left Hand	B + .0015 - .0005	W ± .005	H ± .020	A ± .040	D ± .030	K ± .045	J ± .030	F ± .030	Ball Dia. Ref.	C + .062 - .031	Thread UNF-2B			
MW-20T	MG-20T	1.2500	1.187	1.000	4.125	2.750	1.625	1.500	.500	2.000	2.125	1 1/4-12	9.0	31,480	2.13
MW-24T	MG-24T	1.5000	1.375	1.125	5.375	3.500	2.250	2.000	.875	2.312	2.625	1 1/2-12	8.75	66,264	6.50
MW-32T	MG-32T	2.0000	1.750	1.437	8.000	5.010	3.155	2.750	2.062	2.937	4.000	2-12 <sub>1</sub>	7.5	163,634	15.00

### A-SERIES – BODY HEAT-TREATED

ROD END NO.		DIMENSIONS IN INCHES											a° Misalign. Angle	Ultimate Radial Static Load Capacity Lbs.	Approx. Brg. Wt. Lbs.
Right Hand	Left Hand	B + .0015 - .0005	W ± .005	H ± .020	A ± .040	D ± .030	K ± .045	J ± .030	F ± .030	Ball Dia. Ref.	C + .062 - .031	Thread UNF-2B			
AW-20T	AG-20T	1.2500	1.187	1.000	4.125	2.750	1.625	1.500	.500	2.000	2.125	1 1/4-12	9.0	65,047	2.13
AW-24T	AG-24T	1.5000	1.375	1.125	5.375	3.500	2.250	2.000	.875	2.312	2.625	1 1/2-12	8.75	115,610	6.50
AW-32T	AG-32T	2.0000	1.750	1.437	8.000	5.010	3.155	2.750	2.062	2.937	4.000	2-12 <sub>1</sub>	7.5	280,740	15.00

timkenaurorabearing.com • Fax 630-859-0971



# AM & AB SERIES MALE ROD ENDS

High Strength Alloy – Precision (PTFE Liners Available)

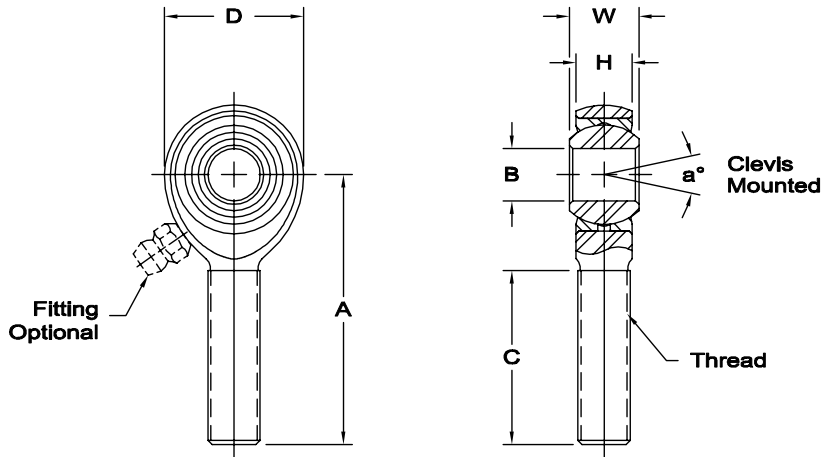

**Body** - Alloy steel, heat treated, protective coated for corrosion resistance.

**Race** - Alloy steel, heat treated, protective coated for corrosion resistance (Low carbon steel with PTFE Liners).

**Ball** - Alloy steel, heat treated, hard chrome plated.

**Notes** - All sizes available with studs upon request.



\* Check for availability.

1 Tolerance variation: "D" ± .020, "A" ± .020, "B" + .0035, - .0005, "H" ± .010  
Check for availability.

2 Tolerance variation: "D" ± .51, "A" ± .51, "B" + .089, - .013, "H" + .25

Check for availability.

3 Threads 1-14 UNS.

Units are supplied without grease fittings. When a grease fitting is required, specify by adding suffix as designated.

Z Zerk type fitting

Ex: AM-6Z

F Flush type fitting

Ex: AM-6F

T PTFE liner

Ex: AM-6T

Load ratings apply only to rod ends without grease fittings. For load ratings with fittings, please consult our engineering department.

ROD END NO.		DIMENSIONS IN INCHES								a° Misalign. Angle	Ultimate Radial Static Load Capacity Lbs.	Approx. Brg. Wt. Lbs.	
Right Hand	Left Hand	B + .0015 - .0005	W + .000 - .005	H ± .005	A ± .010	D ± .010	Ball Dia. Ref.	C + .062 - .031	Thread UNF-3A				
	AM-3	AB-3	.1900	.312	.250	1.250	.625	.437	.750	10-32	13	2,851	.03
	AM-4	AB-4	.2500	.375	.281	1.562	.750	.500	1.000	1/4-28	16	5,260	.04
	AM-5	AB-5	.3125	.437	.344	1.875	.875	.625	1.250	5/16-24	14	7,639	.07
	AM-6	AB-6	.3750	.500	.406	1.938	1.000	.719	1.250	3/8-24	12	9,544	.11
	AM-7	AB-7	.4375	.562	.437	2.125	1.125	.812	1.375	7/16-20	14	10,285	.16
	AM-8	AB-8	.5000	.625	.500	2.438	1.312	.937	1.500	1/2-20	12	16,238	.25
	AM-10	AB-10	.6250	.750	.562	2.625	1.500	1.125	1.625	5/8-18	16	17,955	.38
	AM-12	AB-12	.7500	.875	.687	2.875	1.750	1.312	1.750	3/4-16	14	28,081	.60
	AM-12-20	AB-12-20	.7500	.875	.687	2.875	1.750	1.312	1.750	7/8-14	14	28,081	.72
	AM-14	AB-14	.8750	.875	.765	3.375	2.000	1.375	2.000	7/8-14	7	45,051	.91
*	AM-14-1	AB-14-1	.8750	.875	.687	3.375	2.000	1.312	1.875	7/8-14	12	55,692	.91
1	AM-16	AB-16	1.0000	1.375	1.000	4.125	2.750	1.875	2.125	1 1/4-12	17	76,200	2.41
1	AM-16-1	AB-16-1	1.0000	1.375	1.000	4.125	2.750	1.875	2.125	1-14 <sub>3</sub>	17	76,200	2.13
1	AM-16-2	AB-16-2	1.0000	1.375	1.000	4.125	2.750	1.875	2.125	1-12	17	76,200	2.13

ROD END NO.		DIMENSIONS IN MILLIMETERS								a° Misalign. Angle	Ultimate Radial Static Load Capacity Newtons	Approx. Brg. Wt. Grams	
Right Hand	Left Hand	B + .038 - .013	W + .00 - .13	H ± .13	A ± .25	D ± .25	Ball Dia. Ref.	C + 1.57 - .79	Thread UNF-3A				
	AM-3	AB-3	4.826	7.92	6.35	31.75	15.88	11.10	19.05	10-32	13	12,679	13
	AM-4	AB-4	6.350	9.53	7.14	39.67	19.05	12.70	25.40	1/4-28	16	23,397	20
	AM-5	AB-5	7.938	11.10	8.74	47.63	22.23	15.88	31.75	5/16-24	14	33,978	33
	AM-6	AB-6	9.525	12.70	10.31	49.23	25.40	18.26	31.75	3/8-24	12	42,450	51
	AM-7	AB-7	11.113	14.27	11.10	53.98	28.58	20.62	34.93	7/16-20	14	45,745	73
	AM-8	AB-8	12.700	15.88	12.70	61.93	33.32	23.80	38.10	1/2-20	12	72,231	113
	AM-10	AB-10	15.875	19.05	14.27	66.68	38.10	28.58	41.28	5/8-18	16	79,861	173
	AM-12	AB-12	19.050	22.23	17.45	73.03	44.45	33.32	44.45	3/4-16	14	124,910	273
	AM-12-20	AB-12-20	19.050	22.23	17.45	73.03	44.45	33.32	44.45	7/8-14	14	124,910	273
	AM-14	AB-14	22.225	22.23	19.43	85.73	50.80	34.93	50.80	7/8-14	7	200,387	411
*	AM-14-1	AB-14-1	22.225	22.23	17.45	85.73	50.80	33.32	47.63	7/8-14	12	247,718	411
2	AM-16	AB-16	25.400	34.93	25.40	104.78	69.85	47.63	53.98	1 1/4-12	17	338,937	1,091
2	AM-16-1	AB-16-1	25.400	34.93	25.40	104.78	69.85	47.63	53.98	1-14 <sub>3</sub>	17	338,937	965
2	AM-16-2	AB-16-2	25.400	34.93	25.40	104.78	69.85	47.63	53.98	1-12	17	338,937	965

timkenaurorabearing.com • Fax 630-859-0971



# AW & AG SERIES FEMALE ROD ENDS

High Strength Alloy – Precision (PTFE Liners Available)



**Body** - Alloy steel, heat treated, protective coated for corrosion resistance.

**Race** - Alloy steel, heat treated, protective coated for corrosion resistance (Low carbon steel with PTFE Liners).

**Ball** - Alloy steel, heat treated, hard chrome plated.

**Notes** - All sizes available with studs upon request.

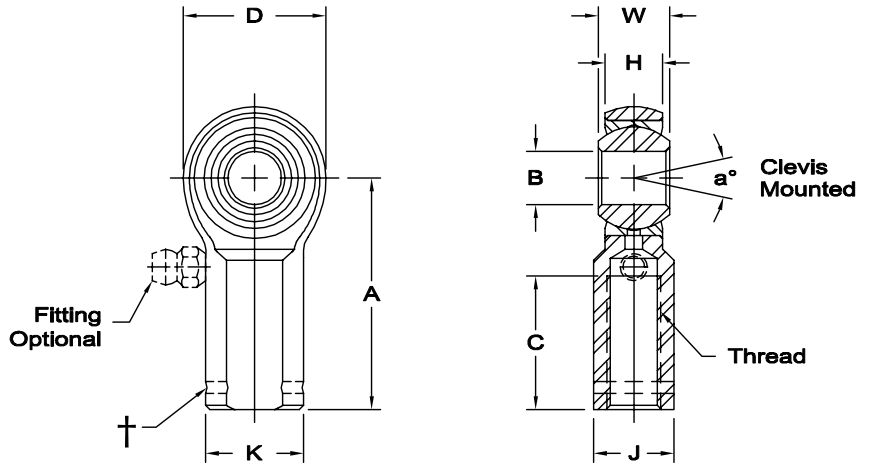

\* Check for availability.

† Left hand units have identification groove near end of shank

1 Tolerance variation: "D" ± .020, "A" + .020 "B" + .0035, -.0005, "H" ± .010, "K" ± .015, "J" ± .015

Check for availability.

2 Tolerance variation: "D" ± .51, "A" + .51 "B" + .089, -.013, "H" ± .25, "K" ± .38, "J" + .38

Check for availability.

3 Threads 1-14 UNS

4 Notes 1 and 2 both have UNF-2B threads.

Units are supplied without grease fittings. When a grease fitting is required, specify by adding suffix as designated.

Z Zerk type fitting

Ex: AW-6Z

F Flush type fitting

Ex: AW-6F

T PTFE liner

Ex: AW-6T

ROD END NO.		DIMENSIONS IN INCHES										a° Misalign. Angle	Ultimate Radial Static Load Capacity Lbs.	Approx. Brg. Wt. Lbs.
Right Hand	Left Hand†	B + .0015 - .0005	W + .000 - .005	H ± .005	A ± .010	D ± .010	K ± .010	J ± .010	Ball Dia. Ref.	C + .062 - .031	Thread UNF-3B			
AW-3	AG-3	.1900	.312	.250	1.062	.625	.406	.312	.437	.562	10-32	13	3,733	.04
AW-4	AG-4	.2500	.375	.281	1.312	.750	.469	.375	.500	.750	1/4-28	16	6,190	.06
AW-5	AG-5	.3125	.437	.344	1.375	.875	.500	.437	.625	.750	5/16-24	14	7,639	.09
AW-6	AG-6	.3750	.500	.406	1.625	1.000	.687	.562	.719	.937	3/8-24	12	9,544	.15
AW-7	AG-7	.4375	.562	.437	1.812	1.125	.750	.625	.812	1.062	7/16-20	14	10,285	.20
AW-8	AG-8	.5000	.625	.500	2.125	1.312	.875	.750	.937	1.187	1/2-20	12	16,238	.33
AW-10	AG-10	.6250	.750	.562	2.500	1.500	1.000	.875	1.125	1.500	5/8-18	16	17,955	.48
AW-12	AG-12	.7500	.875	.687	2.875	1.750	1.125	1.000	1.312	1.750	3/4-16	14	28,081	.72
AW-14	AG-14	.8750	.875	.765	3.375	2.000	1.300	1.125	1.375	1.875	7/8-14	7	45,051	1.03
AW-16	AG-16	1.0000	1.375	1.000	4.125	2.750	1.625	1.500	1.875	2.125	1 1/4-12	17	76,200	2.13
AW-16-1	AG-16-1	1.0000	1.375	1.000	4.125	2.750	1.625	1.500	1.875	2.125	1-14 <sub>3</sub>	17	76,200	2.41
AW-16-2	AG-16-2	1.0000	1.375	1.000	4.125	2.750	1.625	1.500	1.875	2.125	1-12	17	76,200	2.41

ROD END NO.		DIMENSIONS IN MILLIMETERS										a° Misalign. Angle	Ultimate Radial Static Load Capacity Newtons	Approx. Brg. Wt. Grams
Right Hand	Left Hand†	B + .038 - .013	W + .00 - .13	H ± .13	A ± .25	D ± .25	K ± .25	J ± .25	Ball Dia. Ref.	C + 1.57 - .79	Thread UNF-3B			
AW-3	AG-3	4.826	7.92	6.35	26.97	15.88	10.31	7.92	11.10	14.27	10-32	13	16,602	17
AW-4	AG-4	6.350	9.53	7.14	33.32	19.05	11.91	9.53	12.70	19.05	1/4-28	16	27,535	27
AW-5	AG-5	7.938	11.10	8.74	34.93	22.23	12.70	11.10	15.88	19.05	5/16-24	14	33,978	42
AW-6	AG-6	9.525	12.70	10.31	41.28	25.40	17.45	14.27	18.26	23.80	3/8-24	12	42,450	69
AW-7	AG-7	11.113	14.27	11.10	46.02	28.58	19.05	15.88	20.62	26.97	7/16-20	14	45,745	90
AW-8	AG-8	12.700	15.88	12.70	53.98	33.32	22.23	19.05	23.80	30.15	1/2-20	12	72,231	149
AW-10	AG-10	15.875	19.05	14.27	63.50	38.10	25.40	22.23	28.58	38.10	5/8-18	16	79,861	216
AW-12	AG-12	19.050	22.23	17.45	73.03	44.45	28.58	25.40	33.32	44.45	3/4-16	14	124,910	328
AW-14	AG-14	22.225	22.23	19.43	85.73	50.80	33.02	28.58	34.93	47.63	7/8-14	7	200,387	467
AW-16	AG-16	25.400	34.93	25.40	104.78	69.85	41.28	38.10	47.63	53.98	1 1/4-12	17	338,937	964
AW-16-1	AG-16-1	25.400	34.93	25.40	104.78	69.85	41.28	38.10	47.63	53.98	1-14 <sub>3</sub>	17	338,937	1,093
AW-16-2	AG-16-2	25.400	34.93	25.40	104.78	69.85	41.28	38.10	47.63	53.98	1-12	17	338,937	1,093



# XAM & XAB SERIES MALE ROD ENDS

High Strength Alloy – Heavy Duty Shank (PTFE Liners Available)

timkenaurorabearing.com • Fax 630-859-0971

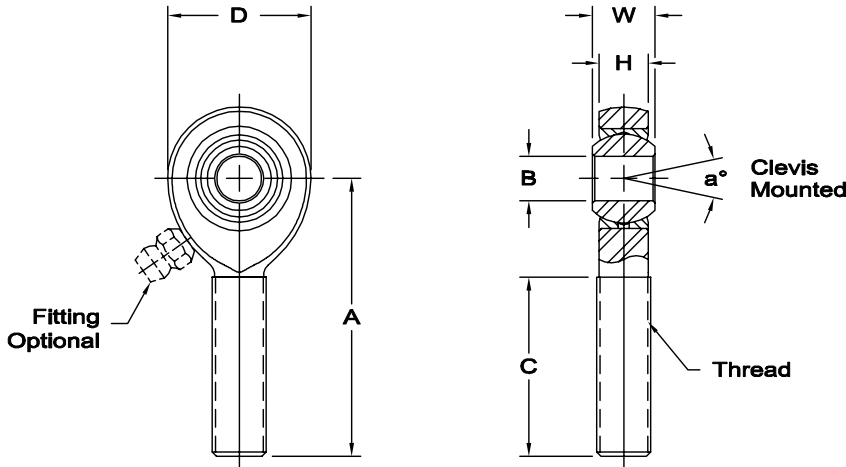

**Body** - Alloy steel, heat treated, protective coated for corrosion resistance.

**Race** - Alloy steel, heat treated, protective coated for corrosion resistance. (Low carbon steel with PTFE liners.)

**Ball** - Alloy steel, heat treated, hard chrome plated.

**Notes** - All sizes available with studs upon request.



Units are supplied without grease fittings. When a grease fitting is required, specify by adding suffix as designated.

Z Zerk type fitting Ex: XAM-6Z

F Flush type fitting Ex: XAM-6F

T PTFE Liner Ex: XAM-6T

Load ratings apply only to rod ends without grease fittings. For load ratings with fittings, please consult our engineering department.

ROD END NO.		DIMENSIONS IN INCHES								a° Misalign. Angle	Ultimate Radial Static Load Capacity Lbs.	Approx. Brg. Wt. Lbs.
Right Hand	Left Hand	B + .0015 - .0005	W + .000 - .005	H ± .005	A ± .015	D ± .010	Ball Dia. Ref.	C + .062 - .031	Thread UNF-3A			
XAM-3	XAB-3	.1900	.312	.250	1.562	.750	.437	1.000	1/4-28	10	5,260	.04
XAM-4	XAB-4	.2500	.375	.281	1.875	.875	.500	1.250	5/16-24	13	8,452	.07
XAM-5	XAB-5	.3125	.437	.344	1.938	1.000	.625	1.250	3/8-24	12	12,978	.11
XAM-6	XAB-6	.3750	.500	.406	2.125	1.125	.719	1.375	7/16-20	10	17,508	.16
XAM-7	XAB-7	.4375	.562	.437	2.438	1.312	.812	1.500	1/2-20	12	23,452	.25
XAM-8	XAB-8	.5000	.625	.500	2.625	1.500	.937	1.625	5/8-18	10	31,390	.38
XAM-10	XAB-10	.6250	.750	.562	2.875	1.750	1.125	1.750	3/4-16	13	40,572	.60
XAM-12	XAB-12	.7500	.875	.687	3.375	2.000	1.312	1.875	7/8-14	12	55,692	.92

ROD END NO.		DIMENSIONS IN MILLIMETERS								a° Misalign. Angle	Ultimate Radial Static Load Capacity Newtons	Approx. Brg. Wt. Grams
Right Hand	Left Hand	B + .038 - .013	W + .00 - .13	H ± .13	A ± .38	D ± .25	Ball Dia. Ref.	C + 1.57 - .79	Thread UNF-3A			
XAM-3	XAB-3	4.826	7.92	6.35	39.67	19.05	11.10	25.40	1/4-28	10	23,397	20
XAM-4	XAB-4	6.350	9.53	7.14	47.63	22.23	12.70	31.75	5/16-24	13	37,596	33
XAM-5	XAB-5	7.938	11.10	8.74	49.23	25.40	15.88	31.75	3/8-24	12	57,728	51
XAM-6	XAB-6	9.525	12.70	10.31	53.98	28.58	18.26	34.93	7/16-20	10	77,880	73
XAM-7	XAB-7	11.113	14.27	11.10	61.93	33.32	20.62	38.10	1/2-20	12	104,317	113
XAM-8	XAB-8	12.700	15.88	12.70	66.68	38.10	23.80	41.28	5/8-18	10	139,628	173
XAM-10	XAB-10	15.875	19.05	14.27	73.02	44.45	28.58	44.45	3/4-16	13	180,461	273
XAM-12	XAB-12	19.050	22.23	17.45	85.73	50.80	33.32	47.63	7/8-14	12	247,721	427

# AM/XAM SERIES SPECIAL SIZE

Special Size Race Car Parts



Parts commonly used in the race car industry, in non standard sizes and dimensions. While not cataloged with standard parts series, many of these are stocked. Check with dealer or factory for availability.

ROD END NO.		DIMENSIONS IN INCHES								a° Misalign. Angle	Ultimate Radial Static Load Capacity Lbs.	Approx. Brg. Wt. Lbs.	
Right Hand	Left Hand	B + .0015 - .0005	W + .000 - .005	H ± .005	A ± .015	D ± .010	Ball Dia. Ref.	C + .062 - .031	Thread UNF-3A				
1	AM-4T-9	AB-4T-9	.2500	.375	.281	1.562	.740	.500	1.000	5/16-24	16	6,158	.06
	AM-6T-6	AB-6T-6	.3750	.500	.406	1.938	1.000	.719	1.219	1/2-20	12	9,544	.15
	AM-6T-7	AB-6T-7	.3750	.625	.500	2.438	1.312	.937	1.500	5/8-18	12	16,238	.32
	AM-6T-15	AB-6T-15	.3750	.625	.500	2.438	1.312	.937	1.500	1/2-20	12	16,238	.28
	XAM-8T-2	XAB-8T-2	.5000	.750	.562	2.875	1.750	1.125	1.750	3/4-16	13	40,572	.60
1	XAM-8T-10	XAB-8T-10	.5000	.750	.562	2.625	1.750	1.125	1.375	5/8-18	13	38,635	.52
	XAM-8T-11	XAB-8T-11	.5000	.750	.562	2.625	1.500	1.125	1.625	5/8-18	16	17,955	.42
1	AM-12T-22	AB-12T-22	.7500	.875	.687	2.875	1.750	1.312	1.750	7/8-14	14	28,081	.72

Body - Alloy steel, heat treated, protective coated for corrosion resistance  
 Race - Low carbon steel, protective coated for corrosion resistance, PTFE lined  
 1 Race - Alloy steel, heat treated, protective coated for corrosion resistance, PTFE lined  
 Ball - Alloy steel, heat treated, hard chrome plated



AM-4T-9



AM-6T-6



XAM-8T-2

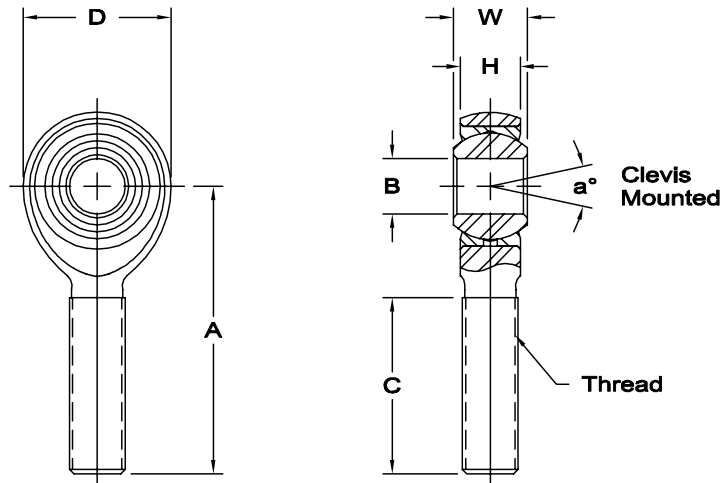

timkenaurorabearing.com • Fax 630-859-0971



# RAM, RAB, RXAM, RXAB SERIES MALE ROD ENDS

High Strength Alloy (PTFE Liners Available)

timkenaurorabearing.com • Fax 630-859-0971

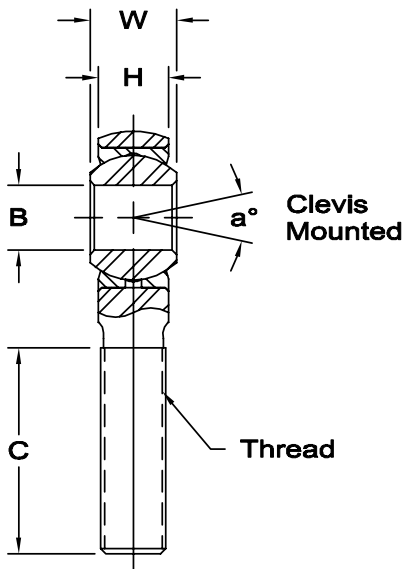
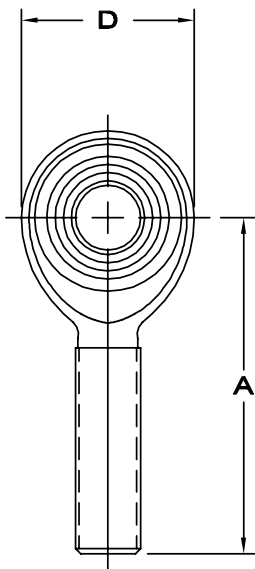

**RAM**

**RXAM**

**Body** - Alloy steel, heat treated, electroless nickel plated.

**Race** - Alloy steel, heat treated, electroless nickel plated.

**Ball** - Alloy steel, heat treated, hard chrome plated.

PTFE Liners use suffix T Ex: RAM-10T

1 Threads UNF-3A

## RAM – HEAVY DUTY

ROD END NO.		DIMENSIONS IN INCHES								a° Misalign. Angle	Ultimate Radial Static Load Capacity Lbs.	Approx. Brg. Wt. Lbs.
Right Hand	Left Hand	B + .0015 - .0005	W + .000 - .005	H ± .005	A ± .010	D + .000 - .020	Ball Dia. Ref.	C + .062 - .031	Thread UNJF-3A			
RAM-3	RAB-3	.1900	.312	.250	1.250	.625	.437	.750	10-32 <sub>1</sub>	13	2,851	.03
RAM-4	RAB-4	.2500	.375	.281	1.562	.750	.500	1.000	1/4-28	16	5,260	.04
RAM-5	RAB-5	.3125	.437	.344	1.875	.875	.625	1.187	5/16-24	14	7,125	.07
RAM-6	RAB-6	.3750	.500	.406	1.938	1.000	.719	1.187	3/8-24	12	8,939	.11
RAM-7	RAB-7	.4375	.562	.437	2.125	1.125	.812	1.312	7/16-20	14	9,653	.16
RAM-8	RAB-8	.5000	.625	.500	2.438	1.312	.937	1.437	1/2-20	12	15,500	.25
RAM-10	RAB-10	.6250	.750	.562	2.625	1.500	1.125	1.562	5/8-18	16	17,148	.38
RAM-10-12	RAB-10-12	.6250	.875	.687	2.875	1.750	1.312	1.687	3/4-16	14	27,021	.60
RAM-12	RAB-12	.7500	.875	.687	2.875	1.750	1.312	1.687	3/4-16	14	27,021	.60

## RXAM – EXTRA HEAVY DUTY

ROD END NO.		DIMENSIONS IN INCHES								a° Misalign. Angle	Ultimate Radial Static Load Capacity Lbs.	Approx. Brg. Wt. Lbs.
Right Hand	Left Hand	B + .0015 - .0005	W + .000 - .005	H ± .005	A ± .010	D + .000 - .020	Ball Dia. Ref.	C + .062 - .031	Thread UNJF-3A			
RXAM-3	RXAB-3	.1900	.312	.250	1.562	.750	.437	1.000	1/4-28	10	5,260	.04
RXAM-4	RXAB-4	.2500	.375	.281	1.875	.875	.500	1.187	5/16-24	13	8,452	.07
RXAM-5	RXAB-5	.3125	.437	.344	1.938	1.000	.625	1.187	3/8-24	12	12,978	.11
RXAM-6	RXAB-6	.3750	.500	.406	2.125	1.125	.719	1.312	7/16-20	10	17,508	.16
RXAM-7	RXAB-7	.4375	.562	.437	2.438	1.312	.812	1.437	1/2-20	12	22,760	.25
RXAM-8	RXAB-8	.5000	.625	.500	2.625	1.500	.937	1.562	5/8-18	10	30,579	.38
RXAM-10	RXAB-10	.6250	.750	.562	2.875	1.750	1.125	1.687	3/4-16	13	39,674	.60

# RAM/RXAM SERIES SPECIAL SIZE

Special Size Race Car Parts



Parts commonly used in the race car industry, in non standard sizes and dimensions. While not cataloged with standard parts series, many of these are stocked. Check with dealer or factory for availability

ROD END NO.		DIMENSIONS IN INCHES								a° Misalign. Angle	Ultimate Radial Static Load Capacity Lbs.	Approx. Brg. Wt. Lbs.		
Right Hand	Left Hand	B +.0015 -.0005	W +.000 -.005	H ±.005	A ±.010	D ±.010	Ball Dia. Ref.	C +.062 -.031	Thread UNJF-3A					
RAM-8T-5	RAB-8T-5	.5000	.750	.687	2.875	1.740	1.312	1.687	3/4-16	4	27,021	.66		
RXAM-8T-3	RXAB-8T-3	.5000	.750	.562	2.875	1.740	1.125	1.687	3/4-16	13	39,674	.60		
RXAM-8T-4	RXAB-8T-4	.5000	.750	.687	3.375	2.000	1.312	1.875	7/8-14	4	55,692	.96		
5	RXAM-12T-1	RXAB-12T-1	.7500	.875	.687	3.375	2.000	1.312	1.875	7/8-14	12	55,692	.92	
	RAM-14T-1	RAB-14T-1	.8750	.875	.765	3.375	2.000	1.375	2.000	7/8-14	7	45,045	.92	
2	4	RXAM-14T-1	RXAB-14T-1	.8750	.875	.765	3.500	2.325	1.375	1.875	1-14	6	84,897	1.28
1	4	RAM-16T-1	RAB-16T-1	1.0000	1.375	1.000	4.125	2.775	1.875	2.125	1-14	17	100,643	2.18
1	3	RAM-16T-3	RAB-16T-3	1.0000	1.375	1.000	4.125	2.775	1.875	2.344	1 1/4-12	17	100,643	2.45

Body - Alloy steel, heat treated, protective coated for corrosion resistance  
 Race - Alloy steel, heat treated, protective coated for corrosion resistance on ends.  
 Ball - Alloy steel, heat treated, hard chrome plated  
 PTFE liner - (AT 3200) Permanently bonded to race inside diameter.

- 1 Tolerance variation: "B" +.0035/- .0005
- 2 Tolerance variation: "A" ±.015
- 3 Tolerance variation: "C" ±.031
- 4 Threads: 1-14UNS-3A
- 5 PTFE Liner - AT1400

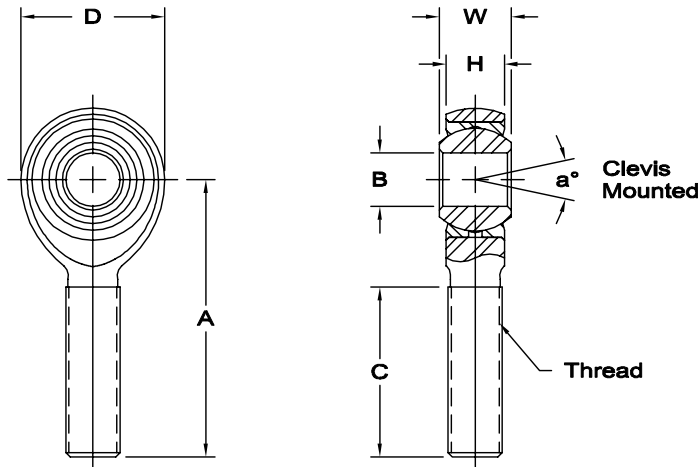

timkenaurorabearing.com • Fax 630-859-0971



# PERFORMANCE RACING SERIES

PRM-T Series Male Rod Ends - PTFE Lined

timkenaurorabearing.com • Fax 630-859-0971

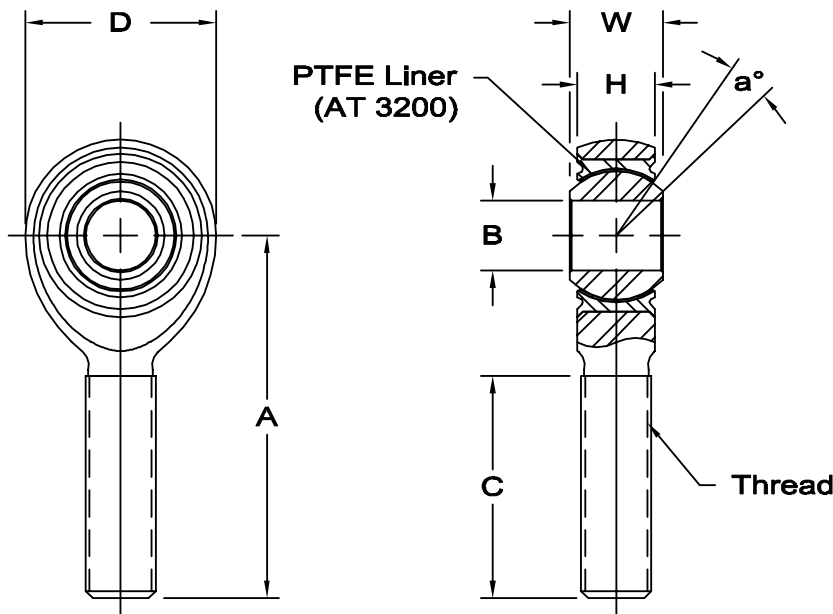

**Body** - 4340 steel, heat treated, protective coated for corrosion resistance.

**Race** - 17-4 PH stainless steel, heat treated

**Ball** - Alloy steel, heat treated, hard chrome plated. Manufacturers option: 440C stainless steel, heat treated.

**PTFE liner** - (AT 3200) Permanently bonded to race inside diameter.

ROD END NO.		DIMENSIONS IN INCHES								a° Misalign. Angle	Ultimate Radial Static Load Capacity Lbs.	No Load Rotational Breakaway Torque In-Lbs.	Approx. Brg. Wt. Lbs.
Right Hand	Left Hand	B + .0000 - .0005	W + .000 - .005	H ± .005	A ± .010	D ± .010	Ball Dia. Ref.	C ± .031	Thread UNJF-3A				
PRM-5T	PRB-5T	.3125	.437	.327	1.875	.900	.593	1.187	5/16-24	14	8,330	1 - 15	.09
PRM-6T	PRB-6T	.3750	.500	.416	1.938	1.025	.687	1.187	3/8-24	8	10,946	1 - 15	.14
PRM-7T	PRB-7T	.4375	.562	.452	2.125	1.150	.781	1.281	7/16-20	10	14,049	1 - 15	.18
PRM-8T	PRB-8T	.5000	.625	.515	2.438	1.337	.875	1.468	1/2-20	9	23,310	1 - 15	.28
PRM-10T	PRB-10T	.6250	.750	.577	2.625	1.525	1.062	1.562	5/8-18	12	25,909	1 - 15	.42
PRM-12T	PRB-12T	.7500	.875	.640	2.875	1.775	1.250	1.687	3/4-16	13	34,319	1 - 15	.64

# PERFORMANCE RACING SERIES

PRXM-T Series Male Rod Ends - PTFE Lined



**Body** - 4340 steel, heat treated, protective coated for corrosion resistance.

**Race** - 17-4 PH stainless steel, heat treated

**Ball** - Alloy steel, heat treated, hard chrome plated. Manufacturers option: 440C stainless steel, heat treated.

**PTFE liner** - (AT 3200)  
Permanently bonded to race inside diameter.

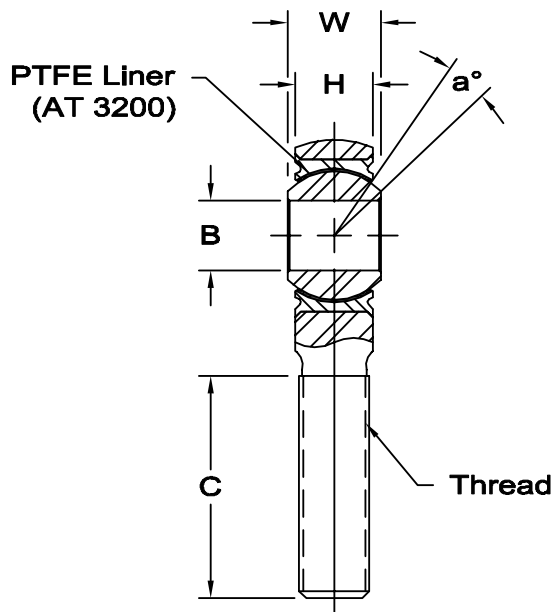
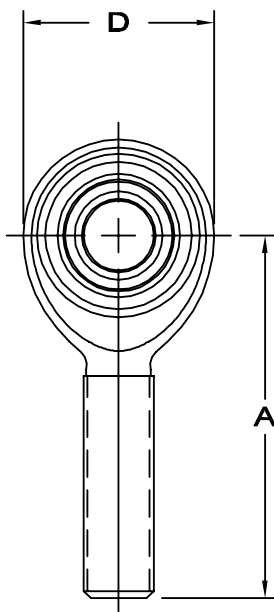

timkenaurorabearing.com • Fax 630-859-0971

ROD END NO.		DIMENSIONS IN INCHES								a° Misalign. Angle	Ultimate Radial Static Load Capacity Lbs.	No Load Rotational Breakaway Torque In-Lbs.	Approx. Brg. Wt. Lbs.
Right Hand	Left Hand	B + .0000 - .0005	W + .000 - .005	H ± .005	A ± .010	D ± .010	Ball Dia. Ref.	C ± .031	Thread UNJF-3A				
PRXM-4T	PRXB-4T	.2500	.375	.337	1.562	.806	.531	.968	5/16-24	6	7,544	.5 - 6	.07
PRXM-5T	PRXB-5T	.3125	.437	.327	1.875	.900	.593	1.187	3/8 - 24	14	9,135	1 - 15	.10
PRXM-6T	PRXB-6T	.3750	.500	.416	1.938	1.025	.687	1.187	7/16-20	8	10,946	1 - 15	.15
PRXM-7T	PRXB-7T	.4375	.562	.452	2.125	1.150	.781	1.281	1/2-20	10	14,049	1 - 15	.19
PRXM-8T	PRXB-8T	.5000	.625	.515	2.438	1.337	.875	1.468	5/8-18	9	23,310	1 - 15	.32
PRXM-10T	PRXB-10T	.6250	.750	.577	2.625	1.525	1.062	1.562	3/4-16	12	25,909	1 - 15	.46

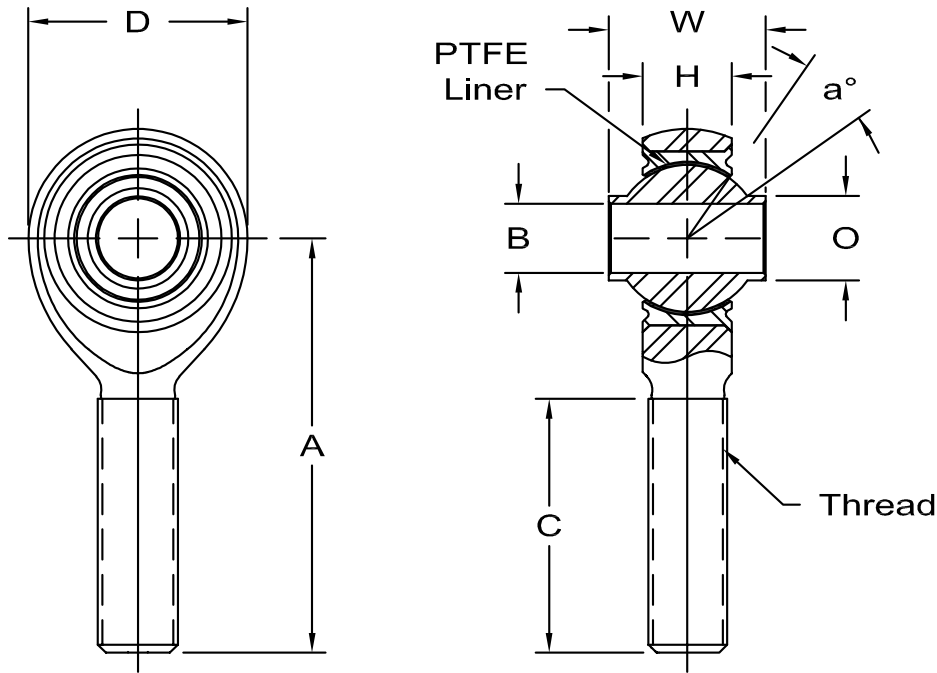

**Body** - 4340 steel, heat treated, protective coated for corrosion resistance.

**Race** - 17-4 PH stainless steel, heat treated

**Ball** - Alloy steel, heat treated, hard chrome plated.

**PTFE liner** - (AT 3200)  
Permanently bonded to race inside diameter.

ROD END NO.		DIMENSIONS IN INCHES									a° Misalign. Angle	Ultimate Radial Static Load Capacity Lbs.	Approx. Brq. Wt. Lbs.
Right Hand	Left Hand	B +.0000 -.0005	W +.000 -.005	H ±.005	A ±.010	D ±.010	Ball Dia. Ref.	C ±.031	Thread UNJF-3A	O Shoulder Dia.			
HXAM-3T	HXAB-3T	.1900	.500	.220	1.562	.806	.437	1.000	5/16-24	.317	17	7,310	.06
HXAM-4T	HXAB-4T	.2500	.593	.265	1.938	1.025	.593	1.187	3/8-24	.390	23	10,789	.12
HXAM-5T	HXAB-5T	.3125	.813	.355	2.125	1.150	.781	1.281	7/16-20	.512	22	11,781	.16
HXAM-6T	HXAB-6T	.3750	.813	.355	2.125	1.150	.781	1.281	7/16-20	.512	22	11,781	.15
HXAM-7T	HXAB-7T	.4375	.875	.355	2.438	1.337	.875	1.468	1/2-20	.618	21	17,105	.24
HXAM-8T	HXAB-8T	.5000	.937	.411	2.625	1.525	1.000	1.562	5/8-18	.730	19	23,720	.39
HXAM-10T	HXAB-10T	.6250	1.200	.577	2.875	1.775	1.250	1.687	3/4-16	.856	19	32,067	.60
HXAM-12T	HXAB-12T	.7500	1.280	.630	3.375	2.025	1.375	2.000	7/8-14	.970	18	38,660	.89



Beyond rod ends and spherical bearings for installation into customer components, Timken Aurora Bearing also manufactures linkages on a special order basis. Linkages can be combined with male or female rod ends and the appropriate connector, resulting in linkages with adjustable centers, or the appropriate rod end or spherical insert can be incorporated into a fixed length linkage. Linkages are not normally stocked, and minimum order quantities are required. Virtually all Aurora products, in inch or metric series, can be incorporated in these custom engineered products. Contact Aurora sales for further information.

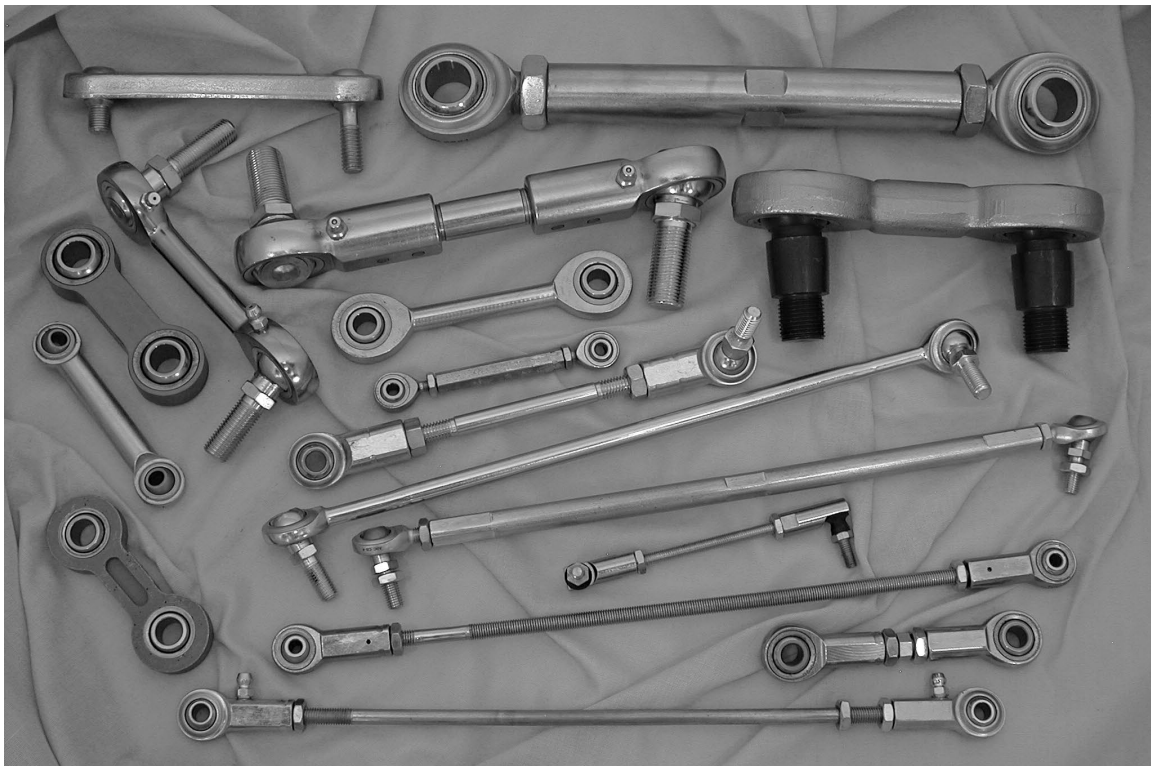



# COM & HCOM SERIES SPHERICAL BEARINGS

(PTFE Liners Available)<sup>1</sup>

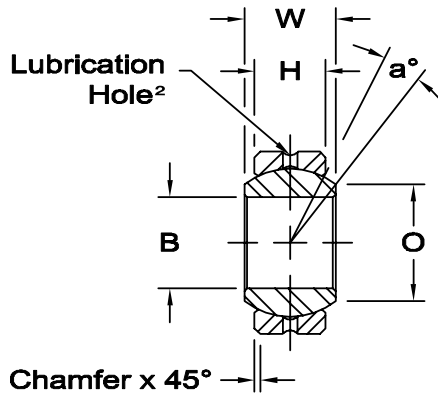
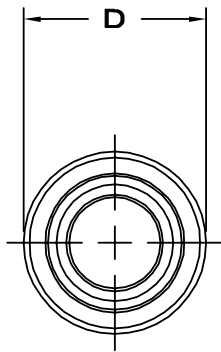

**Race** - Low carbon steel, I.D. protective coated for corrosion resistance.

**Ball** - Alloy steel, heat treated, hard chrome plated.

**M Chamfer x 45°**

\* Bore tolerance on these items is as follows -  
INCH: +.0025, -.0005; METRIC: +.064, -.013

1 PTFE Liners use suffix T Ex: COM-10T  
2 PTFE Lined parts have no lubrication groove in race.  
Hole manufactures option.

BEARING NO.	DIMENSIONS IN INCHES							a° Misalign. Angle	Radial Static Limit Load Capacity Lbs.	Approx. Brg. Wt. Lbs.
	B +.0015 -.0005	D +.0000 -.0007	H ±.005	W ±.005	O Flat Dia Ref.	M Chamfer Ref.	Ball Dia Ref.			
COM-3	.1900	.5625	.218	.281	.293	.015	.406	11	3,250	.01
COM-4	.2500	.6562	.250	.343	.364	.022	.500	13.5	4,950	.02
COM-5	.3125	.7500	.281	.375	.419	.032	.562	12	6,475	.03
COM-6	.3750	.8125	.312	.406	.516	.032	.656	10	8,400	.04
COM-7	.4375	.9062	.343	.437	.530	.032	.687	8	9,453	.05
COM-8	.5000	1.0000	.390	.500	.640	.032	.813	9.5	13,250	.07
COM-9	.5625	1.0937	.437	.562	.710	.032	.906	9.5	16,630	.09
COM-10	.6250	1.1875	.500	.625	.780	.032	1.000	8.5	21,280	.11
COM-12	.7500	1.4375	.593	.750	.920	.044	1.187	9	31,920	.20
COM-14	.8750	1.5625	.703	.875	.980	.044	1.312	9.5	41,960	.26
*COM-16	1.0000	1.7500	.797	1.000	1.118	.044	1.500	10	55,200	.39
*HCOM-16	1.0000	2.0000	.781	1.000	1.360	.032	1.687	9	70,820	.55
*HCOM-19	1.1875	2.3750	.937	1.187	1.610	.032	2.000	8.5	100,730	.90
*HCOM-20	1.2500	2.3750	.937	1.187	1.610	.032	2.000	8.5	100,730	.90
*HCOM-24	1.5000	2.7500	1.094	1.375	1.860	.032	2.312	8.5	135,950	1.36
*HCOM-28	1.7500	3.1250	1.250	1.562	2.110	.044	2.625	8	176,370	1.95
*HCOM-32	2.0000	3.5000	1.375	1.750	2.360	.044	2.937	8.5	217,060	2.65

BEARING NO.	DIMENSIONS IN MILLIMETERS							a° Misalign. Angle	Radial Static Limit Load Capacity Newtons	Approx. Brg. Wt. Grams
	B +.038 -.013	D +.000 -.018	H ±.13	W ±.13	O Flat Dia Ref.	M Chamfer Ref.	Ball Dia Ref.			
COM-3	4.826	14.29	5.54	7.14	7.44	.38	10.31	11	14,464	6
COM-4	6.350	16.67	6.35	8.71	9.25	.56	12.70	13.5	22,015	10
COM-5	7.938	19.05	7.14	9.53	10.64	.81	14.27	12	28,800	14
COM-6	9.525	20.64	7.92	10.31	13.11	.81	16.66	10	37,361	17
COM-7	11.113	23.02	8.71	11.10	13.46	.81	17.45	8	42,048	21
COM-8	12.700	25.40	9.91	12.70	16.26	.81	20.65	9.5	58,934	29
COM-9	14.288	27.78	11.10	14.27	18.03	.81	23.01	9.5	73,967	39
COM-10	15.875	30.16	12.70	15.88	19.81	.81	25.40	8.5	94,658	50
COM-12	19.050	36.51	15.06	19.05	23.37	1.12	30.15	9	141,982	93
COM-14	22.225	39.69	17.86	22.23	24.89	1.12	33.32	9.5	186,639	119
*COM-16	25.400	44.45	20.24	25.40	28.40	1.12	38.10	10	245,534	175
*HCOM-16	25.400	50.80	19.84	25.40	34.54	.81	42.85	9	315,010	251
*HCOM-19	30.163	60.33	23.80	30.15	40.89	.81	50.80	8.5	448,049	406
*HCOM-20	31.750	60.33	23.80	30.15	40.89	.81	50.80	8.5	448,049	406
*HCOM-24	38.100	69.85	27.79	34.93	47.24	.81	58.72	8.5	604,710	616
*HCOM-28	44.450	79.38	31.75	39.67	53.59	1.12	66.68	8	784,495	884
*HCOM-32	50.800	88.90	34.93	44.45	59.94	1.12	74.60	8.5	965,485	1,198

For suggested housing bores, see page 110

timkenaurorabearing.com • Fax 630-859-0971

# COM-KH & HCOM-KH SERIES SPHERICAL BEARINGS

(PTFE Liners Available)<sup>1</sup>

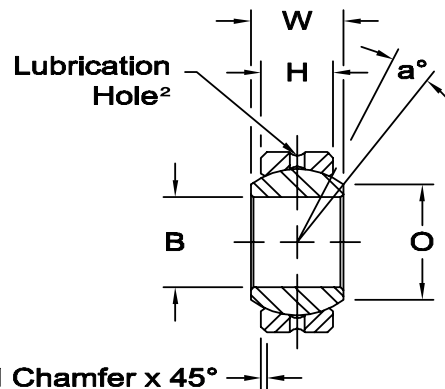
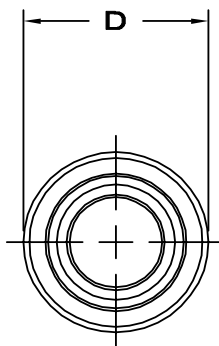

**Race** - Alloy steel, heat treated, I.D. protective coated for corrosion resistance.

**Ball** - Alloy steel, heat treated, hard chrome plated.

\* Check for availability

1 PTFE Liners use suffix T Ex: COM-6TKH

2 PTFE Lined parts have no lubrication groove in race. Hole manufactures option.

† Bore tolerance on these items is as follows - INCH: +.0025, -.0005; METRIC: +.064, -.013

BEARING NO.	DIMENSIONS IN INCHES							a° Misalign. Angle	Radial Static Limit Load Capacity Lbs.	Approx. Brg. Wt. Lbs.
	B +.0015 -.0005	D +.0000 -.0007	H ± .005	W ± .005	O Flat Dia Ref.	M Chamfer Ref.	Ball Dia Ref.			
* COM-3KH	.1900	.5625	.218	.281	.293	.015	.406	11	4,875	.01
* COM-4KH	.2500	.6562	.250	.343	.364	.022	.500	13.5	7,425	.02
* COM-5KH	.3125	.7500	.281	.375	.419	.032	.562	12	9,713	.03
COM-6KH	.3750	.8125	.312	.406	.516	.032	.656	10	12,600	.04
* COM-7KH	.4375	.9062	.343	.437	.530	.032	.687	8	14,180	.05
COM-8KH	.5000	1.0000	.390	.500	.640	.032	.813	9.5	19,875	.07
* COM-9KH	.5625	1.0937	.437	.562	.710	.032	.906	9.5	24,945	.09
COM-10KH	.6250	1.1875	.500	.625	.780	.032	1.000	8.5	31,920	.11
COM-12KH	.7500	1.4375	.593	.750	.920	.044	1.187	9	47,880	.20
* COM-14KH	.8750	1.5625	.703	.875	.980	.044	1.312	9.5	62,940	.26
* †COM-16KH	1.0000	1.7500	.797	1.000	1.118	.044	1.500	10	82,800	.39
* †HCOM-16KH	1.0000	2.0000	.781	1.000	1.360	.032	1.687	9	106,230	.55
* †HCOM-19KH	1.1875	2.3750	.937	1.187	1.610	.032	2.000	8.5	151,095	.90
* †HCOM-20KH	1.2500	2.3750	.937	1.187	1.610	.032	2.000	8.5	151,095	.90
* †HCOM-24KH	1.5000	2.7500	1.094	1.375	1.860	.032	2.312	8.5	203,925	1.36
* †HCOM-28KH	1.7500	3.1250	1.250	1.562	2.110	.044	2.625	8	264,555	1.95
* †HCOM-32KH	2.0000	3.5000	1.375	1.750	2.360	.044	2.937	8.5	325,590	2.65

BEARING NO.	DIMENSIONS IN MILLIMETERS							a° Misalign. Angle	Radial Static Limit Load Capacity Newtons	Approx. Brg. Wt. Grams
	B +.038 -.013	D +.000 -.018	H ± .13	W ± .13	O Flat Dia Ref.	M Chamfer Ref.	Ball Dia Ref.			
* COM-3KH	4.826	14.29	5.54	7.14	7.44	.38	10.31	11	21,701	6
* COM-4KH	6.350	16.67	6.35	8.71	9.25	.56	12.70	13.5	33,027	10
* COM-5KH	7.938	19.05	7.14	9.53	10.64	.81	14.27	12	43,206	14
COM-6KH	9.525	20.64	7.92	10.31	13.11	.81	16.66	10	56,042	17
* COM-7KH	11.113	23.02	8.71	11.10	13.46	.81	17.45	8	63,073	21
COM-8KH	12.700	25.40	9.91	12.70	16.26	.81	20.65	9.5	88,402	29
* COM-9KH	14.288	27.78	11.10	14.27	18.03	.81	23.01	9.5	110,956	39
COM-10KH	15.875	30.16	12.70	15.88	19.81	.81	25.40	8.5	141,992	50
COM-12KH	19.050	36.51	15.06	19.05	23.37	1.12	30.15	9	212,988	93
* COM-14KH	22.225	39.69	17.86	22.23	24.89	1.12	33.32	9.5	279,963	119
* †COM-16KH	25.400	44.45	20.24	25.40	28.40	1.12	38.10	10	368,306	175
* †HCOM-16KH	25.400	50.80	19.84	25.40	34.54	.81	42.85	9	472,515	251
* †HCOM-19KH	30.163	60.33	23.80	30.15	40.89	.81	50.80	8.5	672,078	406
* †HCOM-20KH	31.750	60.33	23.80	30.15	40.89	.81	50.80	8.5	672,078	406
* †HCOM-24KH	38.100	69.85	27.79	34.93	47.24	.81	58.72	8.5	907,061	616
* †HCOM-28KH	44.450	79.38	31.75	39.67	53.59	1.12	66.68	8	1,176,747	884
* †HCOM-32KH	50.800	88.90	34.93	44.45	59.94	1.12	74.60	8.5	1,448,228	1,198

For suggested housing bores, see page 110

timkenaurorabearing.com • Fax 630-859-0971



# COM-E SERIES SPHERICAL BEARINGS

(PTFE Liners Available)<sup>1</sup>

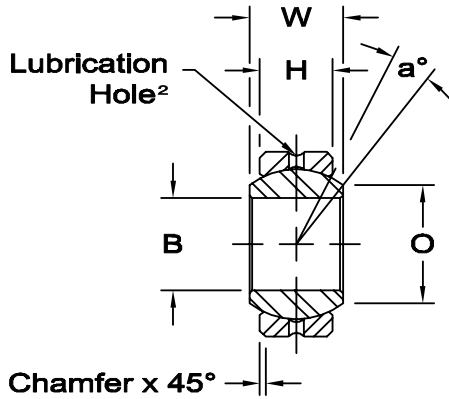
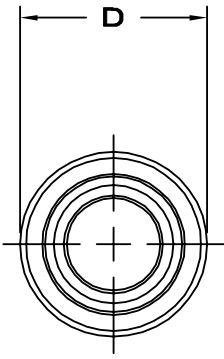

**Race** - 17-4 PH stainless steel, heat treated.

**Ball** - 440 C stainless steel, heat treated, chrome plated. (MFG. Option).



timkenaurorabearing.com • Fax 630-859-0971

Check for availability on all sizes.

<sup>1</sup> PTFE Liners use suffix T Ex: COM-6ET

<sup>2</sup> PTFE Lined parts have no lubrication groove in race. Hole manufactures option.

BEARING NO.	DIMENSIONS IN INCHES							a° Misalign. Angle	Radial Static Limit Load Capacity Lbs.	Approx. Brg. Wt. Lbs.
	B +.0015 -.0005	D +.0000 -.0007	H ±.005	W ±.005	O Flat Dia Ref.	M Chamfer Ref.	Ball Dia Ref.			
COM-3E	.1900	.5625	.218	.281	.293	.015	.406	11	4,875	.01
COM-4E	.2500	.6562	.250	.343	.364	.022	.500	13.5	7,425	.02
COM-5E	.3125	.7500	.281	.375	.419	.032	.562	12	9,713	.03
COM-6E	.3750	.8125	.312	.406	.475	.032	.625	10	12,600	.04
COM-7E	.4375	.9062	.343	.437	.530	.032	.687	8	14,180	.05
COM-8E	.5000	1.0000	.390	.500	.600	.032	.781	9.5	19,875	.07
COM-9E	.5625	1.0937	.437	.562	.670	.032	.875	9.5	24,945	.09
COM-10E	.6250	1.1875	.500	.625	.739	.032	1.000	8.5	28,438	.11
COM-12E	.7500	1.4375	.593	.750	.920	.044	1.187	9	47,880	.20
COM-14E	.8750	1.5625	.703	.875	.980	.044	1.312	9.5	62,940	.26
COM-16E	1.0000	1.7500	.797	1.000	1.118	.044	1.500	10	82,800	.39

BEARING NO.	DIMENSIONS IN MILLIMETERS							a° Misalign. Angle	Radial Static Limit Load Capacity Newtons	Approx. Brg. Wt. Grams
	B +.038 -.013	D +.000 -.018	H ±.13	W ±.13	O Flat Dia Ref.	M Chamfer Ref.	Ball Dia Ref.			
COM-3E	4.826	14.29	5.54	7.14	7.44	.38	10.31	11	21,701	6
COM-4E	6.350	16.67	6.35	8.71	9.25	.56	12.70	13.5	33,027	10
COM-5E	7.938	19.05	7.14	9.53	10.64	.81	14.27	12	43,206	14
COM-6E	9.525	20.64	7.92	10.31	12.06	.81	15.88	10	56,042	17
COM-7E	11.113	23.02	8.71	11.10	13.46	.81	17.45	8	63,073	21
COM-8E	12.700	25.40	9.91	12.70	15.24	.81	19.84	9.5	88,402	29
COM-9E	14.288	27.78	11.10	14.27	17.02	.81	22.23	9.5	110,956	39
COM-10E	15.875	30.16	12.70	15.88	18.77	.81	25.40	8.5	126,492	50
COM-12E	19.050	36.51	15.06	19.05	23.37	1.12	30.15	9	212,988	93
COM-14E	22.225	39.69	17.86	22.23	24.89	1.12	33.32	9.5	279,963	119
COM-16E	25.400	44.45	20.24	25.40	28.40	1.12	38.10	10	368,306	175

For suggested housing bores, see page 110

# LCOM SERIES LARGE SIZE SPHERICAL BEARINGS

(PTFE Liners Available)<sup>1</sup>



**Outer Member** - Low carbon steel, protective coated for corrosion resistance.

**Race** - Low carbon steel, exposed surfaces after installation protective coated for corrosion resistance.

**Ball** - Alloy steel, heat treated, hard chrome plated.

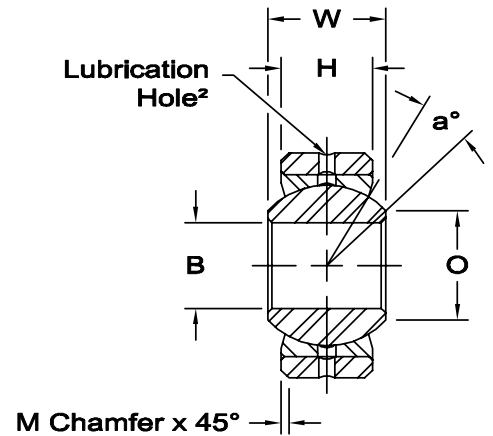
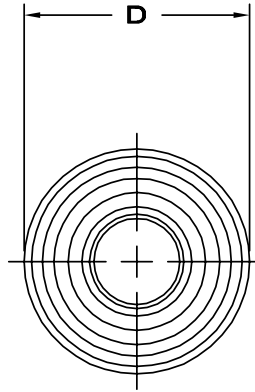

THESE BEARINGS NOT NORMALLY STOCKED - CHECK FOR AVAILABILITY.

1 PTFE Liners use suffix T Ex: LCOM-6T  
2 PTFE Lined parts have no lubrication groove in outer member.

BEARING NO.	DIMENSIONS IN INCHES							a° Misalign. Angle	Radial Static Limit Load Capacity Lbs.	Approx. Brg. Wt. Lbs.
	B +.0015 -.0005	D +.0000 -.0007	H ±.005	W ±.005	O Flat Dia Ref.	M Chamfer Ref.	Ball Dia Ref.			
LCOM-3	.1900	.6250	.187	.281	.293	.016	.406	16	3,037	.02
LCOM-4	.2500	.7500	.281	.375	.331	.016	.500	14	5,620	.04
LCOM-5	.3125	.8750	.313	.437	.448	.016	.625	14	7,825	.05
LCOM-6	.3750	1.0000	.375	.500	.516	.016	.719	12	10,785	.08
LCOM-7	.4375	1.1875	.437	.562	.586	.032	.812	11	14,194	.12
LCOM-8	.5000	1.3125	.531	.687	.637	.044	.937	12	19,902	.18
LCOM-10	.6250	1.5625	.687	.875	.802	.044	1.187	12	32,619	.33
LCOM-12	.7500	2.2500	.937	1.250	1.038	.044	1.625	15	60,905	.97
LCOM-12-1	.7500	1.8750	.687	.875	.978	.044	1.312	10	36,054	.52
LCOM-16	1.0000	2.3750	.875	1.125	1.345	.062	1.750	10	61,250	.94
LCOM-19	1.1875	2.6250	1.000	1.250	1.562	.085	2.000	8.5	80,000	1.27
LCOM-24	1.5000	3.2500	1.250	1.500	2.000	.085	2.500	7	125,000	2.38
LCOM-30	1.8750	4.0000	1.313	1.625	2.521	.125	3.000	7	157,560	3.75

BEARING NO.	DIMENSIONS IN MILLIMETERS							a° Misalign. Angle	Radial Static Limit Load Capacity Newtons	Approx. Brg. Wt. Grams
	B +.038 -.013	D +.000 -.018	H ±.13	W ±.13	O Flat Dia Ref.	M Chamfer Ref.	Ball Dia Ref.			
LCOM-3	4.826	15.88	4.75	7.14	7.44	.41	10.31	16	13,509	9
LCOM-4	6.350	19.05	7.14	9.53	8.41	.41	12.70	14	24,998	18
LCOM-5	7.938	22.23	7.95	11.10	11.38	.41	15.88	14	34,806	22
LCOM-6	9.525	25.40	9.53	12.70	13.11	.41	18.26	12	47,972	36
LCOM-7	11.113	30.16	11.10	14.27	14.88	.81	20.62	11	63,135	54
LCOM-8	12.700	33.34	13.49	17.45	16.18	1.12	23.80	12	88,524	82
LCOM-10	15.875	39.69	17.45	22.23	20.37	1.12	30.15	12	145,089	150
LCOM-12	19.050	57.15	23.80	31.75	26.37	1.12	41.28	15	270,905	440
LCOM-12-1	19.050	47.63	17.45	22.23	24.84	1.12	33.32	10	160,368	236
LCOM-16	25.400	60.33	22.23	28.56	34.16	1.57	44.45	10	272,440	426
LCOM-19	30.163	66.68	25.40	31.75	39.67	2.16	50.80	8.5	355,840	576
LCOM-24	38.100	82.55	31.75	38.10	50.80	2.16	63.50	7	556,000	1,080
LCOM-30	47.625	101.60	33.35	41.28	64.03	3.18	76.20	7	700,826	1,701

For suggested housing bores, see page 111

timkenaurorabearing.com • Fax 630-859-0971

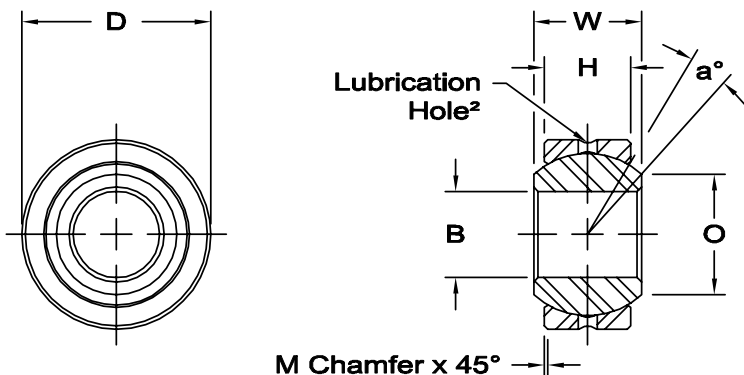

**Race** - Low carbon steel, I.D. protective coated for corrosion resistance.

**Ball** - Alloy steel, heat treated, hard chrome plated.

**Notes** - All sizes available with studs upon request.



\*Bore Tolerance on these items is as follows -  
INCH: +.0035, -.0005; METRIC: +.089, -.013

1 PTFE Liners use suffix T Ex: MIB-6T

2 PTFE Lined parts have no lubrication groove in race.  
Hole manufactures option.

BEARING NO.	DIMENSIONS IN INCHES							a° Misalign. Angle	Radial Static Limit Load Capacity Lbs.	Approx. Brg. Wt. Lbs.
	B + .0015 - .0005	D + .0000 - .0007	H ± .005	W + .000 - .005	O Flat Dia. Ref.	M Chamfer Ref.	Ball Dia. Ref.			
MIB-2	.1250	.4062	.187	.250	.187	.025	.312	17	2,533	.02
MIB-3	.1900	.5312	.250	.312	.307	.020	.437	10.5	4,370	.02
MIB-4	.2500	.6094	.281	.375	.331	.020	.500	14.5	5,620	.02
MIB-5	.3125	.7500	.344	.437	.448	.020	.625	11	8,600	.04
MIB-6	.3750	.8437	.406	.500	.516	.020	.719	9.5	11,677	.06
MIB-7	.4375	1.0000	.437	.562	.587	.020	.812	11	14,194	.08
MIB-8	.5000	1.0937	.500	.625	.699	.020	.937	9.5	18,740	.11
MIB-10	.6250	1.3125	.562	.750	.839	.030	1.125	12	25,290	.17
MIB-12	.7500	1.5000	.687	.875	.978	.030	1.312	10	32,448	.25
MIB-14	.8750	1.6250	.750	.875	1.061	.035	1.375	6	39,653	.35
MIB-16*	1.0000	2.1250	1.000	1.375	1.275	.060	1.875	15	60,000	.79

BEARING NO.	DIMENSIONS IN MILLIMETERS							a° Misalign. Angle	Radial Static Limit Load Capacity Newtons	Approx. Brg. Wt. Grams
	B + .038 - .013	D + .000 - .013	H ± .13	W + .00 - .13	O Flat Dia. Ref.	M Chamfer Ref.	Ball Dia. Ref.			
MIB-2	3.175	10.31	4.74	6.35	4.74	.63	7.92	17	11,266	7
MIB-3	4.826	13.49	6.35	7.92	7.79	.50	11.10	10.5	19,438	7
MIB-4	6.350	15.47	7.13	9.52	8.40	.50	12.70	14.5	24,998	10
MIB-5	7.938	19.05	8.73	11.10	11.37	.50	15.87	11	38,253	18
MIB-6	9.525	21.43	10.31	12.70	13.10	.50	18.26	9.5	51,939	27
MIB-7	11.113	25.40	11.10	14.27	14.91	.50	20.62	11	63,135	36
MIB-8	12.700	27.78	12.70	15.87	17.75	.50	23.80	9.5	83,356	50
MIB-10	15.875	33.33	14.27	19.05	21.31	.76	28.57	12	112,490	75
MIB-12	19.050	38.10	17.45	22.23	24.84	.76	33.32	10	144,329	114
MIB-14	22.225	41.28	19.05	22.23	26.95	.89	34.93	6	176,637	159
MIB-16*	25.400	53.97	25.40	34.92	32.38	1.52	47.62	15	266,880	358

# AIB SERIES

Spherical Bearings (PTFE Liners Available)<sup>1</sup>



**Race** - Alloy steel, heat treated, I.D. protective coated for corrosion resistance, oil coated.

**Ball** - Alloy steel, heat treated, hard chrome plated.

**Notes** - All sizes available with studs upon request.

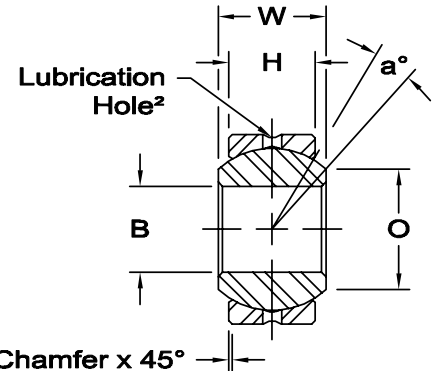
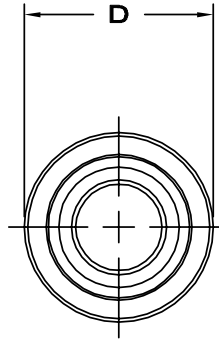

M Chamfer x 45°

\*Bore Tolerance on these items is as follows -  
INCH: +.0035, -.0005; METRIC: +.089, -.013  
\*\*Check for availability

1 PTFE Liners use suffix T Ex: AIB-6T  
2 PTFE Lined parts have no lubrication groove in race.  
Hole manufactures option.

BEARING NO.	DIMENSIONS IN INCHES							a° Misalign. Angle	Radial Static Limit Load Capacity Lbs.	Approx. Brg. Wt. Lbs.
	B +.0015 -.0005	D +.0000 -.0007	H ± .005	W + .000 - .005	O Flat Dia. Ref.	M Chamfer Ref.	Ball Dia. Ref.			
** AIB-2	.1250	.4062	.187	.250	.187	.025	.312	17	4,110	.02
AIB-3	.1900	.5312	.250	.312	.307	.020	.437	10.5	6,555	.02
AIB-4	.2500	.6094	.281	.375	.331	.020	.500	14.5	8,430	.02
AIB-5	.3125	.7500	.344	.437	.448	.020	.625	11	12,900	.04
AIB-6	.3750	.8437	.406	.500	.516	.020	.719	9.5	17,516	.06
AIB-7	.4375	1.0000	.437	.562	.587	.020	.812	11	21,291	.08
AIB-8	.5000	1.0937	.500	.625	.699	.020	.937	9.5	28,110	.11
AIB-10	.6250	1.3125	.562	.750	.839	.030	1.125	12	37,935	.17
AIB-12	.7500	1.5000	.687	.875	.978	.030	1.312	10	48,672	.25
AIB-14	.8750	1.6250	.750	.875	1.061	.035	1.375	6	58,653	.35
* AIB-16	1.0000	2.1250	1.000	1.375	1.275	.060	1.875	15	90,000	.79

BEARING NO.	DIMENSIONS IN MILLIMETERS							a° Misalign. Angle	Radial Static Limit Load Capacity Newtons	Approx. Brg. Wt. Grams
	B + .038 - .013	D + .000 - .013	H ± .13	W + .00 - .13	O Flat Dia. Ref.	M Chamfer Ref.	Ball Dia. Ref.			
** AIB-2	3.175	10.31	4.74	6.35	4.74	.63	7.92	17	18,281	7
AIB-3	4.826	13.49	6.35	7.92	7.79	.5	11.10	10.5	29,157	7
AIB-4	6.350	15.47	7.13	9.52	8.40	.5	12.70	14.5	37,497	10
AIB-5	7.938	19.05	8.73	11.10	11.37	.5	15.87	11	57,379	18
AIB-6	9.525	21.43	10.31	12.70	13.10	.5	18.26	9.5	77,911	27
AIB-7	11.113	25.40	11.10	14.27	14.91	.5	20.62	11	94,702	36
AIB-8	12.700	27.78	12.70	15.87	17.75	.5	23.80	9.5	125,033	50
AIB-10	15.875	33.33	14.27	19.05	21.31	.76	28.57	12	168,735	75
AIB-12	19.050	38.10	17.45	22.23	24.84	.76	33.32	10	216,493	114
AIB-14	22.225	41.28	19.05	22.23	26.95	.89	34.93	6	260,889	159
* AIB-16	25.400	53.97	25.40	34.92	32.38	1.52	47.62	15	400,320	358

Studs available per notes and comments, page 76  
For suggested housing bores, see page 110

timkenaurorabearing.com • Fax 630-859-0971



# SIB SERIES

Spherical Bearings (PTFE Liners Available)<sup>1</sup>

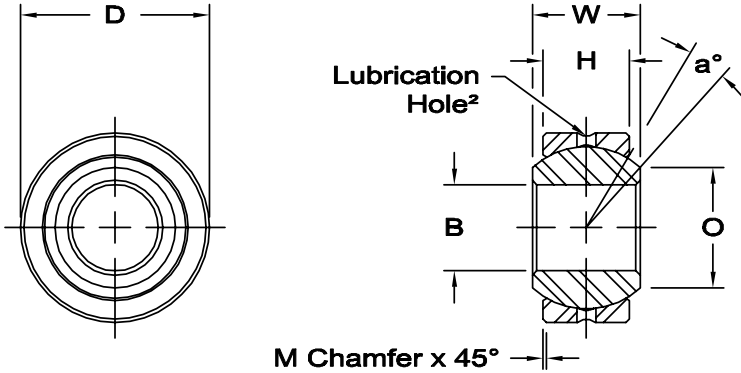

**Race** - Stainless steel, heat treated.

**Ball** - Alloy steel, heat treated, hard chrome plated.

**Notes** - All sizes available with studs upon request.



\*Bore Tolerance on these items is as follows -  
INCH: +.0035, -.0005; METRIC: +.089, -.103

\*\*Check for availability

<sup>1</sup> PTFE Liners use suffix T Ex: SIB-6T

<sup>2</sup> PTFE Lined parts have no lubrication groove in race. Hole manufactures option.

BEARING NO.	DIMENSIONS IN INCHES							a° Misalign. Angle	Radial Static Limit Load Capacity Lbs.	Approx. Brg. Wt. Lbs.
	B +.0015 -.0005	D +.0000 -.0007	H ± .005	W +.000 -.005	O Flat Dia. Ref.	M Chamfer Ref.	Ball Dia. Ref.			
** SIB-2	.1250	.4062	.187	.250	.187	.025	.312	17	4,110	.02
SIB-3	.1900	.5312	.250	.312	.307	.020	.437	10.5	6,555	.02
SIB-4	.2500	.6094	.281	.375	.331	.020	.500	14.5	8,430	.02
SIB-5	.3125	.7500	.344	.437	.448	.020	.625	11	12,900	.04
SIB-6	.3750	.8437	.406	.500	.516	.020	.719	9.5	17,516	.06
SIB-7	.4375	1.0000	.437	.562	.587	.020	.812	11	21,291	.08
SIB-8	.5000	1.0937	.500	.625	.699	.020	.937	9.5	28,110	.11
SIB-10	.6250	1.3125	.562	.750	.839	.030	1.125	12	37,935	.17
SIB-12	.7500	1.5000	.687	.875	.978	.030	1.312	10	48,672	.25
SIB-14	.8750	1.6250	.750	.875	1.061	.035	1.375	6	58,653	.35
* SIB-16	1.0000	2.1250	1.000	1.375	1.275	.060	1.875	15	90,000	.79

BEARING NO.	DIMENSIONS IN MILLIMETERS							a° Misalign. Angle	Radial Static Limit Load Capacity Newtons	Approx. Brg. Wt. Grams
	B +.038 -.013	D +.000 -.013	H ± .13	W +.00 -.13	O Flat Dia. Ref.	M Chamfer Ref.	Ball Dia. Ref.			
** SIB-2	3.175	10.31	4.74	6.35	4.74	.63	7.92	17	18,281	7
SIB-3	4.826	13.49	6.35	7.92	7.79	.50	11.10	10.5	29,157	7
SIB-4	6.350	15.47	7.13	9.52	8.40	.50	12.70	14.5	37,497	10
SIB-5	7.938	19.05	8.73	11.10	11.37	.50	15.87	11	57,379	18
SIB-6	9.525	21.43	10.31	12.70	13.10	.50	18.26	9.5	77,911	27
SIB-7	11.113	25.40	11.10	14.27	14.91	.50	20.62	11	94,702	36
SIB-8	12.700	27.78	12.70	15.87	17.75	.50	23.80	9.5	125,033	50
SIB-10	15.875	33.33	14.27	19.05	21.31	.76	28.57	12	168,735	75
SIB-12	19.050	38.10	17.45	22.23	24.84	.76	33.32	10	216,493	114
SIB-14	22.225	41.28	19.05	22.23	26.95	.89	34.93	6	260,889	159
* SIB-16	25.400	53.97	25.40	34.92	32.38	1.52	47.62	15	400,320	358

Studs available per notes and comments, page 76  
For suggested housing bores, see page 110



# HIGH MISALIGNMENT SERIES SPHERICAL BEARINGS



**Race** - 17-4 PH stainless steel, heat treated

**Ball** - Alloy steel, heat treated, hard chrome plated.

**PTFE liner** - (AT 3200)  
Permanently bonded to race inside diameter.

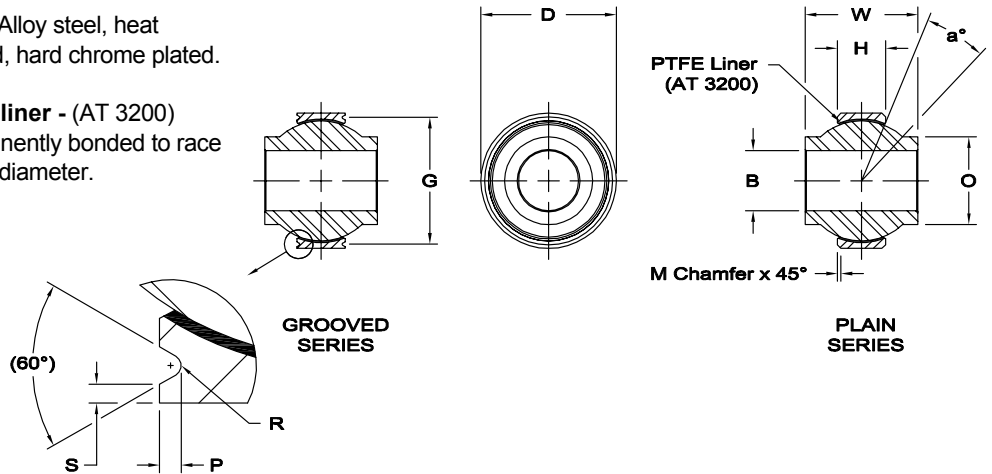

FOR STAKING INFORMATION, SEE PAGES 115-117.

BEARING NO.		DIMENSIONS IN INCHES											a° Misalign. Angle	Radial Static Limit Load Capacity Lbs.	Approx. Brg. Wt. Lbs.
Grooved	Plain	B + .0000 - .0005	D + .0000 - .0005	W + .000 - .005	H ± .005	M Ref.	O Ref.	P + .000 - .010	S Min.	G + .000 - .008	R + .002 - .005	Ball Dia. Ref.			
HAB-3TG	HAB-3T	.1900	.5625	.500	.210	.020	.317	.025	.010	.494	.010	.437	17	6,334	.02
HAB-4TG	HAB-4T	.2500	.7400	.593	.255	.020	.390	.025	.010	.674	.010	.593	24	7,560	.04
HAB-5TG-3	HAB-5T-3	.3125	.6875	.625	.255	.020	.418	.025	.010	.629	.010	.593	20	15,033	.03
HAB-5TG	HAB-5T	.3125	.9060	.813	.345	.030	.512	.025	.010	.840	.010	.781	23	16,975	.08
HAB-6TG	HAB-6T	.3750	.9060	.813	.345	.030	.512	.025	.010	.840	.010	.781	23	16,975	.07
HAB-7TG	HAB-7T	.4375	1.0000	.875	.345	.030	.618	.025	.010	.934	.010	.875	22	19,018	.09
HAB-8TG	HAB-8T	.5000	1.1250	.937	.401	.030	.730	.025	.010	1.059	.010	1.000	20	25,263	.13
HAB-10TG	HAB-10T	.6250	1.3750	1.200	.567	.030	.856	.035	.020	1.279	.015	1.250	20	44,651	.25
HAB-12TG	HAB-12T	.7500	1.5625	1.280	.620	.035	.970	.035	.020	1.467	.015	1.375	18	53,707	.33
HAB-14TG	HAB-14T	.8750	1.7500	1.400	.630	.039	1.140	.035	.020	1.654	.015	1.531	18	72,424	.44

timkenaurorabearing.com • Fax 630-859-0971



# PERFORMANCE RACING SERIES

PNB-TG & PNB-T Narrow Series Spherical Bearings - PTFE Lined

timkenaurorabearing.com • Fax 630-859-0971

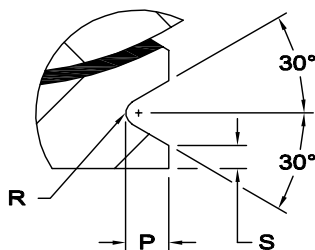
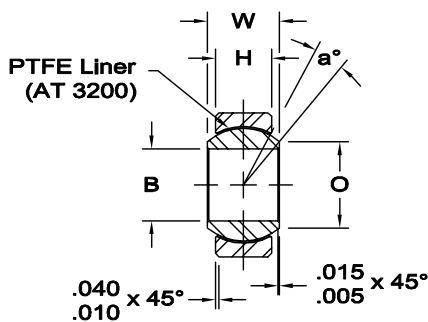
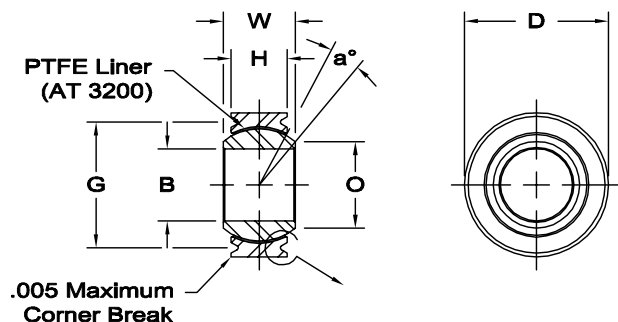

**Race** - 17-4 PH stainless steel, heat treated

**Ball** - Alloy steel, heat treated, hard chrome plated. Manufacturers option: 440C stainless steel, heat treated.

**PTFE Liner** - (AT 3200)  
Permanently bonded to race inside diameter.

FOR STAKING INFORMATION, SEE PAGES 115-117.

BEARING NO.		DIMENSIONS IN INCHES										a° Misalign. Angle	Static Limit Load		No Load Rotational Breakaway Torque In.-Lbs.	Approx. Brg. Wt. Lbs.
Grooved	Plain	B	D	W	H	O	P	S	G	R	Ball Dia. Ref.		Radial Lbs.	Axial Lbs.		
PNB-3TG	PNB-3T	.1900	.5625	.281	.218	.293	.025	.010	.500	.010	.406	10	3,975	150	0.25 - 5.0	.02
PNB-4TG	PNB-4T	.2500	.6562	.343	.250	.364	.025	.010	.594	.010	.500	10	6,040	430	0.25 - 5.0	.02
PNB-5TG	PNB-5T	.3125	.7500	.375	.281	.419	.035	.020	.650	.010	.562	10	8,750	700	0.25 - 8.0	.03
PNB-6TG	PNB-6T	.3750	.8125	.406	.312	.475	.035	.020	.712	.015	.625	9	10,540	1,100	0.25 - 8.0	.04
PNB-7TG	PNB-7T	.4375	.9062	.437	.343	.530	.035	.020	.806	.015	.687	8	13,200	1,400	0.25 - 8.0	.05
PNB-8TG	PNB-8T	.5000	1.0000	.500	.390	.600	.055	.020	.876	.015	.781	8	17,900	2,100	0.25 - 8.0	.07
PNB-9TG	PNB-9T	.5625	1.0937	.562	.437	.670	.060	.020	.972	.015	.875	8	23,200	3,680	0.25 - 8.0	.09
PNB-10TG	PNB-10T	.6250	1.1875	.625	.500	.739	.055	.020	1.063	.015	.968	8	30,500	4,720	0.25 - 8.0	.12
PNB-12TG	PNB-12T	.7500	1.4375	.750	.593	.920	.055	.020	1.313	.015	1.187	8	46,400	6,750	0.25 - 8.0	.21



**Race** - 17-4 PH stainless steel, heat treated

**Ball** - Alloy steel, heat treated, hard chrome plated. Manufacturers option: 440C stainless steel, heat treated.

**PTFE Liner** - (AT 3200)  
Permanently bonded to race inside diameter.

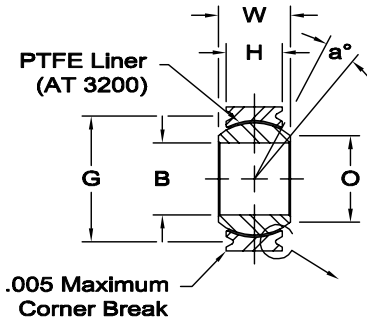

### GROOVED SERIES

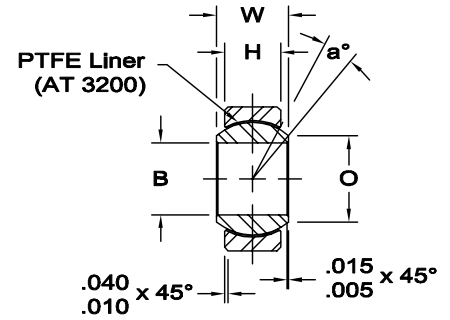
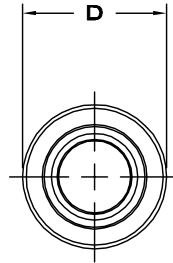

### PLAIN SERIES

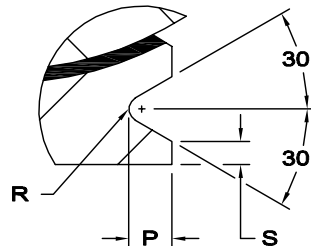

FOR STAKING INFORMATION, SEE PAGES 115-117.

BEARING NO.		DIMENSIONS IN INCHES										a° Misalign. Angle	Static Limit Load		No Load Rotational Breakaway Torque In.-Lbs.	Approx. Brg. Wt. Lbs.
Grooved	Plain	B +.0000 -.0005	D +.0000 -.0005	W +.000 -.005	H ±.005	O Min.	P +.000 -.010	S Min.	G +.000 -.008	R +.002 -.005	Ball Dia. Ref.		Radial Lbs.	Axial Lbs.		
PWB-3TG	PWB-3T	.1900	.6250	.437	.327	.300	.025	.010	.563	.010	.531	15	2,500	1,770	.25 - 5.0	.03
PWB-4TG	PWB-4T	.2500	.6250	.437	.327	.300	.025	.010	.563	.010	.531	15	5,500	1,770	.25 - 5.0	.03
PWB-5TG	PWB-5T	.3125	.6875	.437	.317	.360	.025	.010	.625	.010	.593	14	9,400	1,640	.25 - 8.0	.04
PWB-6TG	PWB-6T	.3750	.8125	.500	.406	.466	.035	.020	.712	.015	.687	8	13,700	2,630	.25 - 8.0	.06
PWB-7TG	PWB-7T	.4375	.9375	.562	.442	.537	.035	.020	.837	.015	.781	10	20,700	3,650	.25 - 8.0	.08
PWB-8TG	PWB-8T	.5000	1.0000	.625	.505	.607	.035	.020	.900	.015	.875	9	21,400	4,970	.25 - 8.0	.10
PWB-9TG	PWB-9T	.5625	1.1250	.687	.536	.721	.040	.020	1.025	.015	1.000	10	26,600	5,370	.25 - 8.0	.14
PWB-10TG	PWB-10T	.6250	1.1875	.750	.567	.747	.035	.020	1.087	.015	1.062	12	29,000	6,130	.25 - 8.0	.16
PWB-12TG	PWB-12T	.7500	1.3750	.875	.630	.845	.055	.020	1.251	.015	1.250	13	37,000	7,730	.25 - 8.0	.24



# CM-M & CB-M SERIES MALE ROD ENDS - METRIC

General Purpose – Economy

timkenaurorabearing.com • Fax 630-859-0971

METRIC

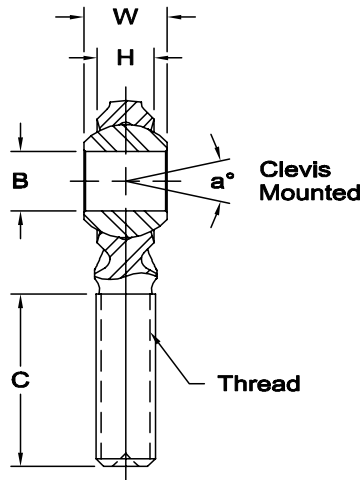
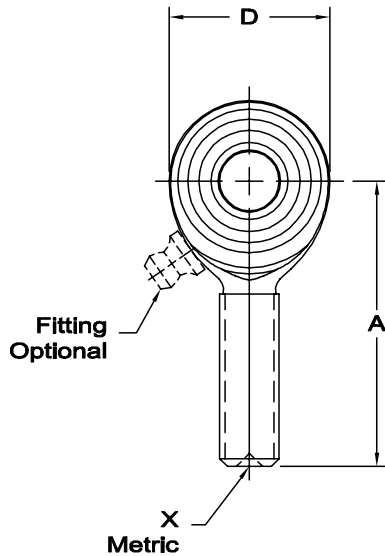

**Body** - Low carbon steel, protective coated for corrosion resistance.

**Ball** - Alloy steel, heat treated, hard chrome plated.

\*Check for availability. \*\* See page 5.  
X Designates metric threads.

Z Zerk type fitting - CM-M10Z  
(Not available for 3, 5, 6, & 8).

ROD END NO.		DIMENSIONS IN MILLIMETERS								a° Misalign. Angle**			Ultimate Radial Static Load Capacity Newtons	Approx. Brg. Wt. Grams	
Right Hand	Left Hand	B + .065 - .013	W ± .13	H Ref.	A ± .40	D Ref.	Ball Dia. Ref.	C ± 1.00	Thread	a <sub>1</sub>	a <sub>2</sub>	a <sub>3</sub>			
*	CM-M3	CB-M3	3	6	4.25	27	12.50	7.93	15	M3 X 0.5	23	34	71	1,775	7
	CM-M5	CB-M5	5	8	5.75	33	16.00	11.10	20	M5 X 0.8	22	30	64	5,168	12
	CM-M6	CB-M6	6	9	6.25	36	19.00	12.70	22	M6 X 1.0	23	31	65	7,296	18
	CM-M8	CB-M8	8	12	8.00	42	22.25	15.88	25	M8 X 1.25	28	38	59	13,591	31
	CM-M10	CB-M10	10	14	9.50	48	27.00	19.05	29	M10 X 1.5	26	35	57	21,024	68
	CM-M12	CB-M12	12	16	10.75	54	30.00	22.23	33	M12 X 1.75	27	34	57	25,819	78
*	CM-M14	CB-M14	14	19	12.25	60	34.75	25.40	36	M14 X 2.0	30	39	55	35,214	118
	CM-M16	CB-M16	16	21	12.75	66	38.00	28.58	40	M16 X 2.0	33	42	59	37,391	173
*	CM-M18	CB-M18	18	23	14.75	72	42.00	31.75	44	M18 X 1.5	30	37	56	47,903	260
	CM-M20	CB-M20	20	25	16.25	78	46.00	34.93	47	M20 X 1.5	29	36	55	57,101	290

# CW-M & CG-M SERIES FEMALE ROD ENDS - METRIC

General Purpose - Economy



**Body** - Low carbon steel, protective coated for corrosion resistance.

**Ball** - Alloy steel, heat treated, hard chrome plated.

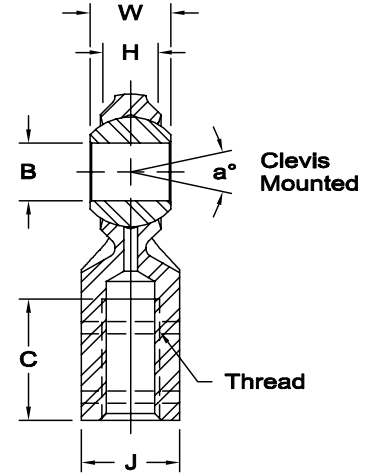
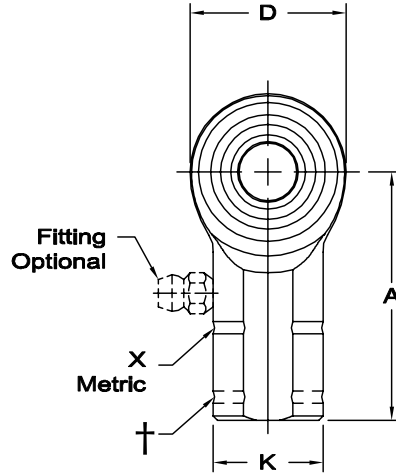

\*Check for availability. \*\* See page 5.  
X Designates metric threads.

Z Zerk type fitting - CW-M10Z  
(Not available for 3 & 5)

†Left hand units have identification groove near the end of shank.

ROD END NO.		DIMENSIONS IN MILLIMETERS										a°			Ultimate Radial Static Load Capacity Newtons	Approx. Brg. Wt. Grams
Right Hand	Left Hand†	B + .065 - .013	W ± .13	H Ref.	A ± .40	D Ref.	K ± .25	J ± .25	Ball Dia. Ref.	C ± 1.00	Thread	Misalign. Angle**				
												a <sub>1</sub>	a <sub>3</sub>	a <sub>4</sub>		
* CW-M3	CG-M3	3	6	4.25	21	12.50	8	7	7.93	10	M3 X 0.5	23	34	71	5,746	10
* CW-M5	CG-M5	5	8	5.75	27	16.00	11	9	11.10	14	M5 X 0.8	22	30	64	8,247	18
CW-M6	CG-M6	6	9	6.25	30	19.00	13	11	12.70	14	M6 X 1.0	23	31	65	11,895	25
CW-M8	CG-M8	8	12	8.00	36	22.25	16	14	15.88	17	M8 X 1.25	28	38	59	15,190	40
CW-M10	CG-M10	10	14	9.50	43	27.00	19	17	19.05	21	M10 X 1.5	26	35	57	22,750	80
CW-M12	CG-M12	12	16	10.75	50	30.00	22	19	22.23	24	M12 X 1.75	27	34	57	25,819	95
* CW-M14	CG-M14	14	19	12.25	57	34.75	25	22	25.40	27	M14 X 2.0	30	39	55	35,214	160
CW-M16	CG-M16	16	21	12.75	64	38.00	27	22	28.58	33	M16 X 2.0	33	42	59	37,391	215
* CW-M18	CG-M18	18	23	14.75	71	42.00	31	27	31.75	36	M18 X 1.5	30	37	56	47,903	300
CW-M20	CG-M20	20	25	16.25	77	46.00	34	30	34.93	40	M20 X 1.5	29	36	55	57,101	350

timkenaurorabearing.com • Fax 630-859-0971

METRIC



# MM-M & MB-M SERIES MALE ROD ENDS - METRIC

General Purpose – Precision (PTFE Liners Available)

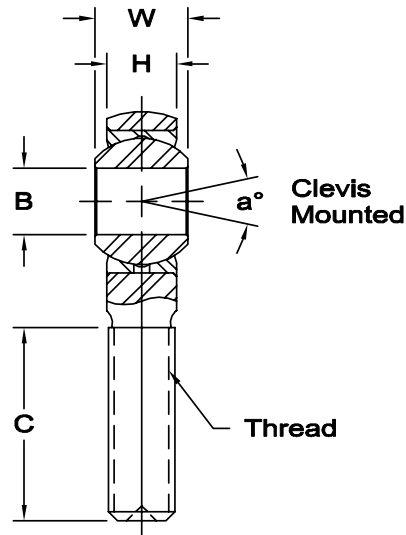
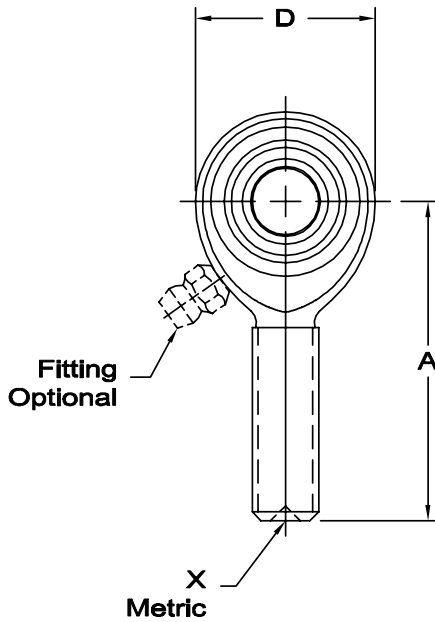

**Body** - Low carbon steel, protective coated for corrosion resistance.

**Race** - Low carbon steel, protective coated for corrosion resistance.

**Ball** - Alloy steel, heat treated, hard chrome plated.

timkenaurorabearing.com • Fax 630-859-0971

METRIC

\*Check for availability.

\*\* See page 5.

X Designates metric threads.

1 Tolerance variation: "D" ± .51, "A" ± .51

‡ Grease fitting not available on this size. Units are supplied without grease fittings. When a grease fitting is required, specify by adding suffix as designated.

Z Zerk type fitting

Ex: MM-M10Z

F Flush type fitting

Ex: MM-M10F

T PTFE Liner

Ex: MM-M10T

Load ratings apply only to rod ends without grease fittings. For load ratings with fittings, please consult our engineering department.

ROD END NO.		DIMENSIONS IN MILLIMETERS								a°			Ultimate Radial Static Load Capacity Newtons	Approx. Brg. Wt. Grams	
Right Hand	Left Hand	B +.065 -.013	W ±.13	H ±.13	A ±.40	D ±.38	Ball Dia. Ref.	C ± 1.00	Thread	Misalign. Angle**	a <sub>1</sub>	a <sub>2</sub>			a <sub>3</sub>
*	‡MM-M3	‡MB-M3	3	6	4.75	27	12.50	7.93	15	M3 X 0.5	13	25	62	1,775	7
	MM-M5	MB-M5	5	8	6.25	33	16.00	11.10	20	M5 X 0.8	14	24	58	5,168	13
	MM-M6	MB-M6	6	9	7.00	36	19.00	12.70	22	M6 X 1.0	13	23	57	7,296	18
	MMF-M8	MBF-M8	8	12	8.75	42	22.25	15.88	25	M8 X 1.0	18	31	53	13,591	31
	MM-M8	MB-M8	8	12	8.75	42	22.25	15.88	25	M8 X 1.25	18	31	53	13,591	31
	MMF-M10	MBF-M10	10	14	10.50	48	27.00	19.05	29	M10 X 1.25	17	28	50	20,603	68
	MM-M10	MB-M10	10	14	10.50	48	27.00	19.05	29	M10 X 1.5	17	28	50	20,603	68
	MMF-M12	MBF-M12	12	16	12.00	54	30.00	22.23	33	M12 X 1.25	17	27	49	18,215	78
	MM-M12	MB-M12	12	16	12.00	54	30.00	22.23	33	M12 X 1.75	17	27	49	18,215	78
	MMF-M14	MBF-M14	14	19	13.50	60	34.75	25.40	36	M14 X 1.5	21	33	49	29,840	118
	MM-M14	MB-M14	14	19	13.50	60	34.75	25.40	36	M14 X 2.0	21	33	49	29,840	118
	MMF-M16	MBF-M16	16	21	14.25	66	38.00	28.58	40	M16 X 1.5	23	35	52	32,223	173
	MM-M16	MB-M16	16	21	14.25	66	38.00	28.58	40	M16 X 2.0	23	35	52	32,223	173
*	MM-M18	MB-M18	18	23	16.25	72	42.00	31.75	44	M18 X 1.5	21	31	49	41,303	260
	MMF-M20	MBF-M20	20	25	18.00	78	46.00	34.93	47	M20 X 1.5	20	29	48	50,952	290
	MM-M20	MB-M20	20	25	18.00	78	46.00	34.93	47	M20 X 2.5	20	29	48	50,952	290
*	MM-M22	MB-M22	22	28	19.50	86	50.00	38.10	51	M22 X 1.5	22	33	48	56,238	315
	MM-M25	MB-M25	25	31	22.00	95	60.00	42.86	57	M24 X 2.0	19	31	47	104,435	500
1	MM-M30	MB-M30	30	37	25.40	104.78	69.85	50.80	60	M30 X 2.0	21	33	47	147,238	1,090

# MW-M & MG-M SERIES FEMALE ROD ENDS - METRIC

General Purpose – Precision (PTFE Liners Available)



**Body** - Low carbon steel, protective coated for corrosion resistance.

**Race** - Low carbon steel, protective coated for corrosion resistance.

**Ball** - Alloy steel, heat treated, hard chrome plated.

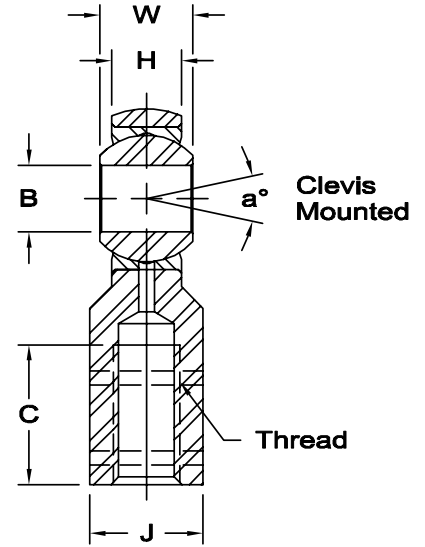
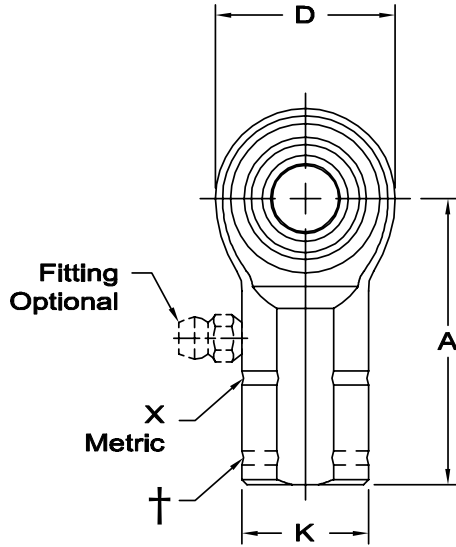

\* Check for availability.

\*\* See page 5.

X Designates metric threads.

† Left hand units have identification groove.

1 Tolerance variation: "D" ± .51, "A" ± .51

‡ Grease fitting not available on this size. Units are supplied without grease fittings. When a grease fitting is required, specify by adding suffix as designated.

Z Zerk type fitting Ex: MW-M10Z  
 F Flush type fitting Ex: MW-M10F  
 T PTFE Liner Ex: MW-M10T

timkenaurorabearing.com • Fax 630-859-0971

METRIC

ROD END NO.		DIMENSIONS IN MILLIMETERS											a°			Ultimate Radial Static Load Capacity Newtons	Approx. Brg. Wt. Grams
Right Hand	Left Hand†	B + .065 - .013	W ± .13	H ± .13	A ± .40	D ± .38	K ± .25	J ± .25	Ball Dia. Ref.	C ± 1.00	Thread	Misalign. Angle**					
												a <sub>1</sub>	a <sub>2</sub>	a <sub>3</sub>			
‡MW-M3	‡MG-M3	3	6	4.75	21	12.50	8	7	7.93	10	M3 X 0.5	13	25	62	4,972	10	
MW-M5	MG-M5	5	8	6.25	27	16.00	11	9	11.10	14	M5 X 0.8	14	24	58	7,090	17	
MW-M6	MG-M6	6	9	7.00	30	19.00	13	11	12.70	14	M6 X 1.0	13	23	57	10,573	25	
MWF-M8	MGF-M8	8	12	8.75	36	22.25	16	14	15.88	17	M8 X 1.0	18	31	53	14,072	40	
MW-M8	MG-M8	8	12	8.75	36	22.25	16	14	15.88	17	M8 X 1.25	18	31	53	14,072	40	
MWF-M10	MGF-M10	10	14	10.50	43	27.00	19	17	19.05	21	M10 X 1.25	17	28	50	20,603	80	
MW-M10	MG-M10	10	14	10.50	43	27.00	19	17	19.05	21	M10 X 1.5	17	28	50	20,603	80	
MWF-M12	MGF-M12	12	16	12.00	50	30.00	22	19	22.23	24	M12 X 1.25	17	27	49	18,215	95	
MW-M12	MG-M12	12	16	12.00	50	30.00	22	19	22.23	24	M12 X 1.75	17	27	49	18,215	95	
MWF-M14	MGF-M14	14	19	13.50	57	34.75	25	22	25.40	27	M14 X 1.5	21	33	49	29,840	160	
MW-M14	MG-M14	14	19	13.50	57	34.75	25	22	25.40	27	M14 X 2.0	21	33	49	29,840	160	
MWF-M16	MGF-M16	16	21	14.25	64	38.00	27	22	28.58	33	M16 X 1.5	23	35	52	32,223	215	
MW-M16	MG-M16	16	21	14.25	64	38.00	27	22	28.58	33	M16 X 2.0	23	35	52	32,223	215	
MW-M18	MG-M18	18	23	16.25	71	42.00	31	27	31.75	36	M18 X 1.5	21	31	49	41,303	300	
MWF-M20	MGF-M20	20	25	18.00	77	46.00	34	30	34.93	40	M20 X 1.5	20	29	48	50,952	350	
MW-M20	MG-M20	20	25	18.00	77	46.00	34	30	34.93	40	M20 X 2.5	20	29	48	50,952	350	
* MW-M22	MG-M22	22	28	19.50	86	50.00	37	32	38.10	43	M22 X 1.5	22	33	48	56,238	390	
MW-M25	MG-M25	25	31	22.00	95	60.00	42	36	42.86	48	M24 X 2.0	19	31	47	104,435	700	
1 MW-M30	MG-M30	30	37	25.40	104.78	69.85	41.25	38.10	50.80	54	M30 X 2.0	21	33	47	147,238	970	



# KM-M & KB-M SERIES MALE ROD ENDS - METRIC

Wear Resistant – Precision

timkenaurorabearing.com • Fax 630-859-0971

METRIC

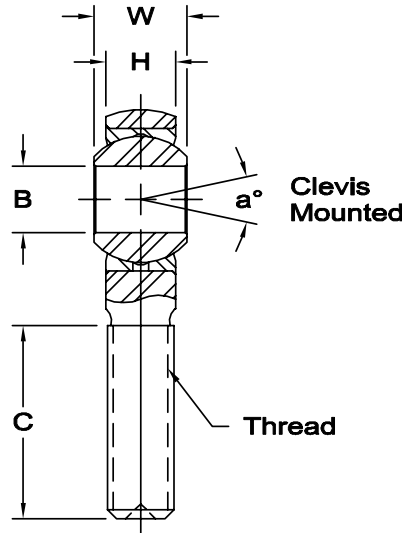
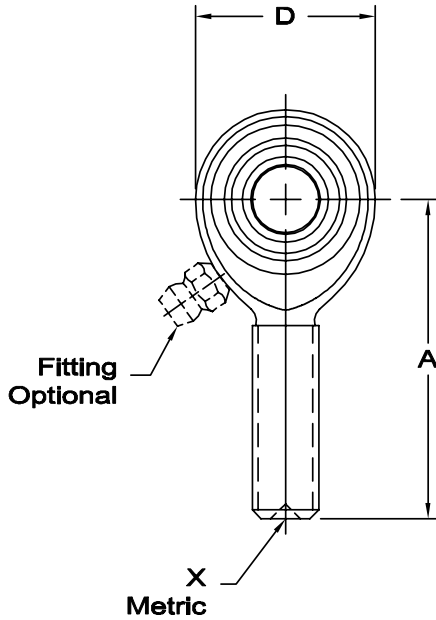

**Body** - Low carbon steel, protective coated for corrosion resistance.

**Race** - Alloy steel, heat treated, protective coated for corrosion resistance.

**Ball** - Alloy steel, heat treated, hard chrome plated.

\*Check for availability.

\*\* See page 5.

X Designates metric threads.

1 Tolerance variation: "D" ± .51, "A" ± .51

‡ Grease fitting not available on this size. Units are supplied without grease fittings. When a grease fitting is required, specify by adding suffix as designated.

Z Zerk type fitting

Ex: KM-M10Z

F Flush type fitting

Ex: KM-M10F

Load ratings apply only to rod ends without grease fittings. For load ratings with fittings, please consult our engineering department.

ROD END NO.		DIMENSIONS IN MILLIMETERS								a°			Ultimate Radial Static Load Capacity Newtons	Approx. Brg. Wt. Grams	
Right Hand	Left Hand	B + .065 - .013	W ± .13	H ± .13	A ± .40	D ± .38	Ball Dia. Ref.	C ± 1.00	Thread	Misalign. Angle**					
										a <sub>1</sub>	a <sub>2</sub>	a <sub>3</sub>			
* ‡	KM-M3	‡KB-M3	3	6	4.75	27	12.50	7.93	15	M3 X 0.5	13	25	62	1,775	7
	KM-M5	KB-M5	5	8	6.25	33	16.00	11.10	20	M5 X 0.8	14	24	58	5,168	13
	KM-M6	KB-M6	6	9	7.00	36	19.00	12.70	22	M6 X 1.0	13	23	57	7,296	18
	KMF-M8	KBF-M8	8	12	8.75	42	22.25	15.88	25	M8 X 1.0	18	31	53	13,591	31
	KM-M8	KB-M8	8	12	8.75	42	22.25	15.88	25	M8 X 1.25	18	31	53	13,591	31
	KMF-M10	KBF-M10	10	14	10.50	48	27.00	19.05	29	M10 X 1.25	17	28	50	20,603	68
	KM-M10	KB-M10	10	14	10.50	48	27.00	19.05	29	M10 X 1.5	17	28	50	20,603	68
	KMF-M12	KBF-M12	12	16	12.00	54	30.00	22.23	33	M12 X 1.25	17	27	49	18,215	78
	KM-M12	KB-M12	12	16	12.00	54	30.00	22.23	33	M12 X 1.75	17	27	49	18,215	78
	KMF-M14	KBF-M14	14	19	13.50	60	34.75	25.40	36	M14 X 1.5	21	33	49	29,840	118
* ‡	KM-M14	KB-M14	14	19	13.50	60	34.75	25.40	36	M14 X 2.0	21	33	49	29,840	118
	KMF-M16	KBF-M16	16	21	14.25	66	38.00	28.58	40	M16 X 1.5	23	35	52	32,223	173
	KM-M16	KB-M16	16	21	14.25	66	38.00	28.58	40	M16 X 2.0	23	35	52	32,223	173
* ‡	KM-M18	KB-M18	18	23	16.25	72	42.00	31.75	44	M18 X 1.5	21	31	49	41,303	260
	KMF-M20	KBF-M20	20	25	18.00	78	46.00	34.93	47	M20 X 1.5	20	29	48	50,952	290
* ‡	KM-M20	KB-M20	20	25	18.00	78	46.00	34.93	47	M20 X 2.5	20	29	48	50,952	290
* ‡	KM-M22	KB-M22	22	28	19.50	86	50.00	38.10	51	M22 X 1.5	22	33	48	56,238	315
* ‡	KM-M25	KB-M25	25	31	22.00	95	60.00	42.86	57	M24 X 2.0	19	31	47	104,435	500
1* ‡	KM-M30	KB-M30	30	37	25.40	104.78	69.85	50.80	60	M30 X 2.0	21	33	47	147,238	1,090



# KW-M & KG-M SERIES FEMALE ROD ENDS - METRIC

Wear Resistant – Precision



**Body** - Low carbon steel, protective coated for corrosion resistance.

**Race** - Alloy steel, heat treated, protective coated for corrosion resistance.

**Ball** - Alloy steel, heat treated, hard chrome plated.

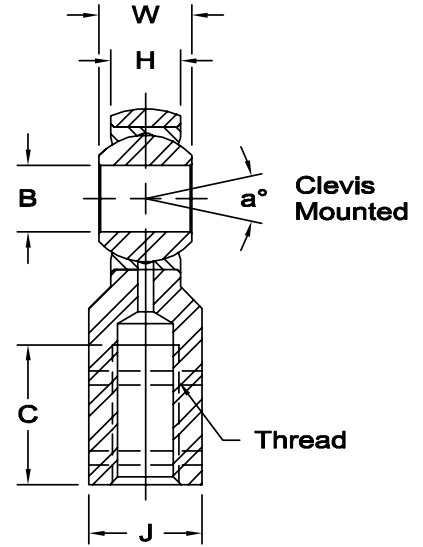
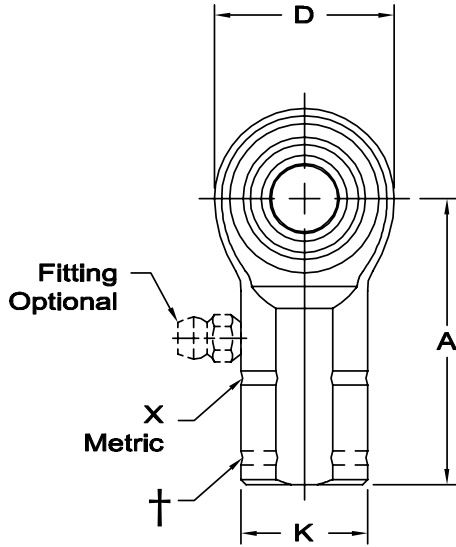

\* Check for availability.

\*\* See page 5.

X Designates metric threads.

† Left hand units have identification groove.

1 Tolerance variation: "D" ± .51, "A" ± .51

‡ Grease fitting not available on this size. Units are supplied without grease fittings. When a grease fitting is required, specify by adding suffix as designated.

Z Zerk type fitting Ex: KW-M10Z

F Flush type fitting Ex: KW-M10F

ROD END NO.		DIMENSIONS IN MILLIMETERS											a°			Ultimate Radial Static Load Capacity Newtons	Approx. Brg. Wt. Grams
Right Hand	Left Hand†	B + .065 - .013	W ± .13	H ± .13	A ± .40	D ± .38	K ± .25	J ± .25	Ball Dia. Ref.	C ± 1.00	Thread	Misalign. Angle**					
												a <sub>1</sub>	a <sub>2</sub>	a <sub>3</sub>			
*	‡KW-M3	‡KG-M3	3	6	4.75	21	12.50	8	7	7.93	10	M3 X 0.5	13	25	62	4,972	10
	KW-M5	KG-M5	5	8	6.25	27	16.00	11	9	11.10	14	M5 X 0.8	14	24	58	7,090	17
	KW-M6	KG-M6	6	9	7.00	30	19.00	13	11	12.70	14	M6 X 1.0	13	23	57	10,573	25
	KWF-M8	KGf-M8	8	12	8.75	36	22.25	16	14	15.88	17	M8 X 1.0	18	31	53	14,072	40
	KW-M8	KG-M8	8	12	8.75	36	22.25	16	14	15.88	17	M8 X 1.25	18	31	53	14,072	40
	KWF-M10	KGf-M10	10	14	10.50	43	27.00	19	17	19.05	21	M10 X 1.25	17	28	50	20,603	80
	KW-M10	KG-M10	10	14	10.50	43	27.00	19	17	19.05	21	M10 X 1.5	17	28	50	20,603	80
	KWF-M12	KGf-M12	12	16	12.00	50	30.00	22	19	22.23	24	M12 X 1.25	17	27	49	18,215	95
	KW-M12	KG-M12	12	16	12.00	50	30.00	22	19	22.23	24	M12 X 1.75	17	27	49	18,215	95
	KWF-M14	KGf-M14	14	19	13.50	57	34.75	25	22	25.40	27	M14 X 1.5	21	33	49	29,840	160
*	KW-M14	KG-M14	14	19	13.50	57	34.75	25	22	25.40	27	M14 X 2.0	21	33	49	29,840	160
	KWF-M16	KGf-M16	16	21	14.25	64	38.00	27	22	28.58	33	M16 X 1.5	23	35	52	32,223	215
	KW-M16	KG-M16	16	21	14.25	64	38.00	27	22	28.58	33	M16 X 2.0	23	35	52	32,223	215
*	KW-M18	KG-M18	18	23	16.25	71	42.00	31	27	31.75	36	M18 X 1.5	21	31	49	41,303	300
	KWF-M20	KGf-M20	20	25	18.00	77	46.00	34	30	34.93	40	M20 X 1.5	20	29	48	50,952	350
*	KW-M20	KG-M20	20	25	18.00	77	46.00	34	30	34.93	40	M20 X 2.5	20	29	48	50,952	350
*	KW-M22	KG-M22	22	28	19.50	86	50.00	37	32	38.10	43	M22 X 1.5	22	33	48	56,238	390
*	KW-M25	KG-M25	25	31	22.00	95	60.00	42	36	42.86	48	M24 X 2.0	19	31	47	104,435	700
1 *	KW-M30	KG-M30	30	37	25.40	104.78	69.85	41.25	38.10	50.80	54	M30 X 2.0	21	33	47	147,238	970



# AM-M & AB-M SERIES MALE ROD ENDS - METRIC

High Strength Alloy – Precision – (PTFE Liners Available)

timkenaurorabearing.com • Fax 630-859-0971

METRIC

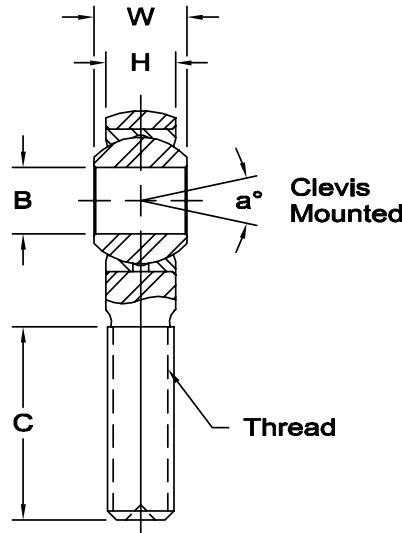
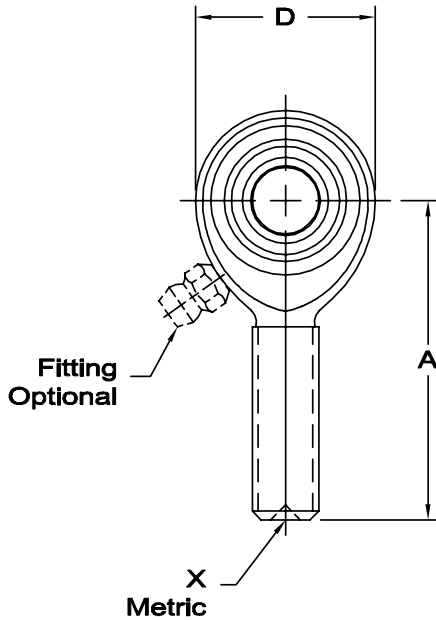

**Body** - Alloy steel, heat treated, protective coated for corrosion resistance.

**Race** - Alloy steel, heat treated, protective coated for corrosion resistance.

**Ball** - Alloy steel, heat treated, hard chrome plated.

\*Check for availability.

\*\* See page 5.

X Designates metric threads.

1 Tolerance variation: "D" ± .51, "A" ± .51

‡ Grease fitting not available on this size. Units are supplied without grease fittings. When a grease fitting is required, specify by adding suffix as designated.

Z Zerk type fitting

F Flush type fitting

T PTFE Liner

Ex: AM-M10Z

Ex: AM-M10F

Ex: AM-M10T

ROD END NO.		DIMENSIONS IN MILLIMETERS								a°			Ultimate Radial Static Load Capacity Newtons	Approx. Brg. Wt. Grams
Right Hand	Left Hand	B +.065 -.013	W ±.13	H ±.13	A ±.40	D ±.38	Ball Dia. Ref.	C ± 1.00	Thread	Misalign. Angle**	a <sub>1</sub>	a <sub>3</sub>		
‡AM-M3	‡AB-M3	3	6	4.75	27	12.50	7.93	15	M3 X 0.5	13	25	62	4,344	7
AM-M5	AB-M5	5	8	6.25	33	16.00	11.10	20	M5 X 0.8	14	24	58	12,611	13
AM-M6	AB-M6	6	9	7.00	36	19.00	12.70	22	M6 X 1.0	13	23	57	17,720	18
AMF-M8	ABF-M8	8	12	8.75	42	22.25	15.88	25	M8 X 1.0	18	31	53	33,135	31
AM-M8	AB-M8	8	12	8.75	42	22.25	15.88	25	M8 X 1.25	18	31	53	33,135	31
AMF-M10	ABF-M10	10	14	10.50	48	27.00	19.05	29	M10 X 1.25	17	28	50	50,227	68
AM-M10	AB-M10	10	14	10.50	48	27.00	19.05	29	M10 X 1.5	17	28	50	50,227	68
AMF-M12	ABF-M12	12	16	12.00	54	30.00	22.23	33	M12 X 1.25	17	27	49	44,490	78
AM-M12	AB-M12	12	16	12.00	54	30.00	22.23	33	M12 X 1.75	17	27	49	44,490	78
AMF-M14	ABF-M14	14	19	13.50	60	34.75	25.40	36	M14 X 1.5	21	33	49	71,741	118
AM-M14	AB-M14	14	19	13.50	60	34.75	25.40	36	M14 X 2.0	21	33	49	71,741	118
AMF-M16	ABF-M16	16	21	14.25	66	38.00	28.58	40	M16 X 1.5	23	35	52	76,291	173
AM-M16	AB-M16	16	21	14.25	66	38.00	28.58	40	M16 X 2.0	23	35	52	76,291	173
* AM-M18	AB-M18	18	23	16.25	72	42.00	31.75	44	M18 X 1.5	21	31	49	100,738	260
AMF-M20	ABF-M20	20	25	18.00	78	46.00	34.93	47	M20 X 1.5	20	29	48	120,212	290
AM-M20	AB-M20	20	25	18.00	78	46.00	34.93	47	M20 X 2.5	20	29	48	120,212	290
* AM-M22	AB-M22	22	28	19.50	86	50.00	38.10	51	M22 X 1.5	22	33	48	137,099	315
AM-M25	AB-M25	25	31	22.00	95	60.00	42.86	57	M24 X 2.0	19	31	47	251,780	500
1 AM-M30	AB-M30	30	37	25.40	104.78	69.85	50.80	60	M30 X 2.0	21	33	47	289,331	1,090

# AW-M & AG-M SERIES FEMALE ROD ENDS - METRIC

High Strength Alloy - Precision - (PTFE Liners Available)



timkenaurorabearing.com • Fax 630-859-0971

METRIC



**Body** - Alloy steel, heat treated, protective coated for corrosion resistance.

**Race** - Alloy steel, heat treated, protective coated for corrosion resistance.

**Ball** - Alloy steel, heat treated, hard chrome plated.

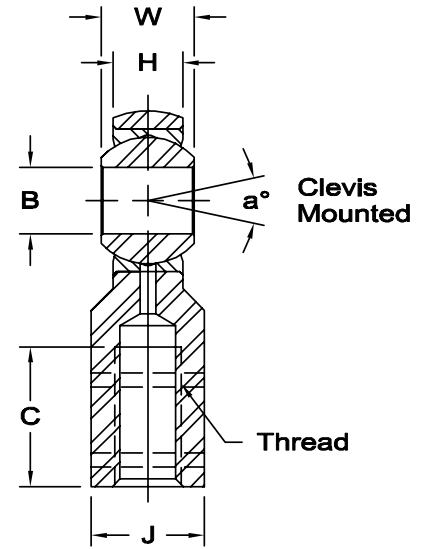
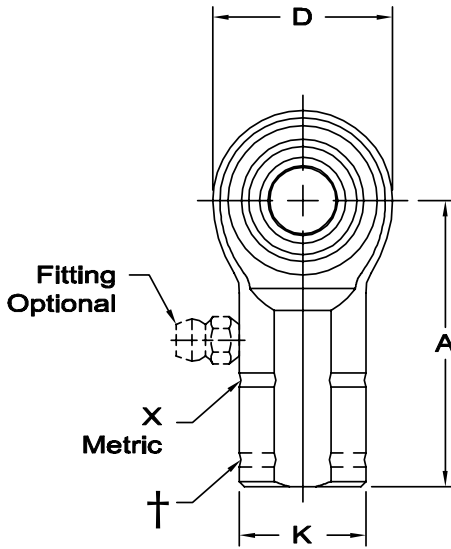

\*Check for availability.

\*\* See page 5.

† Left hand units have identification groove near end of shank

X Designates metric threads.

1 Tolerance variation: "D" ± .51, "A" ± .51

‡ Grease fitting not available on this size. Units are supplied without grease fittings. When a grease fitting is required, specify by adding suffix as designated.

Z Zerk type fitting

F Flush type fitting

T PTFE Liner

Ex: AW-M10Z

Ex: AW-M10F

Ex: AW-M10T

ROD END NO.		DIMENSIONS IN MILLIMETERS											a°			Ultimate Radial Static Load Capacity Newtons	Approx. Brg. Wt. Grams
Right Hand	Left Hand	B + .065 - .013	W ± .13	H ± .13	A ± .40	D ± .38	K ± .25	J ± .25	Ball Dia. Ref.	C ± 1.00	Thread	Misalign. Angle**					
												a <sub>1</sub>	a <sub>2</sub>	a <sub>3</sub>			
*	‡AW-M3	‡AG-M3	3	6	4.75	21	12.50	8	7	7.93	10	M3 X 0.5	13	25	62	11,346	10
	AW-M5	AG-M5	5	8	6.25	27	16.00	11	9	11.10	14	M5 X 0.8	14	24	58	16,396	17
	AW-M6	AG-M6	6	9	7.00	30	19.00	13	11	12.70	14	M6 X 1.0	13	23	57	25,781	25
	AWF-M8	AGF-M8	8	12	8.75	36	22.25	16	14	15.88	17	M8 X 1.0	18	31	53	33,203	40
	AW-M8	AG-M8	8	12	8.75	36	22.25	16	14	15.88	17	M8 X 1.25	18	31	53	33,203	40
	AWF-M10	AGF-M10	10	14	10.50	43	27.00	19	17	19.05	21	M10 X 1.25	17	28	50	50,227	80
	AW-M10	AG-M10	10	14	10.50	43	27.00	19	17	19.05	21	M10 X 1.5	17	28	50	50,227	80
	AWF-M12	AGF-M12	12	16	12.00	50	30.00	22	19	22.23	24	M12 X 1.25	17	27	49	44,490	95
	AW-M12	AG-M12	12	16	12.00	50	30.00	22	19	22.23	24	M12 X 1.75	17	27	49	44,490	95
	AWF-M14	AGF-M14	14	19	13.50	57	34.75	25	22	25.40	27	M14 X 1.5	21	33	49	71,741	160
	AW-M14	AG-M14	14	19	13.50	57	34.75	25	22	25.40	27	M14 X 2.0	21	33	49	71,741	160
	AWF-M16	AGF-M16	16	21	14.25	64	38.00	27	22	28.58	33	M16 X 1.5	23	35	52	76,291	215
	AW-M16	AG-M16	16	21	14.25	64	38.00	27	22	28.58	33	M16 X 2.0	23	35	52	76,291	215
*	AW-M18	AG-M18	18	23	16.25	71	42.00	31	27	31.75	36	M18 X 1.5	21	31	49	100,738	300
	AWF-M20	AGF-M20	20	25	18.00	77	46.00	34	30	34.93	40	M20 X 1.5	20	29	48	120,212	350
	AW-M20	AG-M20	20	25	18.00	77	46.00	34	30	34.93	40	M20 X 2.5	20	29	48	120,212	350
*	AW-M22	AG-M22	22	28	19.50	86	50.00	37	32	38.10	43	M22 X 1.5	22	33	48	137,099	390
	AW-M25	AG-M25	25	31	22.00	95	60.00	42	36	42.86	48	M24 X 2.0	19	31	47	251,780	700
1	AW-M30	AG-M30	30	37	25.40	104.78	69.85	41.25	38.10	50.80	54	M30 X 2.0	21	33	47	289,331	970



# COM-M SERIES SPHERICAL BEARINGS - METRIC

(PTFE Liners Available)<sup>1</sup>

timkenaurorabearing.com • Fax 630-859-0971

METRIC

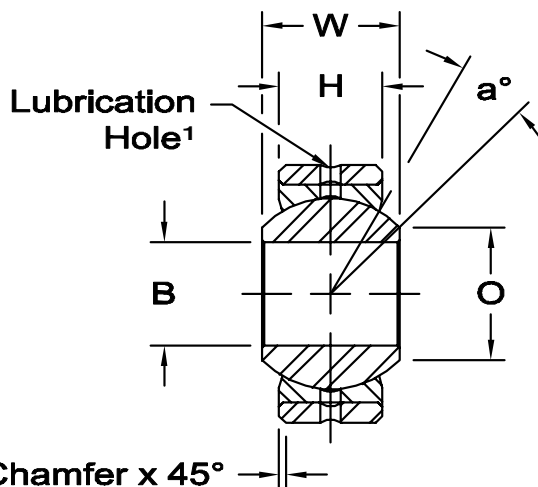
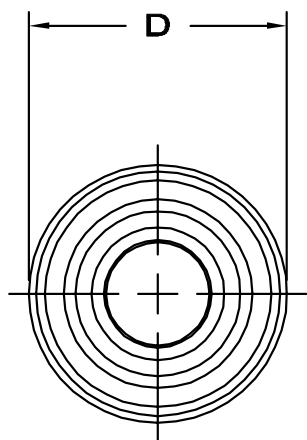

M Chamfer x 45°



**Outer Member** - Low carbon steel, protective coated for corrosion resistance.

**Race** - Low carbon steel, I.D. protective coated for corrosion resistance.

**Ball** - Alloy steel, heat treated, hard chrome plated.

\* Check for availability.

<sup>1</sup> PTFE Liners use suffix T Ex: COM-M10T. PTFE lined parts do not have lubrication groove in outer member.

<sup>2</sup> Based upon maximum permanent set of .5% of ball O.D. (See page 5)

‡ Size 16 consists of ball & race only

BEARING NO.	DIMENSIONS IN MILLIMETERS							a° Misalign. Angle	Radial Static Limit Load Capacity Newtons <sup>2</sup>	Approx. Brg. Wt. Grams
	B + .065 - .013	D + .000 - .018	H ± .13	W ± .13	O Flat Dia Ref.	M Chamfer Ref.	Ball Dia Ref.			
* COM-M3	3	12	4.50	6	5.19	.5	7.93	13.5	14,758	4
* COM-M5	5	16	6.00	8	7.68	.5	11.10	12.5	27,555	9
COM-M6	6	18	6.75	9	8.93	.5	12.70	12.5	35,459	13
COM-M8	8	22	9.00	12	10.35	.8	15.88	14	59,121	24
COM-M10	10	26	10.50	14	12.88	.8	19.05	13.5	82,744	40
COM-M12	12	30	12.00	16	15.39	.8	22.23	13	112,829	80
COM-M14	14	34	13.50	19	16.86	1.0	25.40	16	141,845	110
‡ COM-M16	16	38	15.00	21	19.34	1.0	28.58	15	177,343	130
* COM-M18	18	42	16.50	23	21.89	1.0	31.75	15	216,714	170
COM-M20	20	46	18.00	25	24.35	1.0	34.93	14.5	260,086	230
* COM-M22	22	50	20.00	28	25.84	1.5	38.10	15	315,216	280
* COM-M25	25	56	22.00	31	29.60	1.5	42.86	15	390,056	390
* COM-M30	30	66	25.00	37	34.81	1.5	50.80	17	525,360	610

For suggested housing bores, see page 111

# FRACTURED RACE\* BEARINGS

\*Also known as a split race bearings or light series bearings



timkenaurorabearing.com • Fax 630-859-0971

These types of bearings are first and foremost intended for static situations where potential misalignments exist that can not be accomodated by bushings or clevises and pins.

While these bearings are most commonly used in applications with heavy static loads with initial or assembly misalignment, they are also used for dynamic applications with slow dynamic misalignment, either pivotal, rotational, or combination. For dynamic applications subject to regular misalignment, a full swage bearing such as the COM series is recommended.



**GEZ..ES**  
**OPEN**

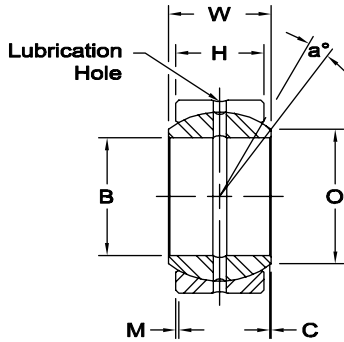

**GEZ..ES**  
**OPEN**

**GEZ..ES-2RS**  
**SEALED**

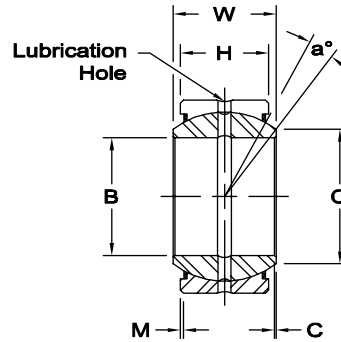

**GEZ..ES-2RS**  
**SEALED**



**Race** - 52100 steel, heat treated, protective coated for corrosion resistance.

**Ball** - 52100 steel, heat treated, protective coated for corrosion resistance.

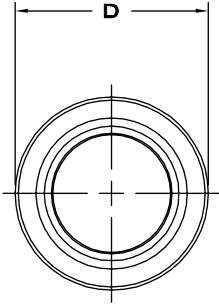

### RADIAL STATIC LOAD CAPACITY

These loads are the maximum safe operating loads for stationary applications, and assumes a sufficiently rigid housing and shaft. The radial static load capacity provides a 1.5 factor of safety against static fracture.

### LUBRICATION

Bearings should only be used as delivered for static applications. For dynamic applications, a lithium-based grease with EP and MOS<sub>2</sub> additives is especially suitable. Lubricants of this type are recommended for operating temperatures between -40° F and + 250° F (-40° C and +121° C). For operating temperatures outside of this range, consult lubricant manufacturer.

Bearings should be adequately lubricated before installation, and relubricated at suitable intervals based on application demands. Demand factors include load and load direction, misalignment angle and frequency, ambient temperature and contamination level.

The dimensions and tolerances apply before surface treatment and splitting of the outer race. The outer race can become slightly out of round due to splitting, but when the bearing is mounted into the bearing housing, the roundness of the outer race will be restored. The measured value of the bearing outside diameter without mounting is not to be used as the original actual value of the outside diameter.

BEARING NO.		DIMENSIONS IN INCHES											a° Misalign. Angle	Radial Static Limit Load Capacity Lbs.	Approx. Brg. Wt. Lbs.
OPEN	SEALED	B Bore Dia.		D Race Dia.		W Ball Width		H Race Width		O Flat Dia.	C Ball Cmf.	M Race Cmf.			
		Max.	Min.	Max.	Min.	Max.	Min.	Max.	Min.	Min.	Min.	Min.			
GEZ008ES		.5000	.4995	.8750	.8745	.437	.432	.375	.365	.555	.006	.024	6	9,217	.05
GEZ010ES		.6250	.6245	1.0625	1.0620	.547	.542	.469	.459	.720	.006	.024	6	14,612	.08
GEZ012ES	GEZ012ES-2RS	.7500	.7495	1.2500	1.2495	.656	.651	.562	.552	.858	.012	.024	6	21,356	.12
GEZ014ES	GEZ014ES-2RS	.8750	.8745	1.4375	1.4370	.765	.760	.656	.646	1.000	.012	.024	6	28,550	.19
GEZ016ES	GEZ016ES-2RS	1.0000	.9995	1.6250	1.6245	.875	.870	.750	.740	1.087	.012	.024	6	37,317	.27
GEZ020ES	GEZ020ES-2RS	1.2500	1.2495	2.0000	1.9995	1.093	1.088	.937	.925	1.417	.024	.024	6	58,448	.51
GEZ022ES	GEZ022ES-2RS	1.3750	1.3745	2.1875	2.1870	1.187	1.182	1.031	1.019	1.515	.024	.039	6	69,688	.77
GEZ024ES	GEZ024ES-2RS	1.5000	1.4995	2.4375	2.4370	1.312	1.307	1.125	1.113	1.622	.024	.039	6	84,300	.93
GEZ028ES	GEZ028ES-2RS	1.7500	1.7495	2.8125	2.8120	1.531	1.526	1.312	1.300	1.996	.024	.039	6	114,648	1.41
GEZ032ES	GEZ032ES-2RS	2.0000	1.9995	3.1875	3.1869	1.750	1.745	1.500	1.484	2.280	.024	.039	6	150,616	2.06
GEZ036ES	GEZ036ES-2RS	2.2500	2.2494	3.5625	3.5619	1.969	1.963	1.687	1.671	2.555	.024	.039	6	191,080	2.93
GEZ040ES	GEZ040ES-2RS	2.5000	2.4994	3.9375	3.9369	2.187	2.181	1.875	1.859	2.886	.039	.039	6	238,288	4.08
GEZ044ES	GEZ044ES-2RS	2.7500	2.7494	4.3750	4.3744	2.406	2.400	2.062	2.046	3.114	.039	.039	6	281,000	5.34
GEZ048ES	GEZ048ES-2RS	3.0000	2.9994	4.7500	4.7493	2.625	2.619	2.250	2.230	3.417	.039	.039	6	337,200	6.83
GEZ052ES	GEZ052ES-2RS	3.2500	3.2492	5.1250	5.1243	2.844	2.836	2.437	2.417	3.720	.039	.039	6	395,648	8.42
GEZ056ES	GEZ056ES-2RS	3.5000	3.4992	5.5000	5.4993	3.062	3.054	2.625	2.605	4.000	.039	.039	6	458,592	10.56
GEZ060ES	GEZ060ES-2RS	3.7500	3.7492	5.8750	5.8743	3.281	3.273	2.812	2.792	4.280	.039	.039	6	530,528	12.74
GEZ064ES	GEZ064ES-2RS	4.0000	3.9992	6.2500	6.2490	3.500	3.492	3.000	2.980	4.559	.039	.039	6	595,720	15.41
GEZ068ES	GEZ068ES-2RS	4.2500	4.2492	6.6250	6.6240	3.719	3.711	3.187	3.167	4.835	.039	.039	6	674,400	18.54
GEZ072ES	GEZ072ES-2RS	4.5000	4.4992	7.0000	6.9990	3.937	3.929	3.375	3.355	5.142	.039	.039	6	764,320	21.58
GEZ076ES	GEZ076ES-2RS	4.7500	4.7490	7.3750	7.3738	4.156	4.148	3.562	3.542	5.417	.039	.039	6	843,000	25.35
GEZ080ES	GEZ080ES-2RS	5.0000	4.9990	7.7500	7.7488	4.375	4.365	3.750	3.730	5.720	.039	.039	6	932,920	29.76
GEZ096ES	GEZ096ES-2RS	6.0000	5.9990	8.7500	8.7488	4.750	4.740	4.125	4.105	6.622	.039	.039	5	1,168,960	38.58

For suggested housing bores, see page 111

# SPHERICAL PLAIN BEARINGS

Inch – Sealed – PTFE Lined



## GEZ..ET-2RS SEALED

**Race** - 52100 steel, heat treated, single fracture, PTFE lined.

**Ball** - 52100 steel, heat treated, hard chrome plated.

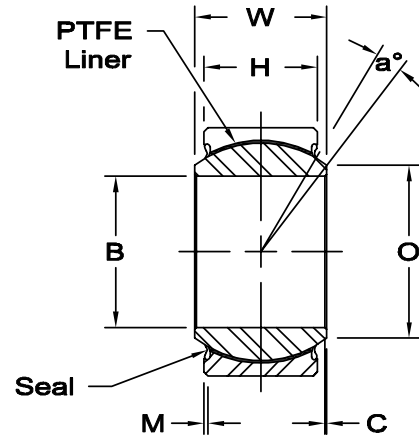
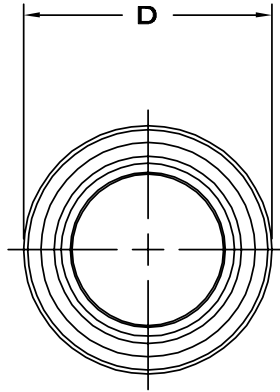

### RADIAL STATIC LOAD CAPACITY

These loads are the maximum safe operating loads for stationary applications, and assumes a sufficiently rigid housing and shaft. The radial static load capacity provides a 1.5 factor of safety against static fracture.

### LUBRICATION

Self lubricating PTFE liner.

The dimensions and tolerances apply before surface treatment and splitting of the outer race. The outer race can become slightly out of round due to splitting, but when the bearing is mounted into the bearing housing, the roundness of the outer race will be restored. The measured value of the bearing outside diameter without mounting is not to be used as the original actual value of the outside diameter.

BEARING NO.	DIMENSIONS IN INCHES											a° Misalign. Angle	Radial Static Limit Load Capacity Lbs.	Approx. Brg. Wt. Lbs.
	B Bore Dia.		D Race Dia.		W Ball Width		H Race Width		O Flat Dia.	C Ball Cmfr.	M Race Cmfr.			
	Max.	Min.	Max.	Min.	Max.	Min.	Max.	Min.	Min.	Min.	Min.			
GEZ012ET-2RS	.7500	.7495	1.2500	1.2495	.656	.651	.562	.552	.858	.012	.024	6	26,302	.12
GEZ014ET-2RS	.8750	.8745	1.4375	1.4370	.765	.760	.656	.646	1.000	.012	.024	6	35,968	.19
GEZ016ET-2RS	1.0000	.9995	1.6250	1.6245	.875	.870	.750	.740	1.087	.012	.024	6	56,200	.27
GEZ020ET-2RS	1.2500	1.2495	2.0000	1.9995	1.093	1.088	.937	.925	1.417	.024	.024	6	87,672	.51
GEZ022ET-2RS	1.3750	1.3745	2.1875	2.1870	1.187	1.182	1.031	1.019	1.515	.024	.039	6	103,408	.77
GEZ024ET-2RS	1.5000	1.4995	2.4375	2.4370	1.312	1.307	1.125	1.113	1.622	.024	.039	6	125,888	.93
GEZ028ET-2RS	1.7500	1.7495	2.8125	2.8120	1.531	1.526	1.312	1.300	1.996	.024	.039	6	171,972	1.41
GEZ032ET-2RS	2.0000	1.9995	3.1875	3.1869	1.750	1.745	1.500	1.484	2.280	.024	.039	6	224,800	2.06
GEZ036ET-2RS	2.2500	2.2494	3.5625	3.5619	1.969	1.963	1.687	1.671	2.555	.024	.039	6	283,248	2.93
GEZ040ET-2RS	2.5000	2.4994	3.9375	3.9369	2.187	2.181	1.875	1.859	2.886	.039	.039	6	352,936	4.08
GEZ044ET-2RS	2.7500	2.7494	4.3750	4.3744	2.406	2.400	2.062	2.046	3.114	.039	.039	6	422,624	5.34
GEZ048ET-2RS	3.0000	2.9994	4.7500	4.7493	2.625	2.619	2.250	2.230	3.417	.039	.039	6	505,800	6.83
GEZ052ET-2RS	3.2500	3.2492	5.1250	5.1243	2.844	2.836	2.437	2.417	3.720	.039	.039	6	595,720	8.42
GEZ056ET-2RS	3.5000	3.4992	5.5000	5.4993	3.062	3.054	2.625	2.605	4.000	.039	.039	6	690,136	10.56
GEZ060ET-2RS	3.7500	3.7492	5.8750	5.8743	3.281	3.273	2.812	2.792	4.280	.039	.039	6	791,296	12.74
GEZ064ET-2RS	4.0000	3.9992	6.2500	6.2490	3.500	3.492	3.000	2.980	4.559	.039	.039	6	899,200	15.41
GEZ068ET-2RS	4.2500	4.2492	6.6250	6.6240	3.719	3.711	3.187	3.167	4.835	.039	.039	6	1,013,848	18.54
GEZ072ET-2RS	4.5000	4.4992	7.0000	6.9990	3.937	3.929	3.375	3.355	5.142	.039	.039	6	1,139,736	21.58
GEZ076ET-2RS	4.7500	4.7490	7.3750	7.3738	4.156	4.148	3.562	3.542	5.417	.039	.039	6	1,270,120	25.35
GEZ080ET-2RS	5.0000	4.9990	7.7500	7.7488	4.375	4.365	3.750	3.730	5.720	.039	.039	6	1,409,496	29.76
GEZ096ET-2RS	6.0000	5.9990	8.7500	8.7488	4.750	4.740	4.125	4.105	6.622	.039	.039	5	1,753,440	38.58



# SPHERICAL PLAIN BEARINGS

Heavy Duty Inch – Open & Sealed



**GEGZ..ES**  
OPEN

**GEGZ..ES-2RS**  
SEALED

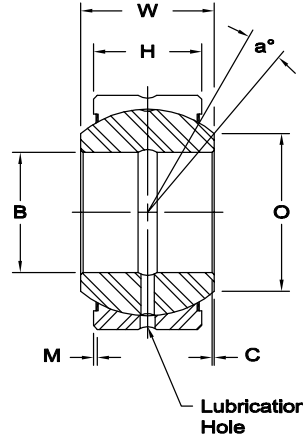
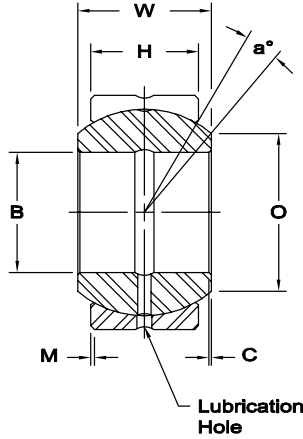
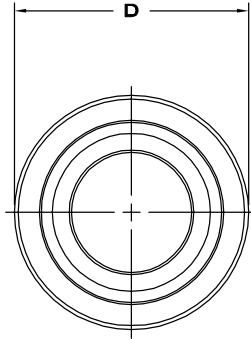

**GEGZ..ES**  
OPEN

**GEGZ..ES-2RS**  
SEALED

**Race** - 52100 steel, heat treated, protective coated for corrosion resistance.

**Ball** - 52100 steel, heat treated, protective coated for corrosion resistance.

### RADIAL STATIC LOAD CAPACITY

These loads are the maximum safe operating loads for stationary applications, and assumes a sufficiently rigid housing and shaft. The radial static load capacity provides a 1.5 factor of safety against static fracture.

### LUBRICATION

Bearings should only be used as delivered for static applications. For dynamic applications, a lithium-based grease with EP and  $MOS_2$  additives is especially suitable. Lubricants of this type are recommended for operating temperatures between  $-40^\circ F$  and  $+250^\circ F$  ( $-40^\circ C$  and  $+121^\circ C$ ). For operating temperatures outside of this range, consult lubricant manufacturer.

Bearings should be adequately lubricated before installation, and relubricated at suitable intervals based on application demands. Demand factors include load and load direction, misalignment angle and frequency, ambient temperature and contamination level.

The dimensions and tolerances apply before surface treatment and splitting of the outer race. The outer race can become slightly out of round due to splitting, but when the bearing is mounted into the bearing housing, the roundness of the outer race will be restored. The measured value of the bearing outside diameter without mounting is not to be used as the original actual value of the outside diameter.

BEARING NO.		DIMENSIONS IN INCHES											a° Misalign. Angle	Radial Static Limit Load Capacity Lbs.	Approx. Brg. Wt. Lbs.
OPEN	SEALED	B Bore Dia.		D Race Dia.		W Ball Width		H Race Width		O Flat Dia.	C Ball Cmfr.	M Race Cmfr.			
		Max.	Min.	Max.	Min.	Max.	Min.	Max.	Min.	Min.	Min.	Min.			
GEGZ020ES	GEGZ020ES-2RS	1.2500	1.2495	2.4375	2.4370	1.390	1.385	1.125	1.113	1.645	.024	.040	8	84,300	1.00
GEGZ024ES	GEGZ024ES-2RS	1.5000	1.4995	2.8125	2.8120	1.580	1.575	1.312	1.300	1.958	.024	.040	7	114,648	1.60
GEGZ028ES	GEGZ028ES-2RS	1.7500	1.7495	3.1875	3.1869	1.820	1.815	1.500	1.484	2.224	.024	.040	7	150,616	2.51
GEGZ032ES	GEGZ032ES-2RS	2.0000	1.9994	3.5625	3.5619	2.070	2.064	1.687	1.671	2.477	.024	.040	8	191,080	3.70
GEGZ036ES	GEGZ036ES-2RS	2.2500	2.2494	3.9375	3.9369	2.318	2.312	1.875	1.859	2.783	.024	.040	8	238,288	4.43
GEGZ040ES	GEGZ040ES-2RS	2.5000	2.4994	4.3750	4.3744	2.545	2.539	2.062	2.046	3.004	.040	.040	8	281,000	6.50
GEGZ044ES	GEGZ044ES-2RS	2.7500	2.7494	4.7500	4.7493	2.790	2.784	2.250	2.230	3.286	.040	.040	8	337,200	8.00
GEGZ048ES	GEGZ048ES-2RS	3.0000	2.9994	5.1250	5.1243	3.022	3.016	2.437	2.417	3.580	.040	.040	8	395,648	9.61
GEGZ052ES	GEGZ052ES-2RS	3.2500	3.2492	5.5000	5.4993	3.265	3.257	2.625	2.605	3.838	.040	.040	8	458,592	11.71
GEGZ056ES	GEGZ056ES-2RS	3.5000	3.4992	5.8750	5.8743	3.560	3.552	2.812	2.792	4.052	.040	.040	9	530,528	15.01
GEGZ060ES	GEGZ060ES-2RS	3.7500	3.7492	6.2500	6.2490	3.738	3.730	3.000	2.980	4.367	.040	.040	9	595,720	19.51
GEGZ064ES	GEGZ064ES-2RS	4.0000	3.9992	7.0000	6.9990	4.225	4.217	3.375	3.355	4.908	.040	.040	9	764,320	22.49
GEGZ072ES	GEGZ072ES-2RS	4.5000	4.4992	7.7500	7.7488	4.690	4.682	3.750	3.726	5.470	.040	.040	9	932,920	29.98
GEGZ088ES	GEGZ088ES-2RS	5.5000	5.4990	8.7500	8.7488	4.950	4.940	4.125	4.101	6.475	.040	.040	6	1,168,960	44.97



# SPHERICAL PLAIN BEARINGS

Extended Width Ball Inch – Open & Sealed



**GEWZ..ES**  
OPEN

**GEWZ..ES-2RS**  
SEALED



**Race** - 52100 steel, heat treated, protective coated for corrosion resistance.

**Ball** - 52100 steel, heat treated, protective coated for corrosion resistance.

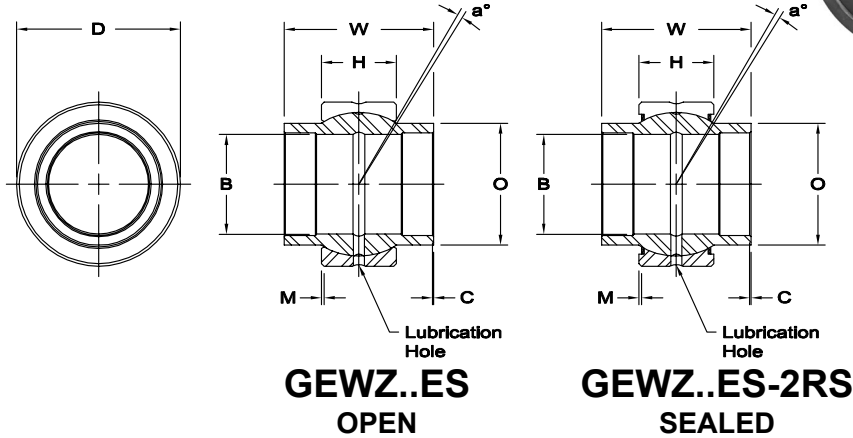

## RADIAL STATIC LOAD CAPACITY

These loads are the maximum safe operating loads for stationary applications, and assumes a sufficiently rigid housing and shaft. The radial static load capacity provides a 1.5 factor of safety against static fracture.

## LUBRICATION

Bearings should only be used as delivered for static applications. For dynamic applications, a lithium-based grease with EP and MOS<sub>2</sub> additives is especially suitable. Lubricants of this type are recommended for operating temperatures between -40° F and +250° F (-40° C and +121° C). For operating temperatures outside of this range, consult lubricant manufacturer.

Bearings should be adequately lubricated before installation, and relubricated at suitable intervals based on application demands. Demand factors include load and load direction, misalignment angle and frequency, ambient temperature and contamination level.

The dimensions and tolerances apply before surface treatment and splitting of the outer race. The outer race can become slightly out of round due to splitting, but when the bearing is mounted into the bearing housing, the roundness of the outer race will be restored. The measured value of the bearing outside diameter without mounting is not to be used as the original actual value of the outside diameter.

BEARING NO.		DIMENSIONS IN INCHES										a° Misalign. Angle	Radial Static Limit Load Capacity Lbs.	Approx. Brg. Wt. Lbs.	
OPEN	SEALED	B Bore Dia.		D Race Dia.		W Ball Width		H Race Width		O Flat Dia.	C Ball Cmfr.				M Race Cmfr.
		Max.	Min.	Max.	Min.	Max.	Min.	Max.	Min.	Min.	Min.				Min.
GEWZ008ES	GEWZ008ES-2RS	.5000	.4995	.8750	.8745	.750	.745	.375	.366	.625	.006	.024	5	9,217	.05
GEWZ010ES	GEWZ010ES-2RS	.6250	.6245	1.0625	1.0620	.937	.932	.469	.460	.780	.006	.024	5	14,612	.08
GEWZ012ES	GEWZ012ES-2RS	.7500	.7495	1.2500	1.2495	1.125	1.120	.562	.553	.920	.012	.024	5	21,356	.14
GEWZ014ES	GEWZ014ES-2RS	.8750	.8745	1.4375	1.4370	1.312	1.307	.656	.647	1.070	.012	.024	5	28,550	.22
GEWZ016ES	GEWZ016ES-2RS	1.0000	.9995	1.6250	1.6245	1.500	1.495	.750	.741	1.220	.012	.024	5	37,317	.31
GEWZ020ES	GEWZ020ES-2RS	1.2500	1.2495	2.0000	1.9995	1.875	1.870	.937	.925	1.525	.024	.024	5	58,448	.60
GEWZ022ES	GEWZ022ES-2RS	1.3750	1.3745	2.1875	2.1870	2.062	2.057	1.031	1.019	1.670	.024	.040	5	69,688	.82
GEWZ024ES	GEWZ024ES-2RS	1.5000	1.4995	2.4375	2.4370	2.250	2.245	1.125	1.113	1.850	.024	.040	5	84,300	1.09
GEWZ028ES	GEWZ028ES-2RS	1.7500	1.7495	2.8125	2.8120	2.625	2.620	1.312	1.300	2.165	.024	.040	5	114,648	1.68
GEWZ032ES	GEWZ032ES-2RS	2.0000	1.9994	3.1875	3.1869	3.000	2.994	1.500	1.484	2.460	.024	.040	5	150,616	2.45
GEWZ036ES	GEWZ036ES-2RS	2.2500	2.2494	3.5625	3.5619	3.375	3.369	1.687	1.671	2.760	.024	.040	5	191,080	3.46
GEWZ040ES	GEWZ040ES-2RS	2.5000	2.4994	3.9375	3.9369	3.750	3.744	1.875	1.859	3.060	.040	.040	5	238,288	4.74
GEWZ044ES	GEWZ044ES-2RS	2.7500	2.7494	4.3750	4.3744	4.125	4.119	2.062	2.046	3.380	.040	.040	5	281,000	6.39
GEWZ048ES	GEWZ048ES-2RS	3.0000	2.9994	4.7500	4.7493	4.500	4.494	2.250	2.230	3.675	.040	.040	5	337,200	7.91
GEWZ052ES	GEWZ052ES-2RS	3.2500	3.2492	5.1250	5.1243	4.875	4.867	2.437	2.417	3.985	.040	.040	5	395,648	10.34
GEWZ056ES	GEWZ056ES-2RS	3.5000	3.4992	5.5000	5.4993	5.250	5.242	2.625	2.605	4.300	.040	.040	5	458,592	12.92
GEWZ060ES	GEWZ060ES-2RS	3.7500	3.7492	5.8750	5.8743	5.625	5.617	2.812	2.792	4.590	.040	.040	5	530,528	15.67
GEWZ064ES	GEWZ064ES-2RS	4.0000	3.9992	6.2500	6.2490	6.000	5.992	3.000	2.980	4.905	.040	.040	5	595,720	18.87
GEWZ072ES	GEWZ072ES-2RS	4.5000	4.4992	7.0000	6.9990	6.750	6.742	3.375	3.355	5.525	.040	.040	5	764,320	26.98
GEWZ080ES	GEWZ080ES-2RS	5.0000	4.9990	7.7500	7.7488	7.500	7.490	3.750	3.726	6.130	.040	.040	5	932,920	36.66
GEWZ096ES	GEWZ096ES-2RS	6.0000	5.9990	8.7500	8.7488	8.250	8.240	4.125	4.101	7.020	.040	.040	5	1,168,960	45.64



# ANGULAR CONTACT SPHERICAL PLAIN BEARINGS

Inch



## GACZ..S OPEN

**Race** - 52100 steel, heat treated, protective coated for corrosion resistance

**Ball** - 52100 steel, heat treated, protective coated for corrosion resistance.

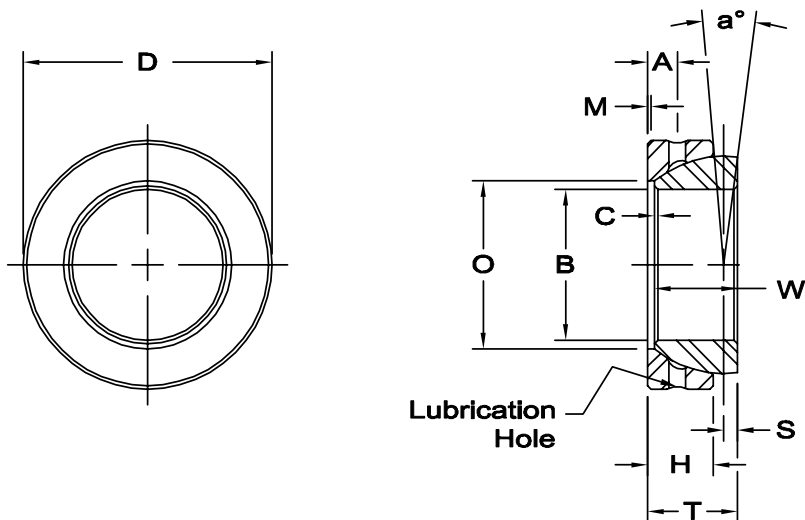

### LUBRICATION

Bearings should only be used as delivered for static applications. For dynamic applications, a lithium-based grease with EP and  $MOS_2$  additives is especially suitable. Lubricants of this type are recommended for operating temperatures between  $-40^\circ F$  and  $+250^\circ F$  ( $-40^\circ C$  and  $+121^\circ C$ ). For operating temperatures outside of this range, consult lubricant manufacturer.

Bearings should be adequately lubricated before installation, and relubricated at suitable intervals based on application demands. Demand factors include load and load direction, misalignment angle and frequency, ambient temperature and contamination level.

BEARING NO.	DIMENSIONS IN INCHES													a° Misalign. Angle	Static Thrust Load Capacity Lbs.	Approx. Brg. Wt. Lbs.
	B Bore Dia.		D Race Dia.		W Ball Width		H Race Width		T Ref.	Spherical Dia.	S Loc. Sphere Dia.	A End to Hole Ref.	C,M Ball, Race Cmfr. Min.			
	Max.	Min.	Max.	Min.	Max.	Min.	Max.	Min.		Ref.						
GACZ008S	.5000	.4995	.8750	.8745	.270	.261	.190	.181	.300	.719	.051	.094	.020	7	4,046	.03
GACZ010S	.6250	.6245	1.0625	1.0619	.340	.331	.250	.241	.370	.899	.058	.109	.030	6	6,969	.06
GACZ012S	.7500	.7495	1.2500	1.2494	.410	.401	.310	.301	.440	1.080	.070	.125	.040	6	10,566	.08
GACZ014S	.8750	.8745	1.4375	1.4369	.480	.471	.380	.371	.520	1.258	.080	.172	.080	5.5	14,837	.11
GACZ016S	1.0000	.9995	1.6250	1.6244	.550	.541	.440	.431	.600	1.437	.100	.203	.080	6	19,558	.19
GACZ020S	1.2500	1.2495	2.0000	1.9994	.700	.691	.550	.538	.740	1.795	.132	.234	.080	6	31,922	.35
GACZ022S	1.3750	1.3745	2.1875	2.1869	.770	.761	.600	.588	.840	1.937	.145	.281	.100	4	35,743	.47
GACZ024S	1.5000	1.4995	2.4375	2.4369	.840	.831	.660	.648	.910	2.155	.155	.312	.100	5.5	44,286	.66
GACZ028S	1.7500	1.7495	2.8125	2.8119	.980	.971	.790	.778	1.070	2.515	.186	.328	.100	6	61,370	1.01
GACZ032S	2.0000	1.9994	3.1875	3.1868	1.130	1.118	.920	.908	1.230	2.875	.217	.375	.140	5.5	82,052	1.48
GACZ036S	2.2500	2.2494	3.5625	3.5618	1.270	1.258	1.050	1.034	1.390	3.235	.243	.453	.140	5.5	104,757	2.09
GACZ040S	2.5000	2.4994	3.9375	3.9368	1.420	1.408	1.180	1.164	1.540	3.590	.267	.500	.140	5	132,407	2.49
GACZ044S	2.7500	2.7494	4.3750	4.3773	1.560	1.548	1.275	1.259	1.700	3.950	.294	.515	.180	5	156,011	3.86
GACZ048S	3.0000	2.9994	4.7500	4.7492	1.710	1.698	1.405	1.389	1.860	4.312	.322	.578	.180	5	188,382	5.03
GACZ052S	3.2500	3.2492	5.1250	5.1242	1.860	1.844	1.545	1.529	2.030	4.675	.356	.656	.180	5	223,676	6.37
GACZ056S	3.5000	3.4992	5.5000	5.4992	2.000	1.984	1.675	1.659	2.180	5.040	.374	.703	.180	5	262,342	7.87
GACZ060S	3.7500	3.7492	5.8750	5.8742	2.150	2.134	1.805	1.789	2.340	5.390	.398	.765	.180	4.5	303,030	9.59
GACZ064S	4.0000	3.9992	6.2500	6.2490	2.300	2.284	1.935	1.919	2.500	5.750	.409	.781	.180	4.5	347,316	11.60
GACZ072S	4.5000	4.4992	7.0000	6.9990	2.590	2.574	2.195	2.179	2.800	6.475	.488	.875	.180	4.5	447,352	17.11
GACZ080S	5.0000	4.9990	7.7500	7.7488	2.880	2.860	2.455	2.435	3.130	7.190	.547	1.000	.180	4.5	551,884	24.41
GACZ096S	6.0000	5.9990	8.7500	8.7488	3.100	3.080	2.615	2.595	3.375	8.156	.634	1.370	.180	4.5	664,284	38.29

## ALTERNATIVES TO FRACTURED RACE BEARINGS

READER  
KNOWLEDGE  
REFERENCE  
**020**

Most spherical bearings used in motorsport applications incorporate single-piece race construction, with the raceway formed around the ball. Swaged bearings provide close tolerance fits, allowing precise motion control.

Dampers and strut mounts (camber plates) often incorporate fractured race bearings, which use raceways manufactured separately from the ball, fractured across the circumference, and spread open to be assembled around the ball. Because the components are finished separately, these bearings do not have the ball to race conformity or close tolerance fit of swaged bearings. Industrially, they are intended primarily for static situations or slow dynamic applications, with incidental misalignment.

They are generally the least expensive form of spherical bearing, and not dimensionally interchangeable with common swaged bearings.

Swaged bearings are designed to accommodate regular misalignment. **Materials** are chosen to provide dynamic load-bearing capacity, as well as durability. Used in dynamic motorsport applications, users often find fractured race bearings deliver less than the desired precision and durability.

Alternatives to the metal-on-metal fractured race bearing are available, but not readily known. As with swaged bearings, PTFE lined alternatives are available from many bearing manufacturers. Fractured race bearing part numbers generally carry a suffix 'ES'.

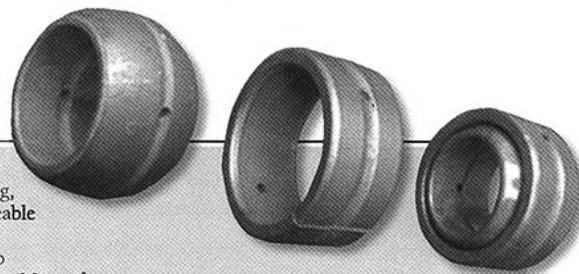

Replacing this with a 'C' or 'ET-2RS' will specify the dimensional equivalent with a self-lubricating, clearance diminishing or eliminating PTFE liner. Certain manufacturers also offer full swage equivalents. Ultimately, manufacturer consultation will prove useful in determining beneficial specification upgrades.

**Professional  
MotorSport**  
WORLD EXPO 2007  
6,7,8 NOVEMBER COLOGNE, GERMANY  
EXHIBITOR

→ Further information: John McCrory at Aurora Bearings. Email: [jmccrory@aurorabearing.com](mailto:jmccrory@aurorabearing.com)

### THE ABOVE ORIGINALLY APPEARED IN PROFESSIONAL MOTORSPORT WORLD

Professional Motorsport World is the international magazine designed specifically for people at the cutting edge of automotive development. Professional Motorsport World comprises news, interviews and articles covering the full spectrum of motorsport technology, issues, and strategies, as well as the general business of operating within motorsport. Professional Motorsport World is published by the team behind Automotive Testing Technology International, Vehicle Dynamics International, and Engine Technology International.

[www.ukipme.com/mag\\_motorsport.htm](http://www.ukipme.com/mag_motorsport.htm)





**GE..ES**  
**OPEN**

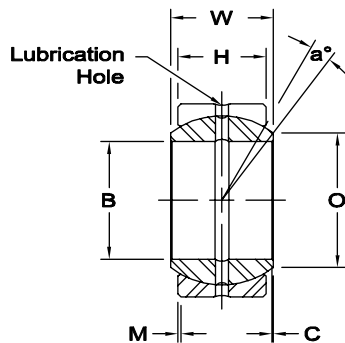

**GE..ES**  
**OPEN**

**GE..ES-2RS**  
**SEALED**

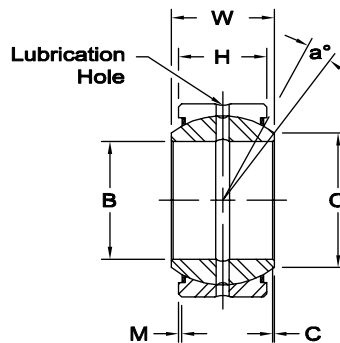

**GE..ES-2RS**  
**SEALED**

**Race** - 52100 steel, heat treated, protective coated for corrosion resistance.

**Ball** - 52100 steel, heat treated, protective coated for corrosion resistance.

### RADIAL STATIC LOAD CAPACITY

These loads are the maximum safe operating loads for stationary applications, and assumes a sufficiently rigid housing and shaft. The radial static load capacity provides a 1.5 factor of safety against static fracture

### LUBRICATION

Bearings should only be used as delivered for static applications. For dynamic applications, a lithium-based grease with EP and MOS<sub>2</sub> additives is especially suitable. Lubricants of this type are recommended for operating temperatures between -40° F and + 250° F (-40° C and +121° C). For operating temperatures outside of this range, consult lubricant manufacturer.

Bearings should be adequately lubricated before installation, and relubricated at suitable intervals based on application demands. Demand factors include load and load direction, misalignment angle and frequency, ambient temperature and contamination level

The dimensions and tolerances apply before surface treatment and splitting of the outer race. The outer race can become slightly out of round due to splitting, but when the bearing is mounted into the bearing housing, the roundness of the outer race will be restored. The measured value of the bearing outside diameter without mounting is not to be used as the original actual value of the outside diameter..

\* GE-12E only available without lube grooves and holes.

BEARING NO.		DIMENSIONS IN MILLIMETERS											a° Misalign. Angle	Radial Static Limit Load Capacity kN	Approx. Brg. Wt. Grams	
OPEN	SEALED	B Bore Dia.		D Race Dia.		W Ball Width		H Race Width		O Flat Dia.	C Ball Cmfr.	M Race Cmfr.				
		Max.	Min.	Max.	Min.	Max.	Min.	Max.	Min.	Min.	Min.					
*	GE12E		12.000	11.992	22.000	21.991	10.00	9.88	7.00	6.76	15	0.3	0.3	10	53	15
	GE15ES	GE15ES-2RS	15.000	14.992	26.000	25.991	12.00	11.88	9.00	8.76	18	0.3	0.3	8	84	27
	GE17ES	GE17ES-2RS	17.000	16.992	30.000	29.991	14.00	13.88	10.00	9.76	20	0.3	0.3	10	106	41
	GE20ES	GE20ES-2RS	20.000	19.990	35.000	34.989	16.00	15.88	12.00	11.76	24	0.3	0.3	9	146	66
	GE25ES	GE25ES-2RS	25.000	24.990	42.000	41.989	20.00	19.88	16.00	15.76	29	0.6	0.6	7	240	119
	GE30ES	GE30ES-2RS	30.000	29.990	47.000	46.989	22.00	21.88	18.00	17.76	34	0.6	0.6	6	310	153
	GE35ES	GE35ES-2RS	35.000	34.988	55.000	54.987	25.00	24.88	20.00	19.70	39	0.6	1.0	6	399	233
	GE40ES	GE40ES-2RS	40.000	39.988	62.000	61.987	28.00	27.88	22.00	21.70	45	0.6	1.0	7	495	306
	GE45ES	GE45ES-2RS	45.000	44.988	68.000	67.987	32.00	31.88	25.00	24.70	50	0.6	1.0	7	637	427
	GE50ES	GE50ES-2RS	50.000	49.988	75.000	74.987	35.00	34.88	28.00	27.70	55	0.6	1.0	6	780	546
	GE60ES	GE60ES-2RS	60.000	59.985	90.000	89.985	44.00	43.85	36.00	35.60	66	1.0	1.0	6	1,220	1,040
	GE70ES	GE70ES-2RS	70.000	69.985	105.000	104.985	49.00	48.85	40.00	39.60	77	1.0	1.0	6	1,560	1,550
	GE80ES	GE80ES-2RS	80.000	79.985	120.000	119.985	55.00	54.85	45.00	44.60	88	1.0	1.0	6	2,000	2,310
	GE90ES	GE90ES-2RS	90.000	89.980	130.000	129.982	60.00	59.80	50.00	49.50	98	1.0	1.0	5	2,440	2,750
	GE100ES	GE100ES-2RS	100.000	99.980	150.000	149.982	70.00	69.80	55.00	54.50	109	1.0	1.0	7	3,030	4,450
	GE110ES	GE110ES-2RS	110.000	109.980	160.000	159.975	70.00	69.80	55.00	54.50	120	1.0	1.0	6	3,270	4,820
	GE120ES	GE120ES-2RS	120.000	119.980	180.000	179.975	85.00	84.80	70.00	69.50	135	1.0	1.0	6	4,750	8,050
	GE140ES	GE140ES-2RS	140.000	139.975	210.000	209.970	90.00	89.75	70.00	69.40	155	1.0	1.0	7	5,355	11,020
	GE160ES	GE160ES-2RS	160.000	159.975	230.000	229.970	105.00	104.75	80.00	79.40	170	1.0	1.0	8	6,800	14,010

For suggested housing bores, see page 111

# SPHERICAL PLAIN BEARINGS

Metric – Sealed – PTFE Lined



## GE..ET-2RS SEALED

**Race** - 52100 steel, heat treated, single fracture, PTFE lined.

**Ball** - 52100 steel, heat treated, hard chrome plated.

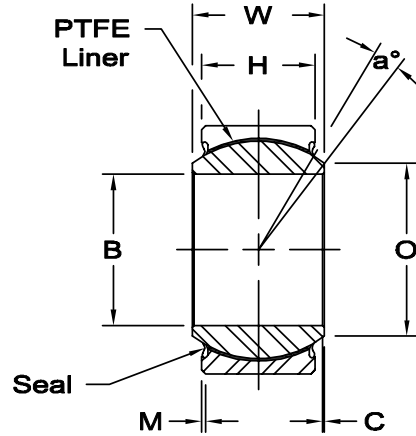
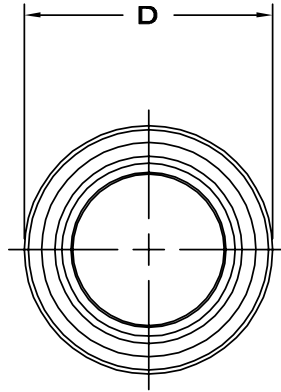

### RADIAL STATIC LOAD CAPACITY

These loads are the maximum safe operating loads for stationary applications, and assumes a sufficiently rigid housing and shaft. The radial static load capacity provides a 1.5 factor of safety against static fracture.

### LUBRICATION

Self lubricating PTFE liner.

The dimensions and tolerances apply before surface treatment and splitting of the outer race. The outer race can become slightly out of round due to splitting, but when the bearing is mounted into the bearing housing, the roundness of the outer race will be restored. The measured value of the bearing outside diameter without mounting is not to be used as the original actual value of the outside diameter.

\* Parts 140mm and above have a double fracture race.

BEARING NO.	DIMENSIONS IN MILLIMETERS											a° Misalign. Angle	Radial Static Limit Load Capacity kN	Approx. Brg. Wt. Grams
	B Bore Dia.		D Race Dia.		W Ball Width		H Race Width		O Flat Dia.	C Ball Cmfr.	M Race Cmfr.			
	Max.	Min.	Max.	Min.	Max.	Min.	Max.	Min.	Min.	Min.	Min.			
GE15ET-2RS	15.000	14.992	26.000	25.991	12.00	11.88	9.00	8.76	18	0.3	0.3	8	79	27
GE17ET-2RS	17.000	16.992	30.000	29.991	14.00	13.88	10.00	9.76	20	0.3	0.3	10	100	41
GE20ET-2RS	20.000	19.990	35.000	34.989	16.00	15.88	12.00	11.76	24	0.3	0.3	9	139	66
GE25ET-2RS	25.000	24.990	42.000	41.989	20.00	19.88	16.00	15.76	29	0.6	0.6	7	225	119
GE30ET-2RS	30.000	29.990	47.000	46.989	22.00	21.88	18.00	17.76	34	0.6	0.6	6	290	153
GE35ET-2RS	35.000	34.988	55.000	54.987	25.00	24.88	20.00	19.70	39	0.6	1.0	6	375	233
GE40ET-2RS	40.000	39.988	62.000	61.987	28.00	27.88	22.00	21.70	45	0.6	1.0	7	465	306
GE45ET-2RS	45.000	44.988	68.000	67.987	32.00	31.88	25.00	24.70	50	0.6	1.0	7	600	427
GE50ET-2RS	50.000	49.988	75.000	74.987	35.00	34.88	28.00	27.70	55	0.6	1.0	6	735	546
GE60ET-2RS	60.000	59.985	90.000	89.985	44.00	43.85	36.00	35.60	66	1.0	1.0	6	1,150	1,040
GE70ET-2RS	70.000	69.985	105.000	104.985	49.00	48.85	40.00	39.60	77	1.0	1.0	6	1,470	1,550
GE80ET-2RS	80.000	79.985	120.000	119.985	55.00	54.85	45.00	44.60	88	1.0	1.0	6	1,890	2,310
GE90ET-2RS	90.000	89.980	130.000	129.982	60.00	59.80	50.00	49.50	98	1.0	1.0	5	2,300	2,750
GE100ET-2RS	100.000	99.980	150.000	149.982	70.00	69.80	55.00	54.50	109	1.0	1.0	7	2,860	4,450
GE110ET-2RS	110.000	109.980	160.000	159.975	70.00	69.80	55.00	54.50	120	1.0	1.0	6	3,080	4,820
GE120ET-2RS	120.000	119.980	180.000	179.975	85.00	84.80	70.00	69.50	135	1.0	1.0	6	4,480	8,050
* GE140XT-2RS	140.000	139.975	210.000	209.970	90.00	89.75	70.00	69.40	155	1.0	1.0	7	5,040	11,020
* GE160XT-2RS	160.000	159.975	230.000	229.970	105.00	104.75	80.00	79.40	170	1.0	1.0	8	6,400	14,010



# SPHERICAL PLAIN BEARINGS

Heavy Duty Metric – Open & Sealed

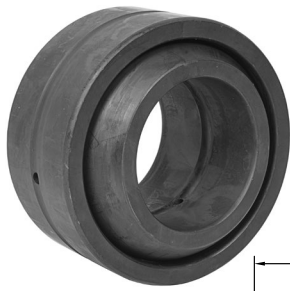

**GEG..ES  
OPEN**

**GEG..ES-2RS  
SEALED**

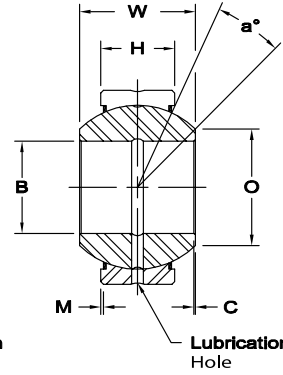
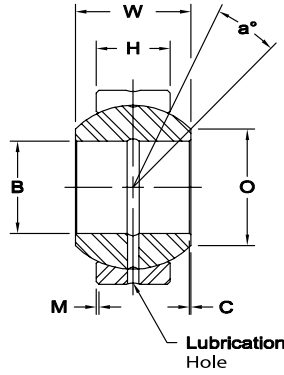
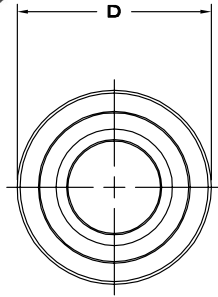

**GEG..ES  
OPEN**

**GEG..ES-2RS  
SEALED**

**Race** - 52100 steel, heat treated, protective coated for corrosion resistance.

**Ball** - 52100 steel, heat treated, protective coated for corrosion resistance.

### RADIAL STATIC LOAD CAPACITY

These loads are the maximum safe operating loads for stationary applications, and assumes a sufficiently rigid housing and shaft. The radial static load capacity provides a 1.5 factor of safety against static fracture

### LUBRICATION

Bearings should only be used as delivered for static applications. For dynamic applications, a lithium-based grease with EP and  $MOS_2$  additives is especially suitable. Lubricants of this type are recommended for operating temperatures between  $-40^\circ F$  and  $+250^\circ F$  ( $-40^\circ C$  and  $+121^\circ C$ ). For operating temperatures outside of this range, consult lubricant manufacturer.

Bearings should be adequately lubricated before installation, and relubricated at suitable intervals based on application demands. Demand factors include load and load direction, misalignment angle and frequency, ambient temperature and contamination level.

The dimensions and tolerances apply before surface treatment and splitting of the outer race. The outer race can become slightly out of round due to splitting, but when the bearing is mounted into the bearing housing, the roundness of the outer race will be restored. The measured value of the bearing outside diameter without mounting is not to be used as the original actual value of the outside diameter.

BEARING NO.		DIMENSIONS IN MILLIMETERS											a° Misalign. Angle	Radial Static Limit Load Capacity kN	Approx. Brg. Wt. Grams
OPEN	SEALED	B Bore Dia.		D Race Dia.		W Ball Width		H Race Width		O Flat Dia.	C Ball Cmfr.	M Race Cmfr.			
		Max.	Min.	Max.	Min.	Max.	Min.	Max.	Min.	Min.	Min.	Min.			
GEG12E		12.000	11.992	26.000	25.991	15.00	14.88	9.00	8.76	16.09	.3	.3	18	84	36
GEG15ES	GEG15ES-2RS	15.000	14.992	30.000	29.991	16.00	15.88	10.00	9.76	19.21	.3	.3	16	106	48
GEG17ES	GEG17ES-2RS	17.000	16.992	35.000	34.989	20.00	19.88	12.00	11.76	21.00	.3	.3	19	146	80
GEG20ES	GEG20ES-2RS	20.000	19.990	42.000	41.989	25.00	24.88	16.00	15.76	25.20	.3	.6	17	240	152
GEG25ES	GEG25ES-2RS	25.000	24.990	47.000	46.989	28.00	27.88	18.00	17.76	29.54	.6	.6	17	310	199
GEG30ES	GEG30ES-2RS	30.000	29.990	55.000	54.987	32.00	31.88	20.00	19.70	34.42	.6	1.0	17	399	296
GEG35ES	GEG35ES-2RS	35.000	34.988	62.000	61.987	35.00	34.88	22.00	21.70	39.80	.6	1.0	16	495	402
GEG40ES	GEG40ES-2RS	40.000	39.988	68.000	67.987	40.00	39.88	25.00	24.70	44.72	.6	1.0	17	637	535
GEG45ES	GEG45ES-2RS	45.000	44.988	75.000	74.987	43.00	42.88	28.00	27.70	50.07	.6	1.0	15	780	698
GEG50ES	GEG50ES-2RS	50.000	49.988	90.000	89.985	56.00	55.88	36.00	35.60	57.13	.6	1.0	17	1,220	1,420
GEG60ES	GEG60ES-2RS	60.000	59.985	105.000	104.985	63.00	62.85	40.00	39.60	67.04	1.0	1.0	17	1,560	2,090
GEG70ES	GEG70ES-2RS	70.000	69.985	120.000	119.985	70.00	69.85	45.00	44.60	78.26	1.0	1.0	16	2,000	3,010
GEG80ES	GEG80ES-2RS	80.000	79.985	130.000	129.982	75.00	74.85	50.00	49.50	87.18	1.0	1.0	14	2,440	3,610
GEG90ES	GEG90ES-2RS	90.000	89.980	150.000	149.982	85.00	84.80	55.00	54.50	98.36	1.0	1.0	15	3,030	5,500
GEG100ES	GEG100ES-2RS	100.000	99.980	160.000	159.975	85.00	84.80	55.00	54.50	111.24	1.0	1.0	14	3,270	6,040
GEG110ES	GEG110ES-2RS	110.000	109.980	180.000	179.975	100.00	99.80	70.00	69.50	124.90	1.0	1.0	12	4,750	9,740
GEG120ES	GEG120ES-2RS	120.000	119.980	210.000	209.970	115.00	114.80	70.00	69.40	138.47	1.0	1.0	16	5,350	15,100
GEG140ES	GEG140ES-2RS	140.000	139.975	230.000	229.970	130.00	129.75	80.00	79.40	151.99	1.0	1.0	16	6,800	18,900
GEG160ES	GEG160ES-2RS	160.000	159.975	260.000	259.965	135.00	134.75	80.00	79.30	180.00	1.1	1.1	16	7,650	24,800

# SPHERICAL PLAIN BEARINGS

Extended Width Ball Metric – Open & Sealed



## GEEW..ES OPEN

**Race** - 52100 steel, heat treated, protective coated for corrosion resistance.

**Ball** - 52100 steel, heat treated, protective coated for corrosion resistance.

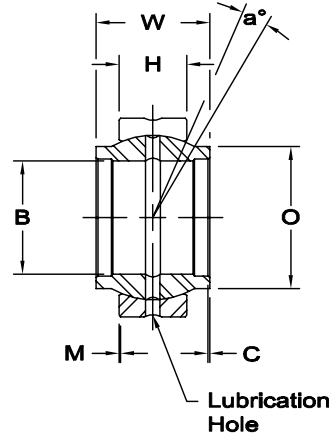
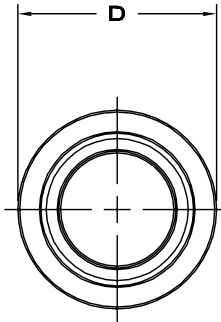

## GEEW..ES-2RS SEALED

### RADIAL STATIC LOAD CAPACITY

These loads are the maximum safe operating loads for stationary applications, and assumes a sufficiently rigid housing and shaft. The radial static load capacity provides a 1.5 factor of safety against static fracture

### LUBRICATION

Bearings should only be used as delivered for static applications. For dynamic applications, a lithium-based grease with EP and  $MOS_2$  additives is especially suitable. Lubricants of this type are recommended for operating temperatures between  $-40^\circ F$  and  $+250^\circ F$  ( $-40^\circ C$  and  $+121^\circ C$ ). For operating temperatures outside of this range, consult lubricant manufacturer.

Bearings should be adequately lubricated before installation, and relubricated at suitable intervals based on application demands. Demand factors include load and load direction, misalignment angle and frequency, ambient temperature and contamination level.

The dimensions and tolerances apply before surface treatment and splitting of the outer race. The outer race can become slightly out of round due to splitting, but when the bearing is mounted into the bearing housing, the roundness of the outer race will be restored. The measured value of the bearing outside diameter without mounting is not to be used as the original actual value of the outside diameter.

BEARING NO.		DIMENSIONS IN MILLIMETERS											a° Misalign. Angle	Radial Static Limit Load Capacity kN	Approx. Brg. Wt. Grams
OPEN	SEALED	B Bore Dia.		D Race Dia.		W Ball Width		H Race Width		O Flat Dia.	C Ball Cmfr.	M Race Cmfr.			
		Max.	Min.	Max.	Min.	Max.	Min.	Max.	Min.	Min.	Min.				
GEEW12ES		12.018	12.000	22.000	21.991	12.00	11.82	7.00	6.76	15.50	.30	.30	4	53	17
GEEW15ES	GEEW15ES-2RS	15.018	15.000	26.000	25.991	15.00	14.82	9.00	8.76	18.50	.30	.30	5	84	28
GEEW16ES	GEEW16ES-2RS	16.018	16.000	28.000	27.991	16.00	15.82	9.00	8.76	20.00	.30	.30	4	85	34
GEEW17ES	GEEW17ES-2RS	17.018	17.000	30.000	29.991	17.00	16.82	10.00	9.76	21.00	.30	.30	7	106	43
GEEW20ES	GEEW20ES-2RS	20.021	20.000	35.000	34.989	20.00	19.79	12.00	11.76	25.00	.30	.30	4	146	69
GEEW25ES	GEEW25ES-2RS	25.021	25.000	42.000	41.989	25.00	24.79	16.00	15.76	30.50	.60	.60	4	240	124
GEEW30ES	GEEW30ES-2RS	30.021	30.000	47.000	46.989	30.00	29.79	18.00	17.76	34.00	.60	.60	4	310	159
GEEW32ES	GEEW32ES-2RS	32.025	32.000	52.000	51.987	32.00	31.75	18.00	17.70	37.00	.60	1.00	4	328	207
GEEW35ES	GEEW35ES-2RS	35.025	35.000	55.000	54.987	35.00	34.75	20.00	19.70	40.00	.60	1.00	4	399	248
GEEW40ES	GEEW40ES-2RS	40.025	40.000	62.000	61.987	40.00	39.75	22.00	21.70	46.00	.60	1.00	4	495	349
GEEW45ES	GEEW45ES-2RS	45.025	45.000	68.000	67.987	45.00	44.75	25.00	24.70	52.00	.60	1.00	4	637	468
GEEW50ES	GEEW50ES-2RS	50.025	50.000	75.000	74.987	50.00	49.75	28.00	27.70	57.00	.60	1.00	4	780	620
GEEW60ES	GEEW60ES-2RS	60.030	60.000	90.000	89.985	60.00	59.70	36.00	35.60	68.00	1.00	1.00	4	1,220	1,110
GEEW63ES	GEEW63ES-2RS	63.030	63.000	95.000	94.985	63.00	62.70	36.00	35.60	71.50	1.00	1.00	4	1,260	1,270
GEEW70ES	GEEW70ES-2RS	70.030	70.000	105.000	104.985	70.00	69.70	40.00	39.60	78.00	1.00	1.00	4	1,560	1,690
GEEW80ES	GEEW80ES-2RS	80.030	80.000	120.000	119.985	80.00	79.70	45.00	44.60	91.00	1.00	1.00	4	2,000	2,550
GEEW90ES	GEEW90ES-2RS	90.035	90.000	130.000	129.982	90.00	89.65	50.00	49.50	99.00	1.00	1.00	4	2,440	3,040
GEEW100ES	GEEW100ES-2RS	100.035	100.000	150.000	149.982	100.00	99.65	55.00	54.50	113.00	1.00	1.00	4	3,030	4,870
GEEW110ES	GEEW110ES-2RS	110.035	110.000	160.000	159.975	110.00	109.65	55.00	54.50	124.00	1.00	1.00	4	3,270	5,530
GEEW125ES	GEEW125ES-2RS	125.040	125.000	180.000	179.975	125.00	124.60	70.00	69.50	138.00	1.00	1.00	4	4,750	8,190
GEEW160ES	GEEW160ES-2RS	160.040	160.000	230.000	229.970	160.00	159.60	80.00	79.40	177.00	1.00	1.00	4	6,800	15,800
GEEW200ES	GEEW200ES-2RS	200.046	200.000	290.000	289.965	200.00	199.54	100.00	99.30	221.00	1.10	1.10	4	10,600	31,700
GEEW250ES	GEEW250ES-2RS	250.046	250.000	400.000	399.960	250.00	249.54	120.00	119.20	317.00	1.10	1.10	4	17,800	101,000
GEEW320ES	GEEW320ES-2RS	320.057	320.000	520.000	519.950	320.00	319.43	160.00	159.00	405.00	1.10	1.10	4	30,500	225,000



# ANGULAR CONTACT SPHERICAL PLAIN BEARINGS

Metric

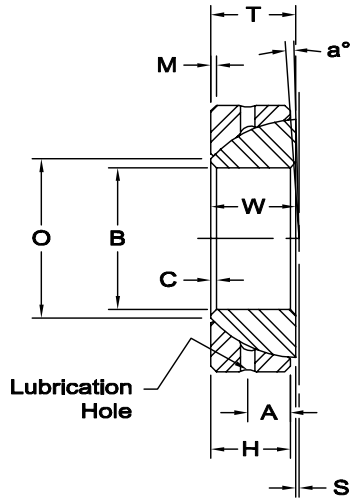
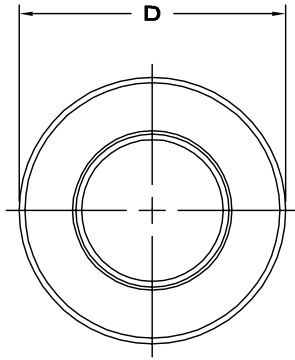

**GAC..S  
OPEN**

**Race** - 52100 steel, heat treated, protective coated for corrosion resistance.

**Ball** - 52100 steel, heat treated, protective coated for corrosion resistance.

### LUBRICATION

Bearings should only be used as delivered for static applications. For dynamic applications, a lithium-based grease with EP and  $\text{MOS}_2$  additives is especially suitable. Lubricants of this type are recommended for operating temperatures between  $-40^\circ\text{F}$  and  $+250^\circ\text{F}$  ( $-40^\circ\text{C}$  and  $+121^\circ\text{C}$ ). For operating temperatures outside of this range, consult lubricant manufacturer.

Bearings should be adequately lubricated before installation, and relubricated at suitable intervals based on application demands. Demand factors include load and load direction, misalignment angle and frequency, ambient temperature and contamination level.

BEARING NO.	DIMENSIONS IN MILLIMETERS													a° Misalign. Angle	Static Thrust Load Capacity kN	Approx. Brg. Wt. Grams
	B Bore Dia.		D Race Dia.		W Ball Width		H Race Width		T Ref.	Spherical Dia.	S Loc. Sphere Dia.	A End to Hole Ref.	C,M Ball, Race Cmfr. Min.			
	Max.	Min.	Max.	Min.	Max.	Min.	Max.	Min.		Ref.		Ref.	Min.			
GAC25S	25.000	24.988	47.000	46.986	15.00	14.76	14.00	13.76	15.00	42.00	.60	7.50	1.0	2.5	250	148
GAC28S	28.000	27.988	52.000	51.984	15.00	14.76	15.00	14.70	16.00	47.00	1.00	8.00	1.0	2.0	300	186
GAC30S	30.000	29.988	55.000	54.984	17.00	16.76	15.00	14.70	17.00	49.50	1.30	8.50	1.0	4.5	315	208
GAC32S	32.000	31.988	58.000	57.984	17.00	16.76	16.00	15.70	17.00	52.00	2.00	8.50	1.0	2.0	354	241
GAC35S	35.000	34.988	62.000	61.984	18.00	17.76	16.00	15.70	18.00	55.50	2.10	9.00	1.0	4.0	390	268
GAC40S	40.000	39.988	68.000	67.984	19.00	18.76	17.00	16.70	19.00	62.00	2.80	9.50	1.0	3.5	463	327
GAC45S	45.000	44.988	75.000	74.984	20.00	19.76	18.00	17.70	20.00	68.50	3.50	10.00	1.0	3.0	540	416
GAC50S	50.000	49.988	80.000	79.984	20.00	19.76	19.00	18.70	20.00	74.00	4.30	10.00	1.0	1.5	618	455
GAC55S	55.000	54.985	90.000	89.982	23.00	22.76	20.00	19.60	23.00	82.00	5.00	11.50	1.1	4.0	721	645
GAC60S	60.000	59.985	95.000	94.982	23.00	22.70	21.00	20.60	23.00	88.50	5.70	11.50	1.1	2.5	817	714
GAC65S	65.000	64.985	100.000	99.982	23.00	22.70	22.00	21.60	23.00	93.50	6.50	11.50	1.1	1.0	905	759
GAC70S	70.000	69.985	110.000	109.982	25.00	24.70	23.00	22.60	25.00	102.00	7.20	12.50	1.1	2.0	1,030	1,040
GAC75S	75.000	74.985	115.000	114.982	25.00	24.70	24.00	23.60	25.00	107.00	7.90	12.50	1.1	1.0	1,129	1,120
GAC80S	80.000	79.985	125.000	124.980	29.00	28.70	25.50	25.00	29.00	115.00	8.60	14.50	1.1	3.5	1,290	1,540
GAC85S	85.000	84.980	130.000	129.980	29.00	28.60	26.50	26.00	29.00	122.00	9.40	14.50	1.1	2.0	1,422	1,610
GAC90S	90.000	89.980	140.000	139.980	32.00	31.60	28.00	27.50	32.00	128.50	10.10	16.00	1.5	3.5	1,580	2,090
GAC95S	95.000	94.980	145.000	144.980	32.00	31.60	29.50	29.00	32.00	135.00	10.80	16.00	1.5	2.0	1,750	2,220
GAC100S	100.000	99.980	150.000	149.980	32.00	31.60	31.00	30.50	32.00	141.00	11.60	16.00	1.5	.5	1,923	2,340
GAC105S	105.000	104.980	160.000	159.975	35.00	34.60	32.50	32.00	35.00	148.00	12.30	17.50	2.0	2.0	2,116	2,930
GAC110S	110.000	109.980	170.000	169.975	38.00	37.60	34.00	33.50	38.00	155.00	13.00	19.00	2.0	3.0	2,318	3,680
GAC120S	120.000	119.980	180.000	179.975	38.00	37.60	37.00	36.50	38.00	168.00	14.50	19.00	2.0	.5	2,735	3,970
GAC130S	130.000	129.975	200.000	199.970	45.00	44.50	43.00	42.40	45.00	188.00	18.00	19.00	2.5	1.0	3,550	5,920
GAC140S	140.000	139.975	210.000	209.970	45.00	44.50	43.00	42.40	45.00	198.00	19.00	19.00	2.5	1.0	3,740	6,330
GAC150S	150.000	149.975	225.000	224.970	48.00	47.50	46.00	45.40	48.00	211.00	20.00	20.50	3.0	1.0	4,270	8,010
GAC160S	160.000	159.975	240.000	239.970	51.00	50.50	49.00	48.40	51.00	225.00	20.00	22.00	3.0	1.0	4,850	9,790
GAC170S	170.000	169.975	260.000	259.965	57.00	56.50	55.00	54.30	57.00	246.00	21.00	27.00	3.0	1.0	5,950	12,300
GAC180S	180.000	179.975	280.000	279.965	64.00	63.50	61.00	60.30	64.00	260.00	21.00	28.00	3.0	1.0	6,970	17,400
GAC190S	190.000	189.970	290.000	289.965	64.00	63.40	62.00	61.30	64.00	275.00	26.00	30.00	3.0	0.5	7,500	18,200
GAC200S	200.000	199.970	310.000	309.965	70.00	69.40	66.00	65.30	70.00	290.00	26.00	30.00	3.0	1.5	8,420	23,800



# ANGULAR CONTACT SPHERICAL PLAIN BEARINGS

Metric – PTFE Lined



**GAC..T**

**Race** - 52100 steel, heat treated, PTFE lined.

**Ball** - 52100 steel, heat treated, hard chrome plated.

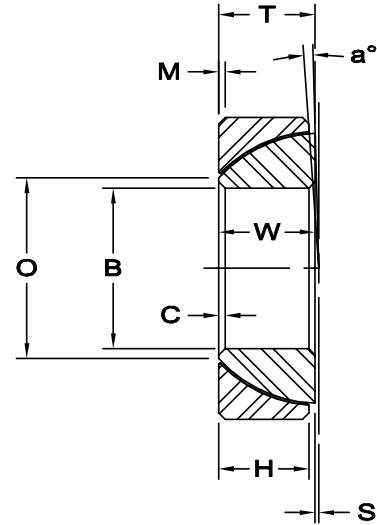
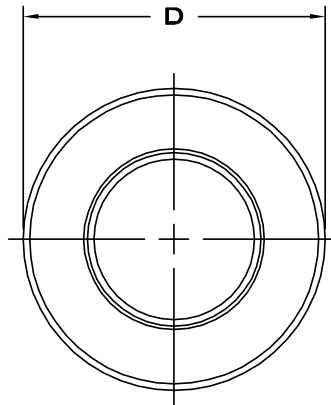

## LUBRICATION

Self lubricating PTFE liner.

BEARING NO.	DIMENSIONS IN MILLIMETERS												a° Misalign. Angle	Static Thrust Load Capacity kN	Approx. Brg. Wt. Grams
	B Bore Dia.		D Race Dia.		W Ball Width		H Race Width		T Ref.	Spherical Dia. Ref.	S Loc. Sphere Dia.	C.M Ball, Race Cmfr. Min.			
	Max.	Min.	Max.	Min.	Max.	Min.	Max.	Min.							
GAC25T	25.000	24.988	47.000	46.986	15.00	14.76	14.00	13.76	15.00	42.00	.60	1.0	2.5	225	148
GAC28T	28.000	27.988	52.000	51.984	15.00	14.76	15.00	14.70	16.00	47.00	1.00	1.0	2	270	186
GAC30T	30.000	29.988	55.000	54.984	17.00	16.76	15.00	14.70	17.00	49.50	1.30	1.0	4.5	285	208
GAC32T	32.000	31.988	58.000	57.984	17.00	16.76	16.00	15.70	17.00	52.00	2.00	1.0	2	320	241
GAC35T	35.000	34.988	62.000	61.984	18.00	17.76	16.00	15.70	18.00	55.50	2.10	1.0	4	340	268
GAC40T	40.000	39.988	68.000	67.984	19.00	18.76	17.00	16.70	19.00	62.00	2.80	1.0	3.5	400	327
GAC45T	45.000	44.988	75.000	74.984	20.00	19.76	18.00	17.70	20.00	68.50	3.50	1.0	3	470	416
GAC50T	50.000	49.988	80.000	79.984	20.00	19.76	19.00	18.70	20.00	74.00	4.30	1.0	1.5	540	455
GAC55T	55.000	54.985	90.000	89.982	23.00	22.70	20.00	19.60	23.00	82.00	5.00	1.1	4	630	645
GAC60T	60.000	59.985	95.000	94.982	23.00	22.70	21.00	20.60	23.00	88.50	5.70	1.1	2.5	710	714
GAC65T	65.000	64.985	100.000	99.982	23.00	22.70	22.00	21.60	23.00	93.50	6.50	1.1	1	790	759
GAC70T	70.000	69.985	110.000	109.982	25.00	24.70	23.00	22.60	25.00	102.00	7.20	1.1	2	900	1,040
GAC75T	75.000	74.985	115.000	114.982	25.00	24.70	24.00	23.60	25.00	107.00	7.90	1.1	1	980	1,120
GAC80T	80.000	79.985	125.000	124.980	29.00	28.70	25.50	25.00	29.00	115.00	8.60	1.1	3.5	1,120	1,540
GAC85T	85.000	84.980	130.000	129.980	29.00	28.60	26.50	26.00	29.00	122.00	9.40	1.1	2	1,240	1,610
GAC90T	90.000	89.980	140.000	139.980	32.00	31.60	28.00	27.50	32.00	128.50	10.10	1.5	3.5	1,380	2,090
GAC95T	95.000	94.980	145.000	144.980	32.00	31.60	29.50	29.00	32.00	135.00	10.80	1.5	2	1,530	2,220
GAC100T	100.000	99.980	150.000	149.980	32.00	31.60	31.00	30.50	32.00	141.00	11.60	1.5	.5	1,680	2,340
GAC105T	105.000	104.980	160.000	159.975	35.00	34.60	32.50	32.00	35.00	148.00	12.30	2.0	2	1,850	2,930
GAC110T	110.000	109.980	170.000	169.975	38.00	37.60	34.00	33.50	38.00	155.00	13.00	2.0	3	2,020	3,680
GAC120T	120.000	119.980	180.000	179.975	38.00	37.60	37.00	36.50	38.00	168.00	14.50	2.0	.5	2,390	3,970
GAC130T	130.000	129.975	200.000	199.970	45.00	44.50	43.00	42.40	45.00	188.00	18.00	2.5	1	3,110	5,920
GAC140T	140.000	139.975	210.000	209.970	45.00	44.50	43.00	42.40	45.00	198.00	19.00	2.5	1	3,270	6,330
GAC150T	150.000	149.975	225.000	224.970	48.00	47.50	46.00	45.40	48.00	211.00	20.00	3.0	1	3,730	8,010
GAC160T	160.000	159.975	240.000	239.970	51.00	50.50	49.00	48.40	51.00	225.00	20.00	3.0	1	4,240	9,790
GAC170T	170.000	169.975	260.000	259.965	57.00	56.50	55.00	54.30	57.00	246.00	21.00	3.0	1	5,200	12,300
GAC180T	180.000	179.975	280.000	279.965	64.00	63.50	61.00	60.30	64.00	260.00	21.00	3.0	1	6,100	17,400
GAC190T	190.000	189.970	290.000	289.965	64.00	63.40	62.00	61.30	64.00	275.00	26.00	3.0	.5	6,560	18,200
GAC200T	200.000	199.970	310.000	309.965	70.00	69.40	66.00	65.30	70.00	290.00	26.00	3.0	1.5	7,360	23,800



# FRACTURED RACE\* BEARINGS INTERCHANGE GUIDE

\*Also known as a split race bearings or light series bearings

timkenaurorabearing.com • Fax 630-859-0971

Aurora	IKO	INA	RBC	SKF	Torrington
GEZ X ES	SBB X	GE W ZO	B X -L	GEZ V ES	U SF X
GE Y ES	GE Y ES	GE Y DO	MB Y	GE Y ES	Y FS Y*
GEZ X ET-2RS			B X FSS	GEZ V TE-2RS	U SFL X
GE Y ET-2RS	GE Y EC-2RS	GE Y UK-2RS	MB Y FSS	GE Y TE-2RS	
GEG Y ES	GE Y GS	GE Y FO	MBH Y**	GEH Y ES	Y FSH Y*
GEEW Y ES		GE Y LO	MB Y -E	GEG Y ES	
GEWZ X ES			B X -EL	GEZM V ES	
GAC Y S		GE Y SX	MB Y -SA		
GACZ X S			B X -SA	GAZ V SA	U SBT X
GAC Y T		GE Y SW		GAC Y F	
Seals: -2 RS	-2 RS	-2 RS	SS	-2 RS	TT, SS

U = Approximate bore in inches. (ex. 5 = .5", 15 = 1.5")

V = Below 1", Bore in 1/16". Above 1" bore in whole inch + fraction in 1/16" (ex. 8 = 1/2", 108 = 1 1/2")

W = Bore is nearest metric equivalent for inch size. (ex. 12 = .5", .5" = 12.7 mm.)

X = Bore in 1/16". (ex. 8 = 1/2", 1/2" = 8/16")

Y = Bore in mm. (ex. 20 = 20mm.)

Y\* = OD in mm.

Y\*\* = Bore in mm. + bore of next size part offered (ex. 2025 = 20mm. bore, 25mm is bore of next larger size part offered)

Table to be used as a reference guide. Ultimate interchangeability should be determined by comparing relevant manufacturers specifications.

## Fractured Race Bearings Interchange

Manufacturer	Inch	Metric	For seals, add	Inch, PTFE lined	Metric, PTFE lined	Metric PTFE lined
Aurora	GEZ X ES	GE Y ES	2RS	GEZ X ET-2RS	GE Y ET-2RS	GE Y C
Alinabal	CBB X B2					
Askubal		GE Y	2RS		GE X D2RS	GE X D
FAG		GE Y ES	2RS			GE Y DE.5
Fluro		GE Y E	2RS			
Hunger	GE Y		H-A		GE Y HW-A	
IKO	SBB X	GE Y ES	2RS		GE X EC-2RS	
INA/Elges	GE W ZO	GE Y DO	2RS		GE X UK-2RS	GE X UK
National	GEZ W ES	GE Y ES				
NMB	ABB X S	SBH Y S	ZZ			
NTN	SA2 X B	SA1 Y B	SS			
RBC	B X L	MB Y	SS	B X FSS	MB Y FSS	
SKF	GEZ X ES	GE Y ES	2RS	GEZ X TE-2RS	GE X TE-2RS	GE X C
THK		SA1 Y B	UU			
Torrington	U SF X					

# HB SERIES

Ball Bearing, Self-aligning Rod Ends

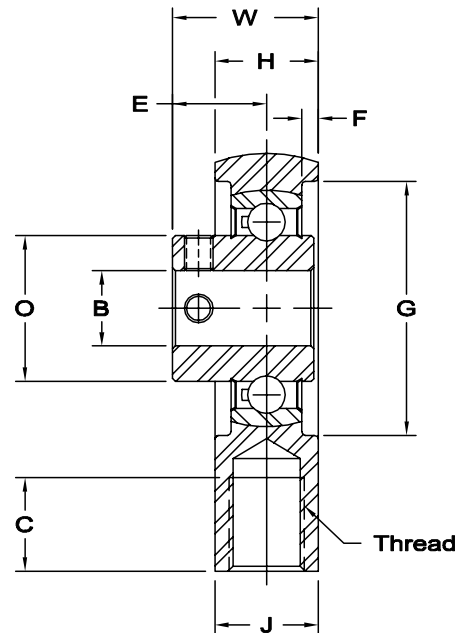
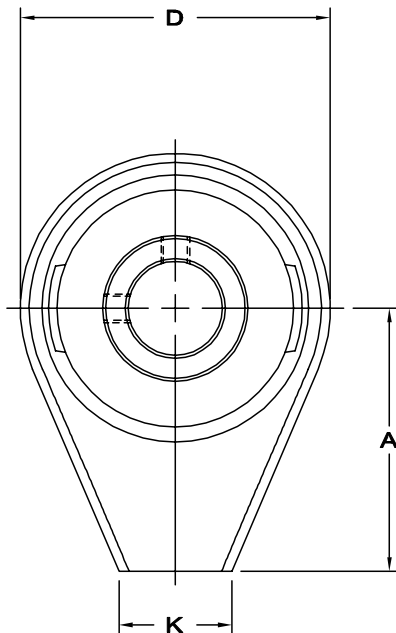

**HOUSING MATERIAL -  
DUCTILE IRON**

timkenaurorabearing.com • Fax 630-859-0971

Consult our Engineering Department for load ratings and RPM information.

Shaft Dia.	Unit No.	DIMENSIONS IN INCHES												Approx. Brg. Wt. Lbs.	
		A	B Ref.	C	D	E	F	G	H	J	K	O	W		Thread Size
1/2"	HB-8	1 3/4	.500	5/8	2 1/16	5/8	7/64	1 11/16	11/16	11/16	3/4	.961	31/32	1/2-20 UNF	.63
5/8"	HB-10	1 3/4	.625	5/8	2 1/16	5/8	7/64	1 11/16	11/16	11/16	3/4	.961	31/32	1/2-20 UNF	.63
3/4"	HB-12	1 13/16	.750	1/2	2 1/4	23/32	3/32	1 15/16	3/4	3/4	13/16	1.165	1 3/32	1/2-13 UNC	.75

\*Check for availability.

Shaft Dia.	Unit No.	DIMENSIONS IN MILLIMETERS												Approx. Brg. Wt. Lbs.	
		A	B Ref.	C	D	E	F	G	H	J	K	O	W		Thread Size
1/2"	HB-8	44.45	12.70	15.88	52.37	15.88	2.78	42.86	17.46	17.46	19.05	24.41	24.61	1/2-20 UNF	284
5/8"	HB-10	44.45	15.88	15.88	52.37	15.88	2.78	42.86	17.46	17.46	19.05	24.41	24.61	1/2-20 UNF	284
3/4"	HB-12	46.04	19.05	12.70	57.15	18.26	2.38	49.21	19.05	19.05	20.64	29.59	27.78	1/2-13 UNC	341

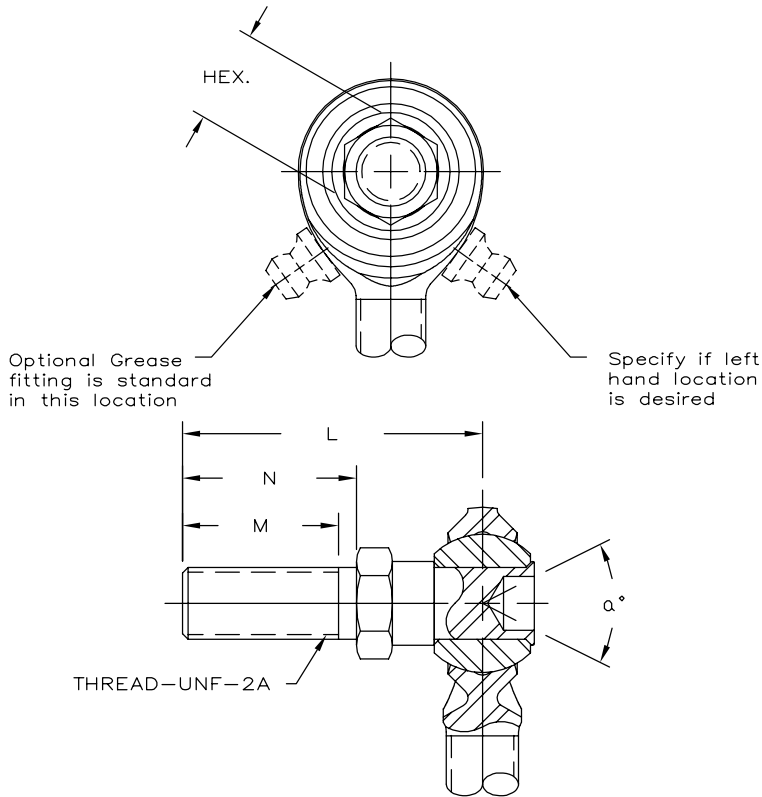

**EX CM-8SZ**

**NOTES:**

1. Stud configuration is shown as a 2-piece male, but is also available in 2-piece female, most 3-piece male and female configurations, and the AIB, MIB, and SIB spherical bearing configurations. Studs are specifically not available in the HXAM and COM series.
2. Grease fittings are not available on the CM-3S, CM-4S, CM-5S, or CW-3S rod ends. Units are supplied without grease fittings. When grease fittings are required, specify by adding suffix Z or F. (ex.: CM-8SZ). See page 78 for lubrication fitting information.
3. The standard grease fitting location (right hand location) is configured with the stud facing away from you while holding the rod end. If fitting must be oriented on the opposite side of the rod end, specify the left hand location.
4. The ultimate radial static load capacity is based on the shear strength of the stud.
5. Thread UNC-2A
6. Stud sizes 3 through 12 are normally stocked, size 2 and 16 are available on special order. Rod ends with studs installed are normally only stocked in the CM/CB series male rod ends, and CW/CG female rod ends. Studs are installed in rod ends of other series on a special order basis.
7. Standard stud material is low-carbon steel, protective coated for corrosion resistance.

STUD SIZE	DIMENSIONS IN INCHES					CM/CW Series Total Misalign. Angle	VCM/VCW, CM/CW-ET Series Total Misalign. Angle	3 - Piece Total Misalign. Angle	Ultimate Radial Static Load Capacity Lbs.
	L ± .015	N ± .010	M Ref.	Hex Size Ref.	Thread UNF-2A				
2	.875	.500	.437	.250	.1380-32	N/A	N/A	47	100
3	1.000	.500	.437	.312	.1900-32	45	N/A	40	240
4	1.031	.562	.500	.375	.2500-28	43	N/A	34	442
5	1.219	.687	.593	.438	.3125-24	46	38	39	715
6	1.562	.906	.812	.500	.3750-24	45	38	36	1,014
7	1.750	1.062	.937	.562	.4375-20	44	38	39	1,269
8	2.000	1.125	1.000	.625	.5000-20	48	38	42	1,668
10	2.500	1.500	1.375	.750	.6250-18	54	45	45	1,943
12	3.000	1.812	1.625	.875	.7500-16	50	42	40	2,841
16	3.562	2.000	1.750	1.250	1.0000-12	N/A	N/A	42	8,178

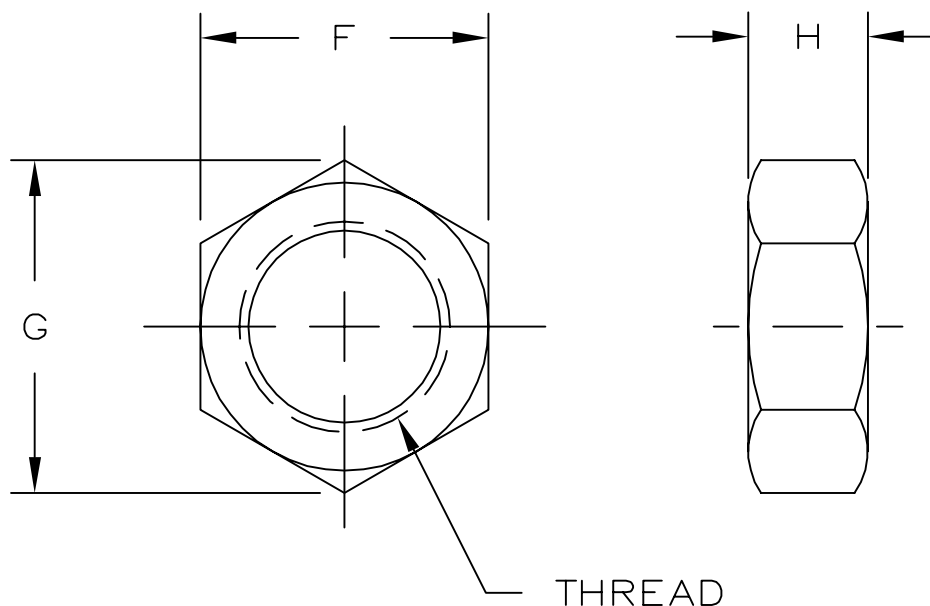

### NOTES:

1. Right hand threaded jam nuts are zinc plated clear and left hand threaded jam nuts are zinc plated yellow.

JAM NUT NO.		DIMENSIONS IN INCHES			
Right Hand Thread	Left Hand Thread	Thread UNF-2B	F Ref.	G Ref.	H Ref.
JNR-0332	JNL-0332	.1900-32	.375	.417	.125
JNR-0428	JNL-0428	.2500-28	.438	.505	.156
JNR-0524	JNL-0524	.3125-24	.500	.577	.188
JNR-0624	JNL-0624	.3750-24	.562	.650	.219
JNR-0720	JNL-0720	.4375-20	.688	.794	.250
JNR-0820	JNL-0820	.5000-20	.750	.866	.312
JNR-1018	JNL-1018	.6250-18	.938	1.083	.375
JNR-1216	JNL-1216	.7500-16	1.125	1.299	.422
JNR-1414	JNL-1414	.8750-14	1.312	1.516	.484
JNR-1612	JNL-1612	1.0000-12	1.500	1.732	.547
JNR-1614	JNL-1614	1.0000-14	1.500	1.732	.547
JNR-2012	JNL-2012	1.2500-12	1.875	2.165	.719
JNR-2412	JNL-2412	1.5000-12	2.250	2.598	.844
JNR-3212	JNL-3212	2.0000-12	3.125	3.608	1.094

JAM NUT NO.		DIMENSIONS IN MILLIMETERS			
Right Hand Thread	Left Hand Thread	Thread -6H	F Ref.	G Ref.	H Ref.
JNR-M5	JNL-M5	M5X0.8	8.00	9.24	2.70
JNR-M6	JNL-M6	M6X1.0	10.00	11.55	3.20
JNRF-M8	JNLF-M8	M8X1.0	13.00	15.01	4.00
JNR-M8	JNL-M8	M8X1.25	13.00	15.01	4.00
JNRF-M10	JNLF-M10	M10X1.25	16.00	18.48	5.00
JNR-M10	JNL-M10	M10X1.5	16.00	18.48	5.00
JNRF-M12	JNLF-M12	M12X1.25	18.00	20.78	6.00
JNR-M12	JNL-M12	M12X1.75	18.00	20.78	6.00
JNRF-M14	JNLF-M14	M14X1.5	21.00	24.25	7.00
JNR-M14	JNL-M14	M14X2.0	21.00	24.25	7.00
JNRF-M16	JNLF-M16	M16X1.5	24.00	27.71	8.00
JNR-M16	JNL-M16	M16X2.0	24.00	27.71	8.00
JNRF-M20	JNLF-M20	M20X1.5	30.00	34.64	10.00
JNR-M20	JNL-M20	M20X2.5	30.00	34.64	10.00
JNR-M25	JNL-M25	M24X2.0	36.00	41.57	12.00
JNR-M30	JNL-M30	M30X2.0	46.00	53.12	15.00

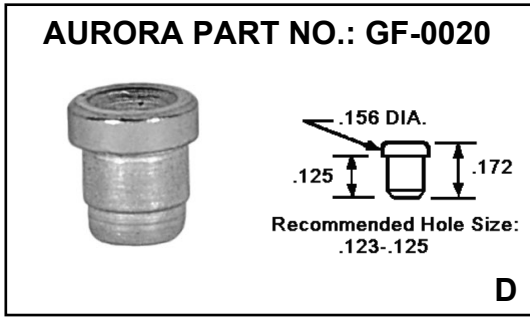
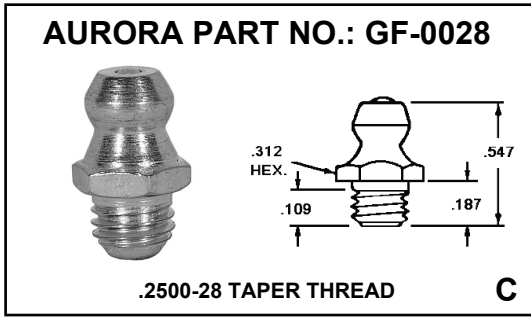
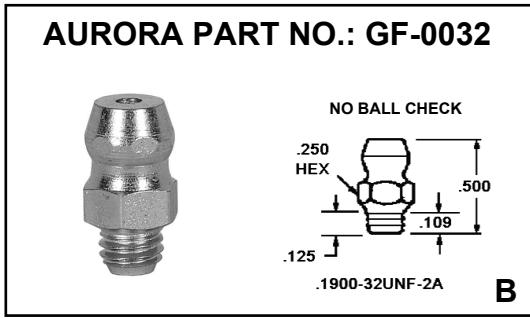
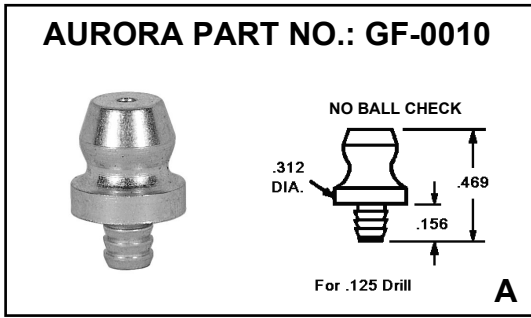

### Standard Inch Catalog Grease Fitting Chart

Rod End Series	Bore Sizes										
	2	3	4	5	6	7	8	10	12	14	16 & Above
AM Series	N/A	A	A	B	B <sub>2</sub>	B <sub>2</sub>	B <sub>2</sub>	B <sub>2</sub>	B <sub>2</sub>	B <sub>2</sub>	C
AW Series	N/A	B <sub>2</sub>	B <sub>2</sub>	B <sub>2</sub>	B <sub>2</sub>	B <sub>2</sub>	B <sub>2</sub>	B <sub>2</sub>	B <sub>2</sub>	B <sub>2</sub>	C
CM Series	N/A	N/A	N/A	N/A	A	A	A	B	B	B	N/A
CW Series	N/A	N/A	B <sub>2</sub>	B <sub>2</sub>	B <sub>2</sub>	B <sub>2</sub>	B <sub>2</sub>	B <sub>2</sub>	B <sub>2</sub>	N/A	N/A
CAM Series	N/A	N/A	N/A	N/A	A	A	A	B	B	B	N/A
HXAM Series	N/A	A	A	B	B	B	B <sub>2</sub>	B <sub>2</sub>	B <sub>2</sub>	N/A	N/A
KM Series	N/A	A	A	B	B <sub>2</sub>	B <sub>2</sub>	B <sub>2</sub>	B <sub>2</sub>	B <sub>2</sub>	B <sub>2</sub>	C
KW Series	N/A	B <sub>2</sub>	B <sub>2</sub>	B <sub>2</sub>	B <sub>2</sub>	B <sub>2</sub>	B <sub>2</sub>	B <sub>2</sub>	B <sub>2</sub>	B <sub>2</sub>	C
MM Series	N/A	A	A	B	B <sub>2</sub>	B <sub>2</sub>	B <sub>2</sub>	B <sub>2</sub>	B <sub>2</sub>	B <sub>2</sub>	C
MW Series	N/A	B <sub>2</sub>	B <sub>2</sub>	B <sub>2</sub>	B <sub>2</sub>	B <sub>2</sub>	B <sub>2</sub>	B <sub>2</sub>	B <sub>2</sub>	B <sub>2</sub>	C
RAM Series	N/A	A	A	B	B <sub>2</sub>	B <sub>2</sub>	B <sub>2</sub>	B <sub>2</sub>	B <sub>2</sub>	N/A	N/A
RXAM Series	N/A	A	A	B	B <sub>2</sub>	B <sub>2</sub>	B <sub>2</sub>	B <sub>2</sub>	N/A	N/A	N/A
SM Series	N/A	A	A	B	B <sub>2</sub>	B <sub>2</sub>	B <sub>2</sub>	B <sub>2</sub>	B <sub>2</sub>	B <sub>2</sub>	C
SW Series	N/A	B <sub>2</sub>	B <sub>2</sub>	B <sub>2</sub>	B <sub>2</sub>	B <sub>2</sub>	B <sub>2</sub>	B <sub>2</sub>	B <sub>2</sub>	B <sub>2</sub>	C
XM Series	N/A	A	A	B	B <sub>2</sub>	B <sub>2</sub>	B <sub>2</sub>	B <sub>2</sub>	B <sub>2</sub>	N/A	N/A
XW Series	N/A	B <sub>2</sub>	B <sub>2</sub>	B <sub>2</sub>	B <sub>2</sub>	B <sub>2</sub>	B <sub>2</sub>	B <sub>2</sub>	B <sub>2</sub>	N/A	N/A
XAM Series	N/A	A	A	B	B <sub>2</sub>	B <sub>2</sub>	B <sub>2</sub>	B <sub>2</sub>	B <sub>2</sub>	N/A	N/A

### Standard Metric Catalog Grease Fitting Chart

Rod End Series	Bore Sizes											
	3	5	6	8	10	12	14	16	18	20	22	25 & Above
AM Series	N/A	A	A	B	B <sub>2</sub>	B <sub>2</sub>	B <sub>2</sub>	B <sub>2</sub>	B <sub>2</sub>	B <sub>2</sub>	B <sub>2</sub>	C
AW Series	N/A	B <sub>2</sub>	B <sub>2</sub>	B <sub>2</sub>	B <sub>2</sub>	B <sub>2</sub>	B <sub>2</sub>	B <sub>2</sub>	B <sub>2</sub>	B <sub>2</sub>	B <sub>2</sub>	C
CM Series	N/A	N/A	N/A	N/A	A	A	A	B	B	B	N/A	N/A
CW Series	N/A	N/A	B <sub>2</sub>	B <sub>2</sub>	B <sub>2</sub>	B <sub>2</sub>	B <sub>2</sub>	B <sub>2</sub>	B <sub>2</sub>	B <sub>2</sub>	N/A	N/A
KM Series	N/A	A	A	B	B <sub>2</sub>	B <sub>2</sub>	B <sub>2</sub>	B <sub>2</sub>	B <sub>2</sub>	B <sub>2</sub>	B <sub>2</sub>	C
KW Series	N/A	B <sub>2</sub>	B <sub>2</sub>	B <sub>2</sub>	B <sub>2</sub>	B <sub>2</sub>	B <sub>2</sub>	B <sub>2</sub>	B <sub>2</sub>	B <sub>2</sub>	B <sub>2</sub>	C
MM Series	N/A	A	A	B	B <sub>2</sub>	B <sub>2</sub>	B <sub>2</sub>	B <sub>2</sub>	B <sub>2</sub>	B <sub>2</sub>	B <sub>2</sub>	C
MW Series	N/A	B <sub>2</sub>	B <sub>2</sub>	B <sub>2</sub>	B <sub>2</sub>	B <sub>2</sub>	B <sub>2</sub>	B <sub>2</sub>	B <sub>2</sub>	B <sub>2</sub>	B <sub>2</sub>	C

**NOTES:**

1. Flush type grease fitting (figure D) may be substituted for the zerk type grease fittings shown in figures A and B when properly specified with "F" suffix in the part number. (ex. AM-6F or AM-M10F)
2. GF-0028 Zerk type grease fitting (Figure C) with ball check may be substituted when properly specified with "-28". (ex.: AW-6Z-28 or AW-M10Z-28) The substitution of GF-0028 may affect the usable thread depth of some female rod ends.

The Timken Aurora Bearing Company's reputation for designing and producing high quality commercial rod ends and spherical bearings grew extensively from the inception of the organization. Timken Aurora Bearing continually expanded its product lines, and its range grew to allow the firm to service virtually every major industrial market.

In those markets, Timken Aurora Bearing consistently demonstrated a reputation for furnishing reliable product. As a result, firms sought help from Aurora engineers and manufacturing specialists to solve difficult application problems.

Because of the skills demonstrated by Aurora in the commercial bearing market, Aurora's expertise attracted the attention of the military specification market.

By the mid 1980's Timken Aurora Bearing's total quality reputation was recognized by the aircraft airframe industry, and the Timken Aurora Bearing Company was solicited by airframe manufacturers to build products for them to their specifications. Similar recognition occurred in the land based and naval defense marketplace.

This prompted a decision to seriously enter the aircraft and defense markets, and by 1988 Timken Aurora Bearing Company was soliciting business on a controlled basis, in order to insure consistent customer satisfaction. These efforts resulted in a smooth and successful entry into the aircraft and defense marketplaces.

Building upon this success, the Timken Aurora Bearing Company then decided to aggressively enter the military specification bearing marketplace. Aurora now offers 14 standard lines of SAE specification rod end, spherical and journal bearings, presented on the following pages. These bearings utilize Auroras AT3200, Aurora's exclusive PTFE liner system, qualified to the AS81820 Type A specification. These bearing series all are listed on the Qualified Products List (QPL) for military specification bearing products.

In addition, Aurora offers two standard rod end bearing lines as utilized in the general aviation field. These are manufactured under the same quality and SPC systems as the military approved bearings. Dimensions and configurations follow established industry conventions. Total traceability's are maintained through manufacturing up to and including shipping.

The growth of Aurora's standard military specification product offerings, as well as the extensive and diverse commercial/ industrial line has allowed manufactures to often achieve solutions with catalog items. Aurora's specialists are regularly called upon to work in partnership with customers to develop custom designed products for sophisticated aerospace and defense applications





# ANC-T & ANC-TG SPHERICAL BEARINGS

Narrow - SAE Series AS14101 (Grooved)

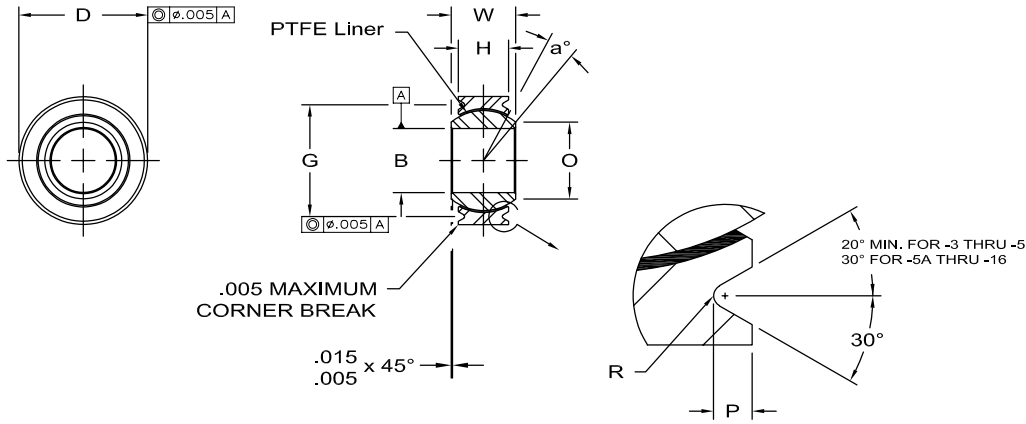

**Race** - 17-4 PH stainless steel (AMS 5643), heat treated.

**Ball** - 440C stainless steel (AMS 5630), heat treated.

**Liner** - AT 3200 bearing liner, permanently bonded to race I.D., qualified to SAE-AS81820 Type A

FOR STAKING INFORMATION, SEE PAGES 115-117.

SAE NO.		AURORA NO.		DIMENSIONS IN INCHES								
GROOVED	PLAIN	GROOVED	PLAIN	B	D	W	H	O	P	G	R ‡	Ball
				+ .0000 - .0005	+ .0000 - .0005	+ .000 - .002	±.005	MIN.	+ .000 - .010	+ .000 - .008	+ .002 - .005	Dia. Ref.
MS14101-3	MS14104-3	ANC-3TG	ANC-3T	.1900	.5625	.281	.218	.293	.025	.500	.010	.406
MS14101-4	MS14104-4	ANC-4TG	ANC-4T	.2500	.6562	.343	.250	.364	.025	.594	.010	.500
MS14101-5	MS14104-5	ANC-5TG	ANC-5T	.3125	.7500	.375	.281	.419	.035	.650	.010	.562
MS14101-5A	-	ANC-5TGA	-	.3125	.7500	.375	.281	.419	.035	.660	.010	.562
MS14101-6	MS14104-6	ANC-6TG	ANC-6T	.3750	.8125	.406	.312	.475	.035	.712	.015	.625
MS14101-7	MS14104-7	ANC-7TG	ANC-7T	.4375	.9062	.437	.343	.530	.035	.806	.015	.687
MS14101-8	MS14104-8	ANC-8TG	ANC-8T	.5000	1.0000	.500	.390	.600	.055	.876	.015	.781
MS14101-9	MS14104-9	ANC-9TG	ANC-9T	.5625	1.0937	.562	.437	.670	.055	.970	.015	.875
MS14101-10	MS14104-10	ANC-10TG	ANC-10T	.6250	1.1875	.625	.500	.739	.055	1.063	.015	.968
MS14101-12	MS14104-12	ANC-12TG	ANC-12T	.7500	1.4375	.750	.593	.920	.055	1.313	.015	1.187
MS14101-14	MS14104-14	ANC-14TG	ANC-14T	.8750	1.5625	.875	.703	.980	.055	1.438	.015	1.312
MS14101-16	MS14104-16	ANC-16TG	ANC-16T	1.0000	1.7500	1.000	.797	1.118	.055	1.626	.015	1.500

## NOTES:

- Temperature Range: -65°F To +325°F (-54°C to +163°C)
- Standard fit bearings are void of any "radial" or "axial" clearance
- AT 3200 Bearing Liner System is qualified for procurement under SAE-AS81820 Type A
- Spherical Bearings listed are manufactured to conform to the dimensions, materials, and configurations of SAE-AS14101 and SAE-AS14104 and are approved for procurement under this specification.
- Non-standard material, dimensional, or configuration specifications (not per the SAE Aerospace Standard Specification) can be provided. Consult factory for additional information.
- The Spherical Bearings listed are available in non PTFE lined, metal on metal configuration (not per the SAE Aerospace Standard Specification), as well as with alternate Timken Aurora Bearing PTFE liner systems. Consult factory for additional information.
- ‡ Sizes -3, -4, -5, and -5A "R" = +.000, -.005
- Consult factory for full specifications. Weight calculations listed are valid for standard outside diameter parts only.

Effective August 21st, 2023, the Naval Air Warfare Center Aircraft Division (NAWCAD) has disapproved Timken Aurora's qualification status for SAE-AS81820 and SAE-AS81935 specifications. Timken Aurora is working diligently to get requalified.



# ANC-T & ANC-TG SPHERICAL BEARINGS

Narrow - SAE Series AS14104 (Plain)

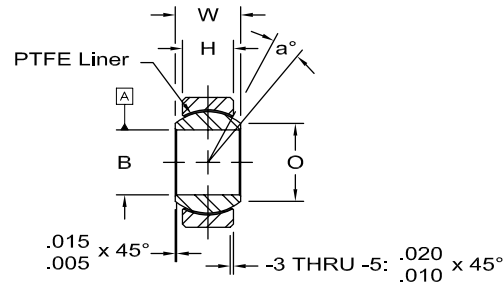
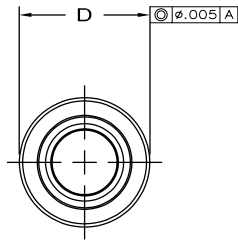

**Race** - 17-4 PH stainless steel (AMS 5643), heat treated.

**Ball** - 440C stainless steel (AMS 5630), heat treated.

**Liner** - AT 3200 bearing liner, permanently bonded to race I.D., qualified to SAE-AS81820. Type A

-6 THRU -10: .030 x 45°  
.020

-12 THRU -16: .040 x 45°  
.030

a° Misalign. Angle Ref.	STATIC LIMIT LOAD		Oscillating Load Lbs.	STANDARD FIT		"K" FIT		Approx. Brg. Wt. Lbs.	SAE NO.		AURORA NO.	
	Radial Lbs.	Axial Lbs.		No Load Rotational Breakway Torque Max. In Lbs.	No Load Rotational Breakway Torque Max. In Lbs.	Radial Clearance Max.	Axial Clearance Max.		GROOVED	PLAIN	GROOVED	PLAIN
10	3,975	150	1,500	.25-5.0	0.5	.0007	.0028	.020	MS14101-3	MS14104-3	ANC-3TG	ANC-3T
10	6,040	430	3,320	.25-5.0	0.5	.0007	.0028	.020	MS14101-4	MS14104-4	ANC-4TG	ANC-4T
10	8,750	700	5,460	.25-8.0	1.0	.0007	.0028	.030	MS14101-5	MS14104-5	ANC-5TG	ANC-5T
10	8,750	700	5,460	.25-8.0	1.0	.0007	.0028	.030	MS14101-5A	-	ANC-5TGA	-
9	10,540	1,100	6,600	.25-8.0	1.0	.0007	.0028	.040	MS14101-6	MS14104-6	ANC-6TG	ANC-6T
8	13,200	1,400	8,050	.25-8.0	1.0	.0007	.0028	.050	MS14101-7	MS14104-7	ANC-7TG	ANC-7T
8	17,900	2,100	10,400	.25-8.0	1.0	.0007	.0028	.070	MS14101-8	MS14104-8	ANC-8TG	ANC-8T
8	23,200	3,680	13,000	.25-8.0	1.0	.0007	.0028	.090	MS14101-9	MS14104-9	ANC-9TG	ANC-9T
8	30,500	4,720	16,450	.25-8.0	1.0	.0007	.0028	.120	MS14101-10	MS14104-10	ANC-10TG	ANC-10T
8	46,400	6,750	23,600	.25-8.0	1.0	.0007	.0028	.210	MS14101-12	MS14104-12	ANC-12TG	ANC-12T
8	62,200	9,350	30,250	.25-12.0	2.0	.0010	.0040	.270	MS14101-14	MS14104-14	ANC-14TG	ANC-14T
9	82,200	12,160	38,000	.25-12.0	2.0	.0010	.0040	.390	MS14101-16	MS14104-16	ANC-16TG	ANC-16T

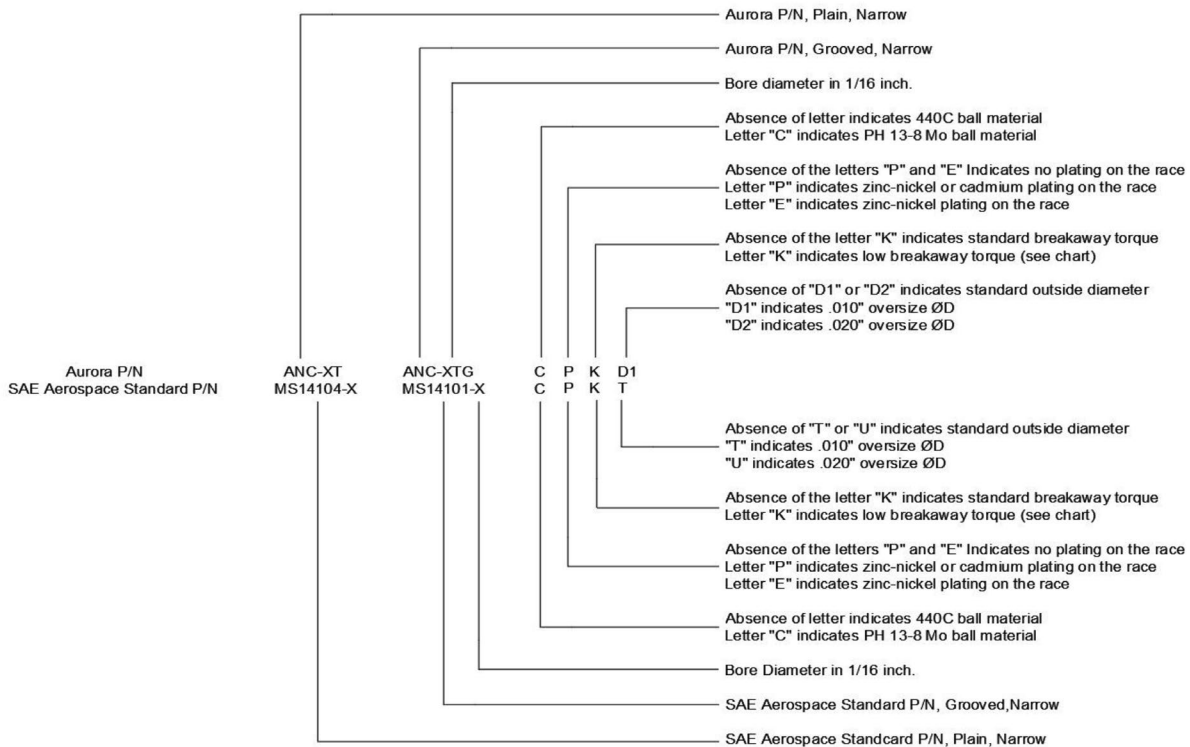

Effective August 21st, 2023, the Naval Air Warfare Center Aircraft Division (NAWCAD) has disapproved Timken Aurora's qualification status for SAE-AS81820 and SAE-AS81935 specifications. Timken Aurora is working diligently to get requalified.

timkenaurorabearing.com • Fax 630-859-0971



# AWC-T & AWC-TG SPHERICAL BEARINGS

Wide - SAE Series AS14103 (Grooved)

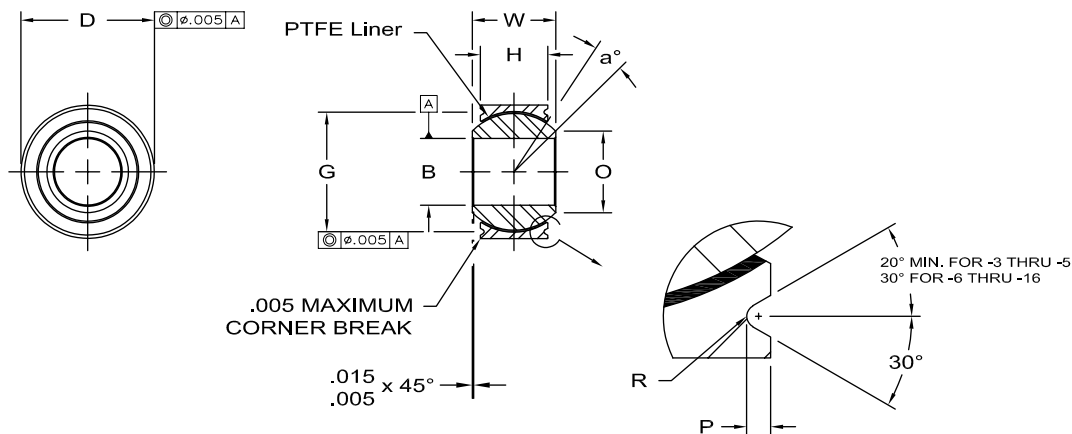

**Race** - 17-4 PH stainless steel (AMS 5643), heat treated.

**Ball** - 440C stainless steel (AMS 5630), heat treated.

**Liner** - AT 3200 bearing liner, permanently bonded to race I.D., qualified to SAE-AS81820 Type A

FOR STAKING INFORMATION, SEE PAGES 115-117.

SAE NO.		AURORA NO.		DIMENSIONS IN INCHES								
GROOVED	PLAIN	GROOVED	PLAIN	B + .0000 - .0005	D + .0000 - .0005	W + .000 - .002	H ± .005	O MIN.	P + .000 - .010	G + .000 - .008	R ‡ + .002 - .005	Ball Dia. Ref.
MS14103-3	MS14102-3	AWC-3TG	AWC-3T	.1900	.6250	.437	.327	.300	.025	.563	.010	.531
MS14103-4	MS14102-4	AWC-4TG	AWC-4T	.2500	.6250	.437	.327	.300	.025	.563	.010	.531
MS14103-5	MS14102-5	AWC-5TG	AWC-5T	.3125	.6875	.437	.317	.360	.025	.625	.010	.593
MS14103-6	MS14102-6	AWC-6TG	AWC-6T	.3750	.8125	.500	.406	.466	.035	.712	.015	.687
MS14103-7	MS14102-7	AWC-7TG	AWC-7T	.4375	.9375	.562	.442	.537	.035	.837	.015	.781
MS14103-7A	-	AWC-7TGA	-	.4375	.9062	.562	.442	.537	.035	.806	.015	.781
MS14103-8	MS14102-8	AWC-8TG	AWC-8T	.5000	1.0000	.625	.505	.607	.035	.900	.015	.875
MS14103-9	MS14102-9	AWC-9TG	AWC-9T	.5625	1.1250	.687	.536	.721	.035	1.025	.015	1.000
MS14103-10	MS14102-10	AWC-10TG	AWC-10T	.6250	1.1875	.750	.567	.747	.035	1.087	.015	1.062
MS14103-12	MS14102-12	AWC-12TG	AWC-12T	.7500	1.3750	.875	.630	.845	.055	1.251	.015	1.250
MS14103-14	MS14102-14	AWC-14TG	AWC-14T	.8750	1.6250	.875	.755	.995	.055	1.501	.015	1.375
MS14103-16	MS14102-16	AWC-16TG	AWC-16T	1.0000	2.1250	1.375	1.005	1.269	.055	2.001	.015	1.875

## NOTES:

- Temperature Range: -65°F To +325°F (-54°C to +163°C)
- Standard fit bearings are void of any "radial" or "axial" clearance
- AT3200 Bearing Liner System is qualified for procurement under SAE-AS81820 Type A
- Spherical Bearings listed are manufactured to conform to the dimensions, materials, and configurations of SAE-AS14102 and SAE-AS14103 and are approved for procurement under this specification.
- Non-standard material, dimensional, or configuration specifications (not per the SAE Aerospace Standard Specification) can be provided. Consult factory for additional information.
- The Spherical Bearings listed are available in non PTFE lined, metal on metal configuration (not per the SAE Aerospace Standard Specification), as well as with alternate Timken Aurora Bearing PTFE liner systems. Consult factory for additional information.
- ‡ Sizes -3, -4, -5, and -5A "R" = +.000, -.005
- Consult factory for full specifications. Weight calculations listed are valid for standard outside diameter parts only.

Effective August 21st, 2023, the Naval Air Warfare Center Aircraft Division (NAWCAD) has disapproved Timken Aurora's qualification status for SAE-AS81820 and SAE-AS81935 specifications. Timken Aurora is working diligently to get requalified.

# AWC-T & AWC-TG SPHERICAL BEARINGS

Wide - SAE Series AS14102 (Plain)

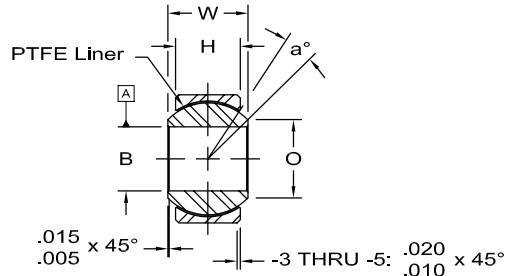
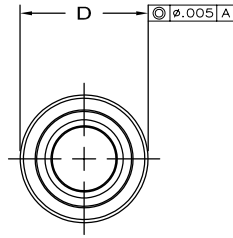

**Race** - 17-4 PH stainless steel (AMS 5643), heat treated.

**Ball** - 440C stainless steel (AMS 5630), heat treated.

**Liner** - AT 3200 bearing liner, permanently bonded to race I.D., qualified to SAE-AS81820 Type A

-6 THRU -10: .030 x 45°  
.020

-12 THRU -16: .040 x 45°  
.030

a° Misalign. Angle Ref.	STATIC LIMIT LOAD		Oscillating Load Lbs.	STANDARD FIT		"K" FIT		Approx. Brg. Wt. Lbs.	SAE NO.		AURORA NO.	
	Radial Lbs.	Axial Lbs.		No Load Rotational Breakway Torque Max. In Lbs.	No Load Rotational Breakway Torque Max. In Lbs.	Radial Clearance Max.	Axial Clearance Max.		GROOVED	PLAIN	GROOVED	PLAIN
15	2,500	1,770	4,900	.25-5.0	0.5	.0007	.0021	.031	MS14103-3	MS14102-3	AWC-3TG	AWC-3T
15	5,500	1,770	4,900	.25-5.0	0.5	.0007	.0021	.031	MS14103-4	MS14102-4	AWC-4TG	AWC-4T
14	9,400	1,640	6,050	.25-8.0	1.0	.0007	.0021	.035	MS14103-5	MS14102-5	AWC-5TG	AWC-5T
8	13,700	2,630	8,310	.25-8.0	1.0	.0007	.0021	.060	MS14103-6	MS14102-6	AWC-6TG	AWC-6T
10	20,700	3,650	11,750	.25-8.0	1.0	.0007	.0021	.080	MS14103-7	MS14102-7	AWC-7TG	AWC-7T
10	19,700	3,650	11,750	.25-8.0	1.0	.0007	.0021	.080	MS14103-7A	-	AWC-7TGA	-
9	21,400	4,970	14,950	.25-8.0	1.0	.0007	.0021	.100	MS14103-8	MS14102-8	AWC-8TG	AWC-8T
10	26,600	5,370	18,100	.25-8.0	1.0	.0007	.0021	.135	MS14103-9	MS14102-9	AWC-9TG	AWC-9T
12	29,000	6,130	20,250	.25-8.0	1.0	.0007	.0021	.160	MS14103-10	MS14102-10	AWC-10TG	AWC-10T
13	37,000	7,730	26,200	.25-8.0	1.0	.0007	.0021	.240	MS14103-12	MS14102-12	AWC-12TG	AWC-12T
6	65,200	10,800	33,600	.25-12.0	2.0	.0010	.0030	.350	MS14103-14	MS14102-14	AWC-14TG	AWC-14T
12	104,000	19,300	56,250	.25-12.0	2.0	.0010	.0030	.970	MS14103-16	MS14102-16	AWC-16TG	AWC-16T

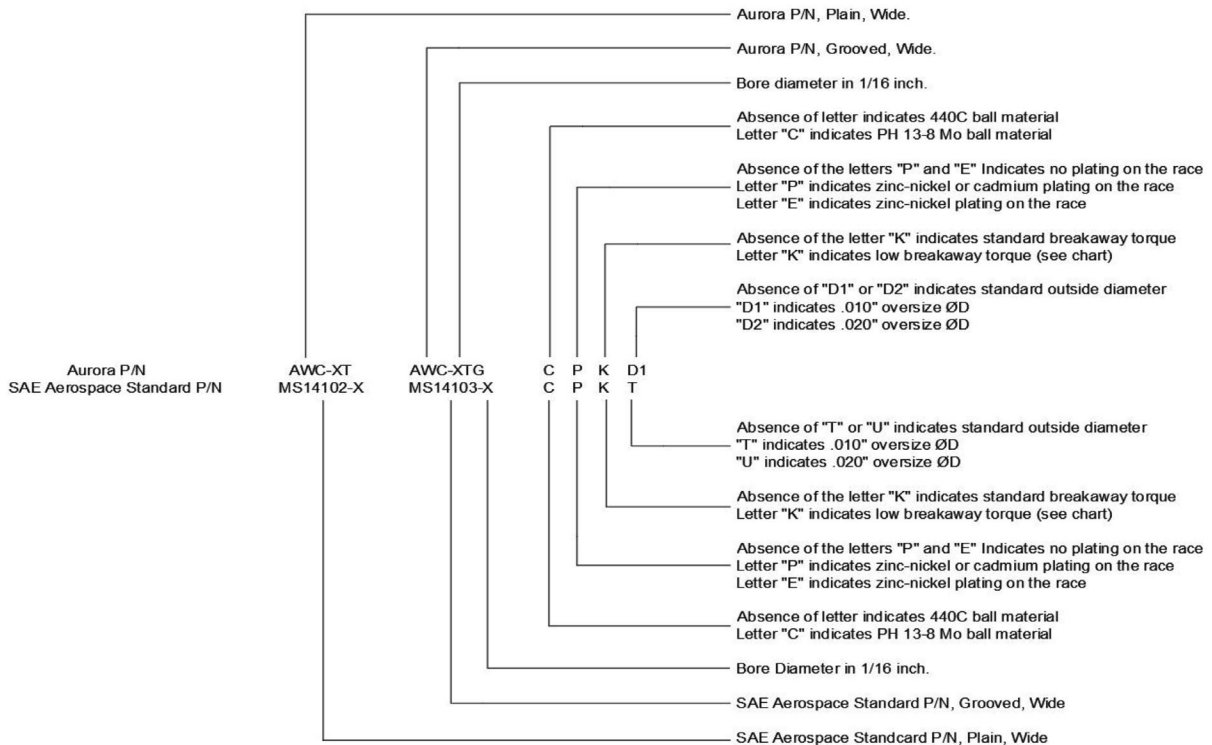

Effective August 21st, 2023, the Naval Air Warfare Center Aircraft Division (NAWCAD) has disapproved Timken Aurora's qualification status for SAE-AS81820 and SAE-AS81935 specifications. Timken Aurora is working diligently to get requalified.

timkenaurorabearing.com • Fax 630-859-0971



# ASM-T & ASB-T MALE ROD ENDS

SAE Series AS81935/1 (Right Hand) & AS81935/1 (Left Hand)

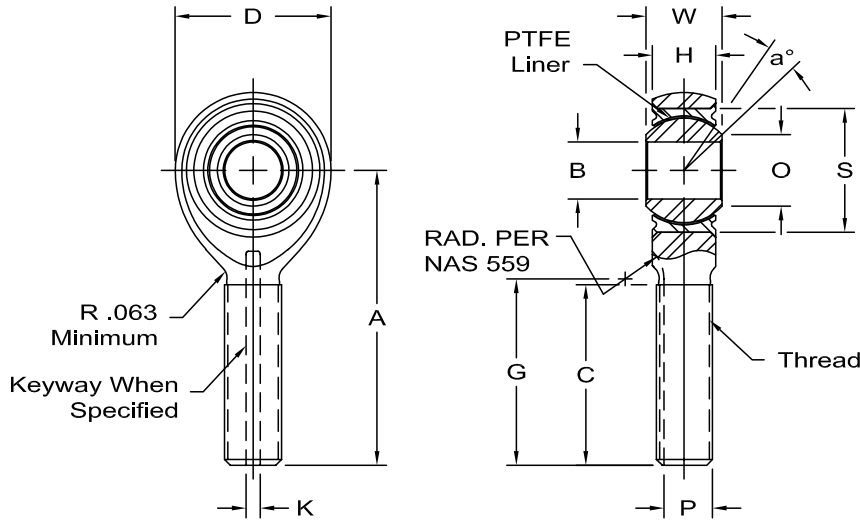

**Body** - 4340 Alloy Steel (AMS 6415), heat treated, cadmium plated.

**Race** - 17-4 PH stainless steel (AMS 5643), heat treated

**Ball** - 440C stainless steel (AMS 5630), heat treated

**Liner** - AT3200 bearing liner, permanently bonded to race I.D., qualified to SAE-AS81820 Type A

timkenaurorabearing.com • Fax 630-859-0971

SAE NO.		AURORA NO.		DIMENSIONS IN INCHES										
Right Hand	Left Hand	Right Hand	Left Hand	B +.0000 -.0005	W +.000 -.002	H ± .005	A ± .010	D ± .010	O Min.	S Max. Housing I.D.	Ball Dia. Ref.	G +.000 -.020	K +.005 -.000	P +.000 -.005
M81935/1-03	M81935/1-03L	ASM-3T	ASB-3T	.1900	.437	.337	1.562	.806	.30	.6250	.531	.980	.062	.268
M81935/1-04	M81935/1-04L	ASM-4T	ASB-4T	.2500	.437	.337	1.562	.806	.30	.6250	.531	.980	.062	.268
M81935/1-05	M81935/1-05L	ASM-5T	ASB-5T	.3125	.437	.327	1.875	.900	.36	.6875	.593	1.270	.062	.268
M81935/1-06	M81935/1-06L	ASM-6T	ASB-6T	.3750	.500	.416	1.938	1.025	.47	.8125	.687	1.235	.093	.319
M81935/1-07	M81935/1-07L	ASM-7T	ASB-7T	.4375	.562	.452	2.125	1.150	.54	.9062	.781	1.402	.093	.383
M81935/1-08	M81935/1-08L	ASM-8T	ASB-8T	.5000	.625	.515	2.438	1.337	.61	1.0000	.875	1.589	.093	.445
M81935/1-10	M81935/1-10L	ASM-10T	ASB-10T	.6250	.750	.577	2.625	1.525	.75	1.1875	1.062	1.683	.125	.541
M81935/1-12	M81935/1-12L	ASM-12T	ASB-12T	.7500	.875	.640	2.875	1.775	.85	1.3750	1.250	1.808	.125	.663
M81935/1-14	M81935/1-14L	ASM-14T	ASB-14T	.8750	.875	.765	3.375	2.025	1.00	1.6250	1.375	2.121	.156	.777
M81935/1-16	M81935/1-16L	ASM-16T	ASB-16T	1.0000	1.375	1.015	4.125	2.775	1.27	2.1250	1.875	2.464	.187	1.136

### NOTES:

- Temperature Range: -65°F To +325°F (-54°C to +163°C)
- Keyway, when specified, is compatible with locking devices: AS81935/3 for sizes - 03 thru -08, and NAS 513 for sizes -10 thru -16
- AT 3200 Bearing Liner System is qualified for procurement under SAE-AS81820 Type A
- Rod End Bearings listed are manufactured to conform to the dimensions, materials, and configurations of SAE-AS81935/1 and are approved for procurement under this specification
- Non-standard material, dimensional, or configurations (not per the SAE Aerospace Standard Specification) can be provided. Consult factory for additional information
- The Rod End Bearings listed are available in non PTFE lined, metal on metal configuration (not per the SAE Aerospace Standard Specification), as well as with alternate Timken Aurora Bearing PTFE liner systems. Consult factory for additional information

Effective August 21st, 2023, the Naval Air Warfare Center Aircraft Division (NAWCAD) has disapproved Timken Aurora's qualification status for SAE-AS81820 and SAE-AS81935 specifications. Timken Aurora is working diligently to get requalified.

# ASM-T & ASB-T MALE ROD ENDS

SAE Series AS81935/1 (Right Hand) & AS81935/1 (Left Hand)

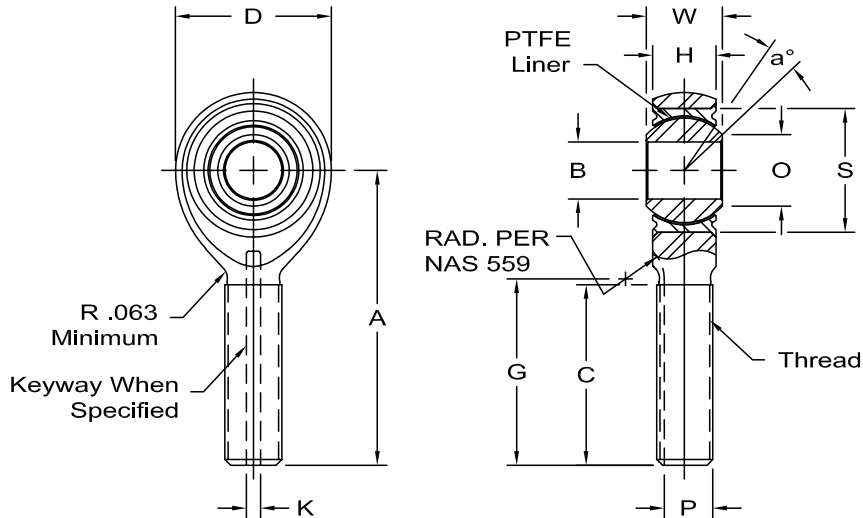

**Body** - 4340 Alloy Steel (AMS 6415), heat treated, cadmium plated.

**Race** - 17-4 PH stainless steel (AMS 5643), heat treated

**Ball** - 440C stainless steel (AMS 5630), heat treated

**Liner** - AT3200 bearing liner, permanently bonded to race I.D., qualified to SAE-AS81820 Type A

C ± .031	Thread UNJF-3A	a° Misalign. Angle Min.	Approx. Brg. Wt. Lbs.	Ult. Static Radial Load Lbs.	Fatigue Load Lbs.	Axial Proof Load Lbs.	No Load Rotational Breakaway Torque In-Lbs.		SAE NO.		AURORA NO.	
							Min.	Max.	Right Hand	Left Hand	Right Hand	Left Hand
.968	5/16-24	15	.072	2,360	1,470	1,000	.5	6	M81935/1-03	M81935/1-03L	ASM-3T	ASB-3T
.968	5/16-24	15	.072	4,860	2,380	1,000	.5	6	M81935/1-04	M81935/1-04L	ASM-4T	ASB-4T
1.187	5/16-24	14	.087	7,180	2,770	1,100	1	15	M81935/1-05	M81935/1-05L	ASM-5T	ASB-5T
1.187	3/8-24	8	.136	8,550	3,570	1,660	1	15	M81935/1-06	M81935/1-06L	ASM-6T	ASB-6T
1.281	7/16-20	10	.183	12,000	4,800	1,850	1	15	M81935/1-07	M81935/1-07L	ASM-7T	ASB-7T
1.468	1/2-20	9	.278	19,500	7,680	2,040	1	15	M81935/1-08	M81935/1-08L	ASM-8T	ASB-8T
1.562	5/8-18	12	.424	21,900	9,180	2,430	1	15	M81935/1-10	M81935/1-10L	ASM-10T	ASB-10T
1.687	3/4-16	13	.639	29,300	11,600	2,810	1	15	M81935/1-12	M81935/1-12L	ASM-12T	ASB-12T
2.000	7/8-14	6	.963	34,500	13,100	3,320	1	24	M81935/1-14	M81935/1-14L	ASM-14T	ASB-14T
2.343	1 1/4-12	12	2.546	80,300	30,400	4,340	1	24	M81935/1-16	M81935/1-16L	ASM-16T	ASB-16T

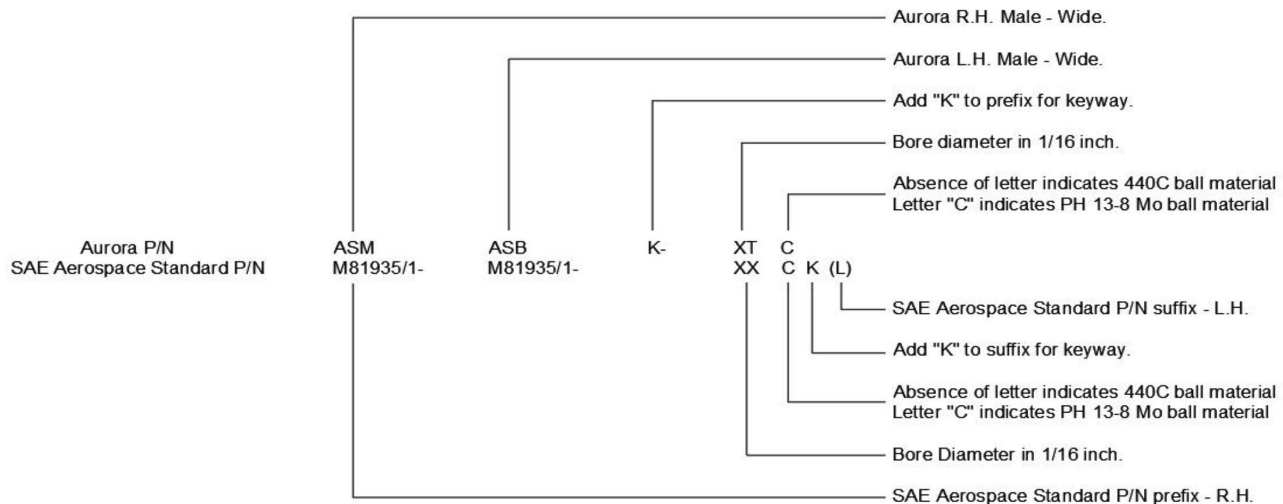

Effective August 21st, 2023, the Naval Air Warfare Center Aircraft Division (NAWCAD) has disapproved Timken Aurora's qualification status for SAE-AS81820 and SAE-AS81935 specifications. Timken Aurora is working diligently to get requalified.



# ASW-T & ASG-T FEMALE ROD ENDS

SAE Series AS81935/2 (Right Hand) & AS81935/2 (Left Hand)

timkenaurorabearing.com • Fax 630-859-0971

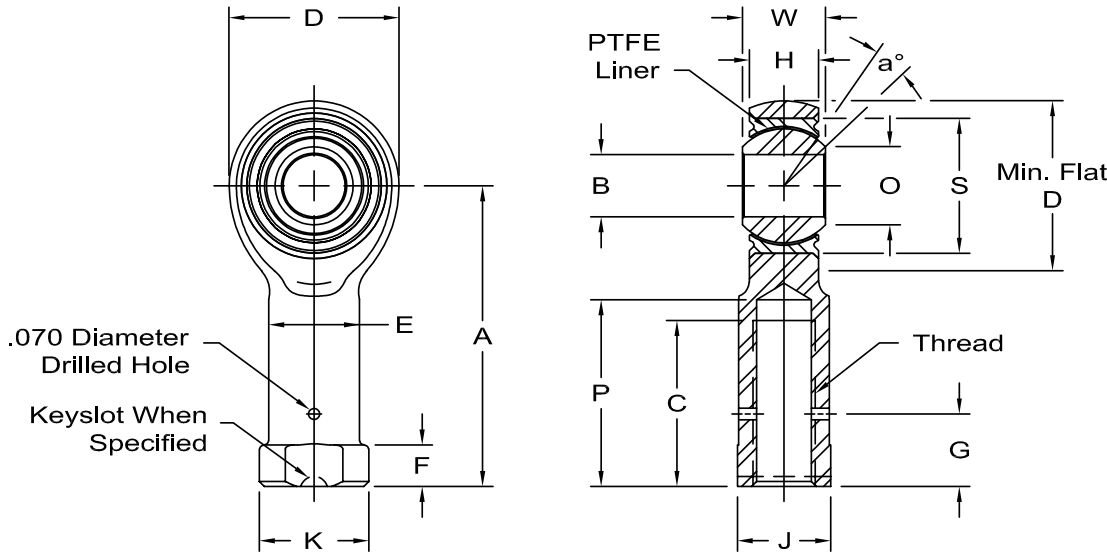

**Body** - 4340 alloy steel (AMS 6415), heat treated, cadmium plated

**Race** - 17-4 PH stainless steel (AMS 5643), heat treated

**Ball** - 440C stainless steel (AMS 5630), heat treated

**Liner** - AT3200 bearing liner, permanently bonded to race I.D., qualified to SAE-AS81820 Type A

SAE NO.		AURORA NO.		DIMENSIONS IN INCHES															
Right Hand	Left Hand	Right Hand	Left Hand	B +.0000 -.0005	W +.000 -.002	H ±.005	A ±.010	D ±.010	O Min.	S Max. Housing I.D.	E ±.010	K Ref. Dia.	J ±.010	G +.020	F +.010 -.062	Ball Dia. Ref.	P Max.	C Min.	Thread UNJF-3B
M81935/2-03	M81935/2-03L	ASW-3T	ASG-3T	.1900	.437	.337	1.375	.806	.30	.6250	.422	.500	.437	.188	.375	.531	.875	.750	5/16-24
M81935/2-04	M81935/2-04L	ASW-4T	ASG-4T	.2500	.437	.337	1.469	.806	.30	.6250	.422	.500	.437	.188	.375	.531	.875	.750	5/16-24
M81935/2-05	M81935/2-05L	ASW-5T	ASG-5T	.3125	.437	.327	1.625	.900	.36	.6875	.485	.580	.500	.250	.437	.593	1.000	.875	3/8-24
M81935/2-06	M81935/2-06L	ASW-6T	ASG-6T	.3750	.500	.416	1.812	1.025	.47	.8125	.547	.660	.562	.250	.437	.687	1.125	1.000	3/8-24
M81935/2-07	M81935/2-07L	ASW-7T	ASG-7T	.4375	.562	.452	2.000	1.150	.54	.9062	.610	.720	.625	.250	.500	.781	1.250	1.125	7/16-20
M81935/2-08	M81935/2-08L	ASW-8T	ASG-8T	.5000	.625	.515	2.250	1.337	.61	1.0000	.735	.880	.750	.250	.562	.875	1.375	1.250	1/2-20
M81935/2-10	M81935/2-10L	ASW-10T	ASG-10T	.6250	.750	.577	2.500	1.525	.75	1.1875	.860	1.020	.875	.375	.687	1.062	1.500	1.375	5/8-18
M81935/2-12	M81935/2-12L	ASW-12T	ASG-12T	.7500	.875	.640	2.875	1.775	.85	1.3750	.985	1.160	1.000	.375	.812	1.250	1.750	1.625	3/4-16
M81935/2-14	M81935/2-14L	ASW-14T	ASG-14T	.8750	.875	.765	3.375	2.025	1.00	1.6250	1.110	1.300	1.125	.500	.937	1.375	2.062	1.875	7/8-14
M81935/2-16	M81935/2-16L	ASW-16T	ASG-16T	1.0000	1.375	1.015	4.125	2.775	1.27	2.1250	1.688	2.020	1.750	.563	1.312	1.875	2.312	2.125	1 1/4-12

### NOTES:

- Temperature Range: -65°F To +325°F (-54°C to +163°C)
- Keyslot, when specified, is compatible with locking devices: AS81935/3 for sizes -03 thru -08, and AS14277, NAS513, and NAS1193 for sizes -10 thru -16
- Keyslot designation "K" sizes -03 thru -08 (rounded slot) and sizes -10 thru -16 (square slot)
- Keyslot for sizes -03 thru -06 have 2 slots oriented perpendicular to the rod end hoop face (see diagram)
- Keyslot for sizes -07 thru -16 have 4 slots, 2 slots oriented perpendicular to the rod end hoop face (see diagram)
- Rod End Bearings listed are manufactured to conform to the dimensions, materials, and configurations of SAE-AS81935/2 and are approved for procurement under this specification
- Non-standard material, dimensional, or configuration specifications (not per the SAE Aerospace Standard Specification) can be provided. Consult factory for additional information
- The Rod End Bearings listed are available in non PTFE lined, metal on metal configuration (not per the SAE Aerospace Standard Specification), as well as with alternate Timken Aurora Bearing PTFE liner systems. Consult factory for additional information

Effective August 21st, 2023, the Naval Air Warfare Center Aircraft Division (NAWCAD) has disapproved Timken Aurora's qualification status for SAE-AS81820 and SAE-AS81935 specifications. Timken Aurora is working diligently to get requalified.

# ASW-T & ASG-T FEMALE ROD ENDS

SAE Series AS81935/2 (Right Hand) & AS81935/2 (Left Hand)



timkenaurorabearing.com • Fax 630-859-0971

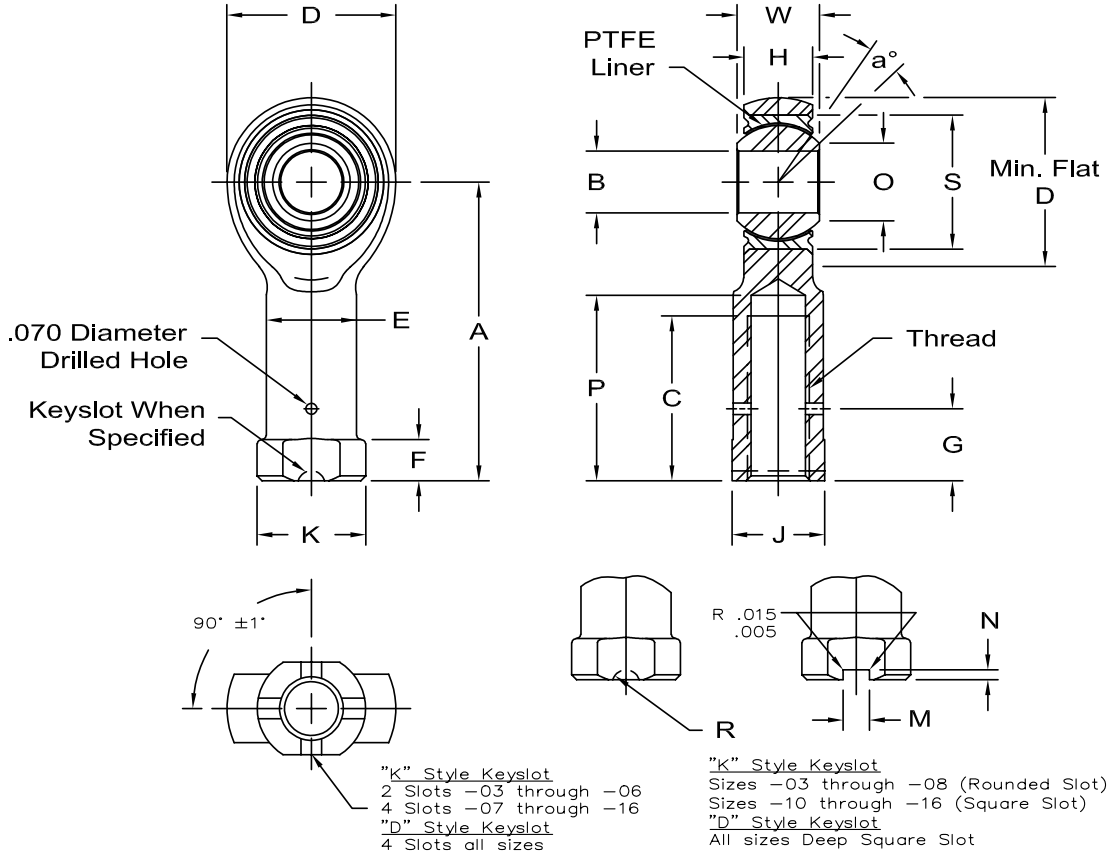

DIMENSIONS IN INCHES					a° Misalign. Angle Ref.	Approx. Brg. Wt. Lbs.	Ult. Static Radial Load Lbs.	Fatigue Load Lbs.	Axial Proof Load Lbs.	No Load Rotational Breakaway Torque In-Lbs.		SAE NO.		AURORA NO.	
"K" STYLE KEYSLOT			"D" STYLE KEYSLOT							Min.	Max.	Right Hand	Left Hand	Right Hand	Left Hand
-	.055 - .065	.078	.062	.110	15	.080	2,360	1,470*	1,000	.5	6	M81935/2-03	M81935/2-03L	ASW-3T	ASG-3T
-	.055 - .065	.078	.062	.110	15	.084	4,860	2,380	1,000	.5	6	M81935/2-04	M81935/2-04L	ASW-4T	ASG-4T
-	.055 - .065	.078	.093	.110	14	.102	7,180	3,020	1,100	1	15	M81935/2-05	M81935/2-05L	ASW-5T	ASG-5T
-	.055 - .065	.078	.093	.110	8	.161	8,550	3,570	1,660	1	15	M81935/2-06	M81935/2-06L	ASW-6T	ASG-6T
-	.055 - .065	.078	.093	.110	10	.212	12,000	4,800	1,850	1	15	M81935/2-07	M81935/2-07L	ASW-7T	ASG-7T
-	.055 - .065	.078	.093	.110	9	.325	19,500	8,260	2,040	1	15	M81935/2-08	M81935/2-08L	ASW-8T	ASG-8T
.125 - .130	.077 - .082	-	.125	.110	12	.481	21,900	9,180	2,430	1	15	M81935/2-10	M81935/2-10L	ASW-10T	ASG-10T
.125 - .130	.077 - .082	-	.125	.110	13	.673	29,300	11,600	2,810	1	15	M81935/2-12	M81935/2-12L	ASW-12T	ASG-12T
.156 - .161	.086 - .091	-	.156	.110	6	.959	34,500	13,100	3,320	1	24	M81935/2-14	M81935/2-14L	ASW-14T	ASG-14T
.187 - .192	.116 - .121	-	.187	.116	12	2.717	80,300	30,400	4,340	1	24	M81935/2-16	M81935/2-16L	ASW-16T	ASG-16T

\*Based on bolt bending fatigue strength 180,000 PSI

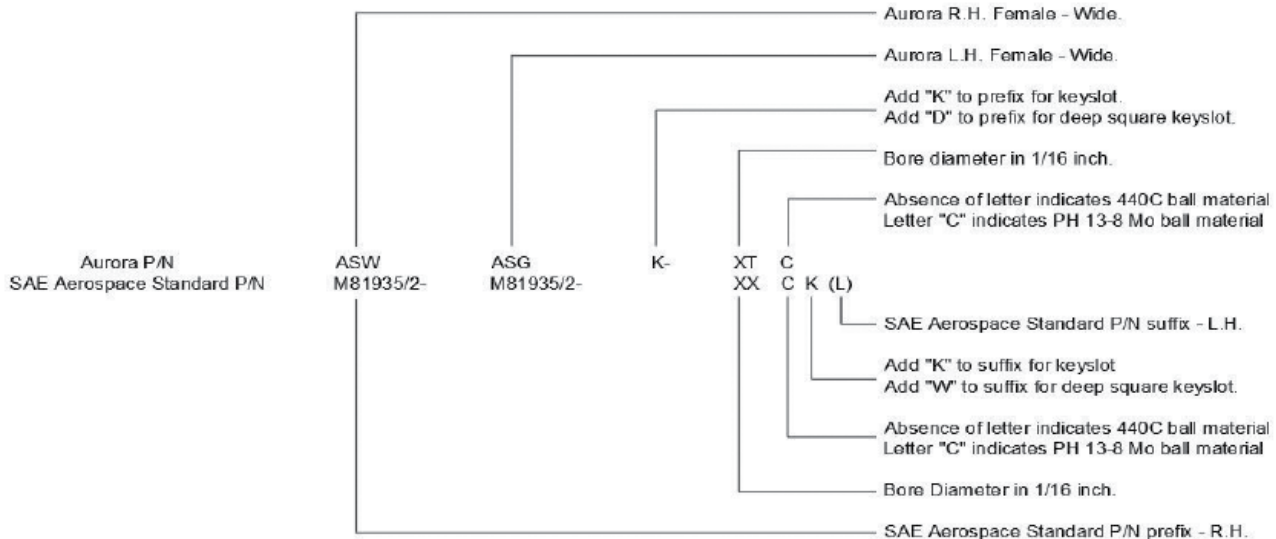

Effective August 21st, 2023, the Naval Air Warfare Center Aircraft Division (NAWCAD) has disapproved Timken Aurora's qualification status for SAE-AS81820 and SAE-AS81935 specifications. Timken Aurora is working diligently to get requalified.



# ATM-T & ATB-T MALE ROD ENDS

SAE Series AS81935/4 (Right Hand) & AS81935/4 (Left Hand)

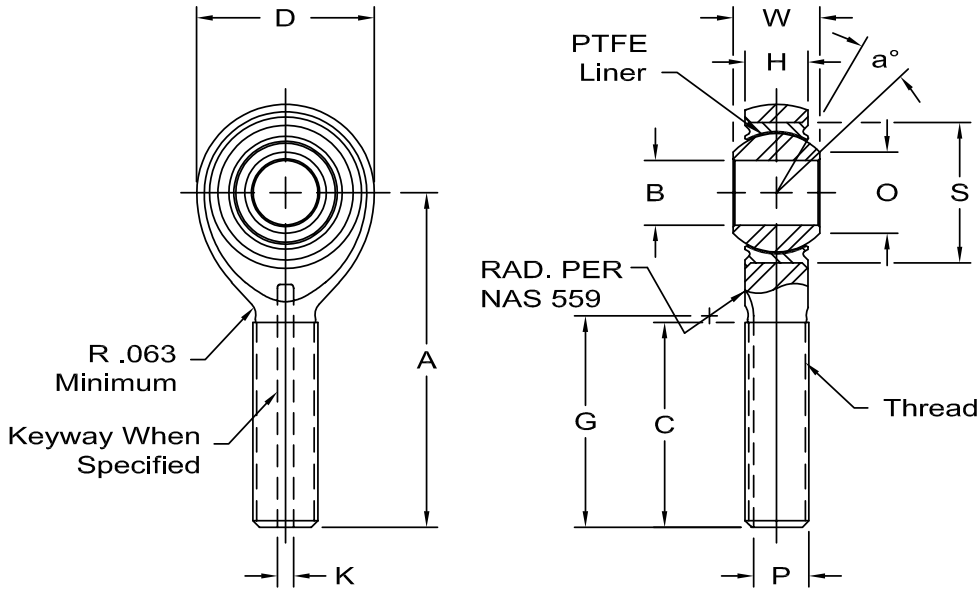

**Body** - 4340 Alloy Steel (AMS 6415), heat treated, cadmium plated.

**Race** - 17-4 PH stainless steel (AMS 5643), heat treated

**Ball** - 440C stainless steel (AMS 5630), heat treated

**Liner** - AT 3200 bearing liner, permanently bonded to race I.D., qualified to SAE-AS81820 Type A

timkenaurorabearing.com • Fax 630-859-0971

SAE NO.		AURORA NO.		DIMENSIONS IN INCHES										
Right Hand	Left Hand	Right Hand	Left Hand	B +.0000 -.0005	W +.000 -.002	H ± .005	A ± .010	D ± .010	O Min.	S Max. Housing I.D.	Ball Dia. Ref.	G ‡ +.000 -.020	K +.005 -.000	P +.000 -.005
M81935/4-03	M81935/4-03L	ATM-3T	ATB-3T	.1900	.281	.228	1.315	.680	.293	.5625	.406	.896	.062	.207
M81935/4-03BK†	M81935/4-03BKL†	ATMK-3TB	ATBK-3TB	.1900	.281	.228	1.315	.680	.293	.5625	.406	.876	.062	.207
M81935/4-04	M81935/4-04L	ATM-4T	ATB-4T	.2500	.343	.260	1.443	.827	.364	.6562	.500	.896	.062	.207
M81935/4-05	M81935/4-05L	ATM-5T	ATB-5T	.3125	.375	.291	1.948	.984	.419	.7500	.562	1.308	.062	.268
M81935/4-06	M81935/4-06L	ATM-6T	ATB-6T	.3750	.406	.322	2.030	1.131	.475	.8125	.625	1.308	.093	.319
M81935/4-07	M81935/4-07L	ATM-7T	ATB-7T	.4375	.437	.353	2.250	1.294	.530	.9062	.687	1.402	.093	.383
M81935/4-08	M81935/4-08L	ATM-8T	ATB-8T	.5000	.500	.400	2.544	1.459	.600	1.0000	.781	1.589	.093	.445
M81935/4-10	M81935/4-10L	ATM-10T	ATB-10T	.6250	.625	.510	2.832	1.763	.739	1.1875	.968	1.683	.125	.541
M81935/4-12	M81935/4-12L	ATM-12T	ATB-12T	.7500	.750	.603	3.193	2.140	.920	1.4375	1.187	1.808	.125	.663
M81935/4-14	M81935/4-14L	ATM-14T	ATB-14T	.8750	.875	.713	3.677	2.372	.980	1.5625	1.312	2.121	.156	.777
M81935/4-16	M81935/4-16L	ATM-16T	ATB-16T	1.0000	1.000	.807	3.968	2.681	1.118	1.7500	1.500	2.221	.156	.900

† M81935/4-03B is only valid with a keyway

‡ -03BK "G" +.000, -.040

### NOTES:

- Temperature Range: -65°F To +325°F (-54°C to +163°C)
- Keyway, when specified, is compatible with locking devices: AS81935/3 for sizes -03 thru -08, and NAS 513 for sizes -10 thru -16
- AT3200 Bearing Liner System is qualified for procurement under SAE-AS81820 Type A
- Rod End Bearings listed are manufactured to conform to the dimensions, materials, and configurations of SAE-AS81935/4 and are approved for procurement under this specification
- Non-standard material, dimensional, or configurations (not per the SAE Aerospace Standard Specification) can be provided. Consult factory for additional information
- The Rod End Bearings listed are available in non PTFE lined, metal on metal configuration (not per the SAE Aerospace Standard Specification), as well as with alternate Timken Aurora Bearing PTFE liner systems. Consult factory for additional information

Effective August 21st, 2023, the Naval Air Warfare Center Aircraft Division (NAWCAD) has disapproved Timken Aurora's qualification status for SAE-AS81820 and SAE-AS81935 specifications. Timken Aurora is working diligently to get requalified.



# ATM-T & ATB-T MALE ROD ENDS

SAE Series AS81935/4 (Right Hand) & AS81935/4 (Left Hand)

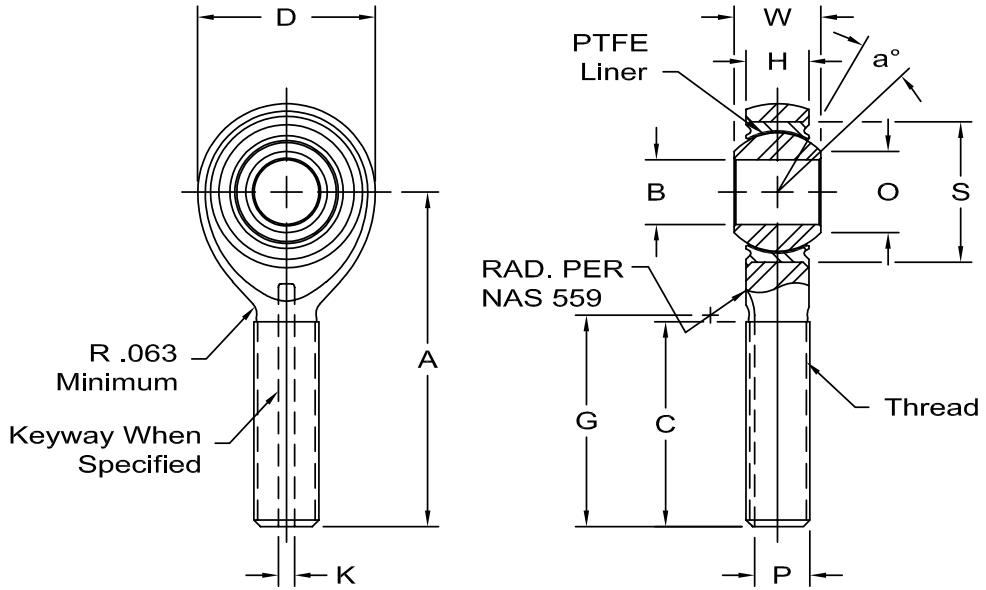

**Body** - 4340 Alloy Steel (AMS 6415), heat treated, cadmium plated.

**Race** - 17-4 PH stainless steel (AMS 5643), heat treated

**Ball** - 440C stainless steel (AMS 5630), heat treated

**Liner** - AT 3200 bearing liner, permanently bonded to race I.D., qualified to SAE-AS81820 Type A

C ± .031	Thread UNJF-3A	a° Misalign. Angle Min.	Approx. Brg. Wt. Lbs.	Ult. Static Radial Load Lbs.	Fatigue Load Lbs.	Axial Proof Load Lbs.	No Load Rotational Breakaway Torque In-Lbs.		SAE NO.		AURORA NO.	
							Min.	Max.	Right Hand	Left Hand	Right Hand	Left Hand
.775	1/4-28	10	.045	3,000	1,100	150	.5	6	M81935/4-03	M81935/4-03L	ATM-3T	ATB-3T
.775	1/4-28	10	.045	3,000	1,100	150	.5	6	M81935/4-03BK†	M81935/4-03BKL†	ATMK-3TB	ATBK-3TB
.775	1/4-28	10	.060	5,300	1,500	430	.5	6	M81935/4-04	M81935/4-04L	ATM-4T	ATB-4T
1.187	5/16-24	10	.100	8,600	2,400	700	1	15	M81935/4-05	M81935/4-05L	ATM-5T	ATB-5T
1.187	3/8-24	9	.135	13,000	3,600	1,100	1	15	M81935/4-06	M81935/4-06L	ATM-6T	ATB-6T
1.281	7/16-20	8	.200	17,800	5,000	1,400	1	15	M81935/4-07	M81935/4-07L	ATM-7T	ATB-7T
1.468	1/2-20	8	.285	24,200	6,800	2,040	1	15	M81935/4-08	M81935/4-08L	ATM-8T	ATB-8T
1.562	5/8-18	8	.505	38,500	10,800	2,430	1	15	M81935/4-10	M81935/4-10L	ATM-10T	ATB-10T
1.687	3/4-16	8	.830	56,600	16,000	2,940	1	15	M81935/4-12	M81935/4-12L	ATM-12T	ATB-12T
2.000	7/8-14	8	1.235	77,400	21,900	3,190	1	24	M81935/4-14	M81935/4-14L	ATM-14T	ATB-14T
2.100	1-12	9	1.725	101,400	28,600	3,570	1	24	M81935/4-16	M81935/4-16L	ATM-16T	ATB-16T

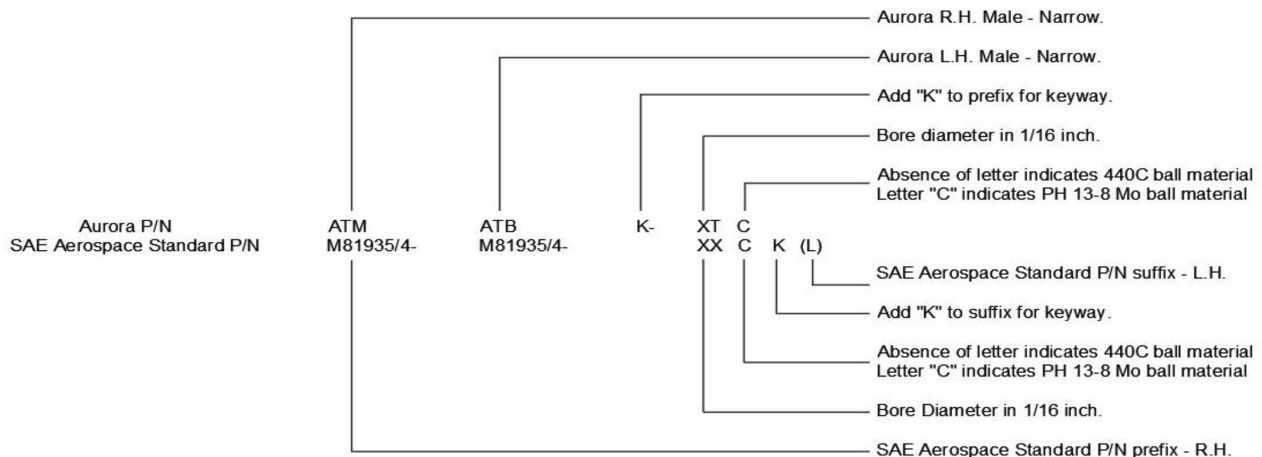

Effective August 21st, 2023, the Naval Air Warfare Center Aircraft Division (NAWCAD) has disapproved Timken Aurora's qualification status for SAE-AS81820 and SAE-AS81935 specifications. Timken Aurora is working diligently to get requalified.

timkenaurorabearing.com • Fax 630-859-0971



# ATW-T & ATG-T FEMALE ROD ENDS

SAE Series AS81935/5 (Right Hand) & AS81935/5 (Left Hand)

timkenaurorabearing.com • Fax 630-859-0971

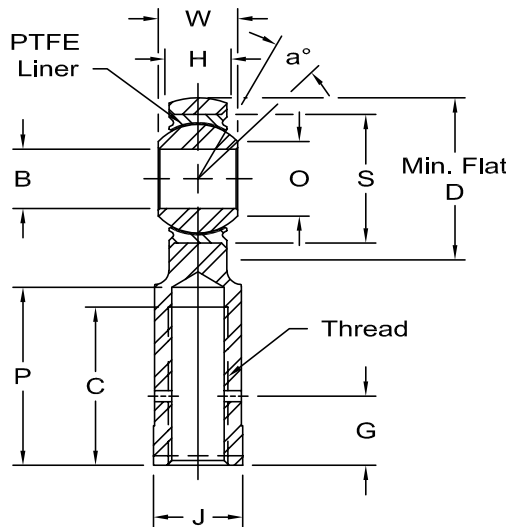
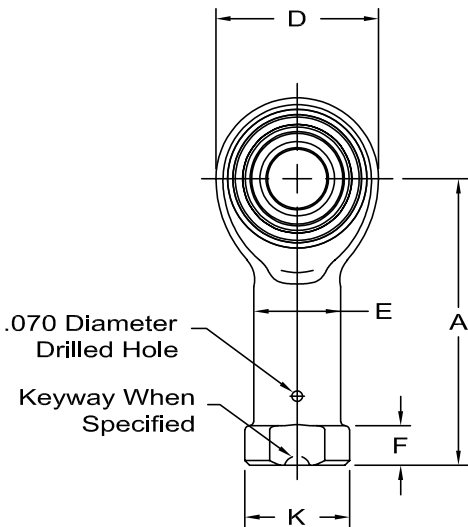

**Body** - 4340 alloy steel (AMS 6415), heat treated, cadmium plated

**Race** - 17-4 PH stainless steel (AMS 5643), heat treated

**Ball** - 440C stainless steel (AMS 5630), heat treated

**Liner** - AT3200 bearing liner, permanently bonded to race I.D., qualified to SAE-AS81820 Type A

SAE NO.		AURORA NO.		DIMENSIONS IN INCHES															
Right Hand	Left Hand	Right Hand	Left Hand	B +.0000 -.0005	W +.000 -.002	H ±.005	A ±.010	D ±.010	O Min.	S Max. Housing I.D.	E ±.010	K Ref. Dia.	J ±.010	F +.010 -.062	G ±.020	Ball Dia. Ref.	P Max.	C Min.	Thread UNJF-3B
M81935/5-03	M81935/5-03L	ATW-3T	ATG-3T	.1900	.281	.228	1.210	.680	.293	.5625	.329	.430	.375	.188	.312	.406	.750	.625	1/4-28
M81935/5-04	M81935/5-04L	ATW-4T	ATG-4T	.2500	.343	.260	1.338	.827	.364	.6562	.329	.430	.375	.188	.312	.500	.750	.625	1/4-28
M81935/5-05	M81935/5-05L	ATW-5T	ATG-5T	.3125	.375	.291	1.566	.984	.419	.7500	.413	.500	.437	.188	.375	.562	.875	.750	5/16-24
M81935/5-06	M81935/5-06L	ATW-6T	ATG-6T	.3750	.406	.322	1.908	1.131	.475	.8125	.501	.720	.625	.250	.437	.625	1.125	1.000	3/8-24
M81935/5-07	M81935/5-07L	ATW-7T	ATG-7T	.4375	.437	.353	2.125	1.294	.530	.9062	.584	.720	.625	.250	.500	.687	1.250	1.125	7/16-20
M81935/5-08	M81935/5-08L	ATW-8T	ATG-8T	.5000	.500	.400	2.356	1.459	.600	1.0000	.672	1.020	.875	.375	.562	.781	1.375	1.250	1/2-20
M81935/5-10	M81935/5-10L	ATW-10T	ATG-10T	.6250	.625	.510	2.707	1.763	.739	1.1875	.845	1.020	.875	.375	.687	.968	1.500	1.375	5/8-18
M81935/5-12	M81935/5-12L	ATW-12T	ATG-12T	.7500	.750	.603	3.193	2.140	.920	1.4375	1.017	1.300	1.125	.500	.812	1.187	1.750	1.625	3/4-16
M81935/5-14	M81935/5-14L	ATW-14T	ATG-14T	.8750	.875	.713	3.677	2.372	.980	1.5625	1.187	1.375	1.250	.500	.937	1.312	2.062	1.875	7/8-14
M81935/5-16	M81935/5-16L	ATW-16T	ATG-16T	1.0000	1.000	.807	4.101	2.681	1.118	1.7500	1.356	1.590	1.375	.500	1.062	1.500	2.312	2.125	1-12

### NOTES:

- Temperature Range: -65°F To +325°F (-54°C to +163°C)
- Keyslot, when specified, is compatible with locking devices: AS81935/3 for sizes -03 thru -08, and AS14277, NAS513, and NAS1193 for sizes -10 thru -16
- Keyslot designation "K" sizes -03 thru -08 (rounded slot) and sizes -10 thru -16 (square slot)
- Keyslot for sizes -03 thru -06 have 2 slots oriented perpendicular to the rod end hoop face (see diagram)
- Keyslot for sizes -07 thru -16 have 4 slots, 2 slots oriented perpendicular to the rod end hoop face (see diagram)
- AT 3200 Bearing Liner System is qualified for procurement under SAE-AS81820.
- Rod End Bearings listed are manufactured to conform to the dimensions, materials, and configurations of SAE-AS81935/5 and are approved for procurement under this specification
- Non-standard material, dimensional, or configuration specifications (not per the SAE Aerospace Standard Specification) can be provided. Consult factory for additional information
- The Rod End Bearings listed are available in non PTFE lined, metal on metal configuration (not per the SAE Aerospace Standard Specification), as well as with alternate Timken Aurora Bearing PTFE liner systems. Consult factory for additional information

Effective August 21st, 2023, the Naval Air Warfare Center Aircraft Division (NAWCAD) has disapproved Timken Aurora's qualification status for SAE-AS81820 and SAE-AS81935 specifications. Timken Aurora is working diligently to get requalified.

# ATW-T & ATG-T FEMALE ROD ENDS

SAE Series AS81935/5 (Right Hand) & AS81935/5 (Left Hand)



**Body** - 4340 alloy steel (AMS 6415), heat treated, cadmium plated

**Race** - 17-4 PH stainless steel (AMS 5643), heat treated

**Ball** - 440C stainless steel (AMS 5630), heat treated

**Liner** - AT3200 bearing liner, permanently bonded to race I.D., qualified to SAE-AS81820 Type A

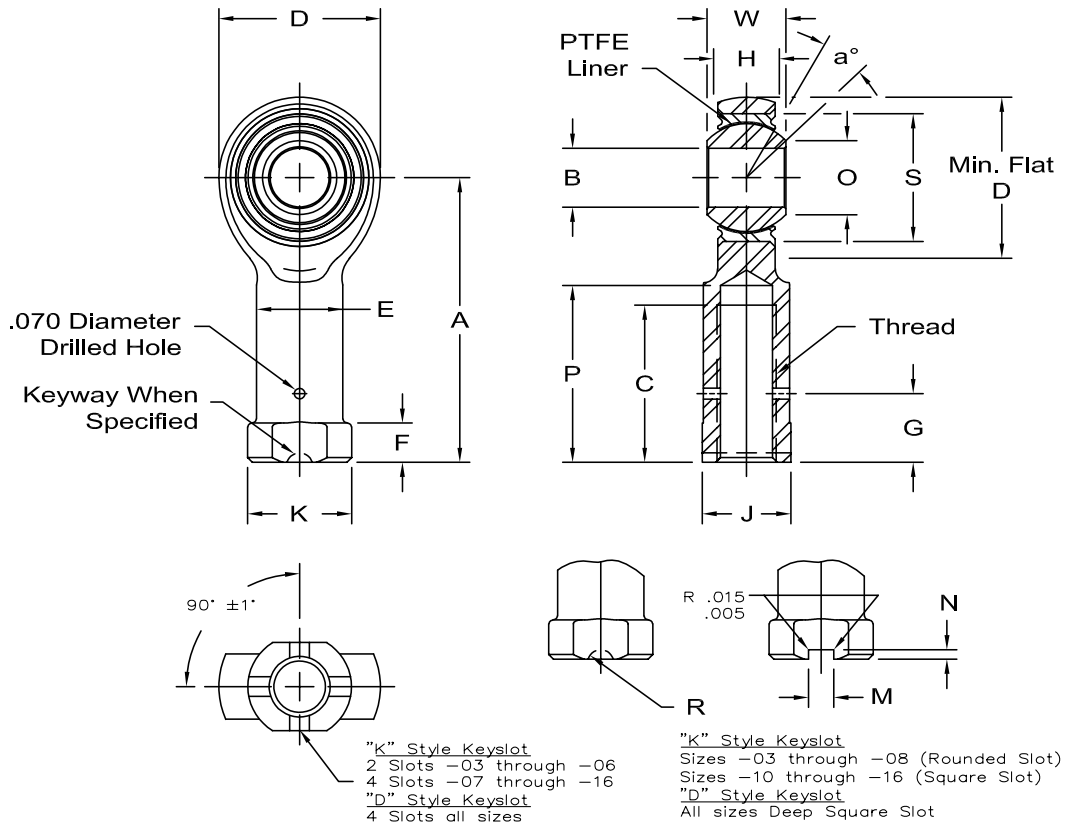

DIMENSIONS IN INCHES					a° Misalign. Angle Min.	Approx. Brg. Wt. Lbs.	Ult. Static Radial Load Lbs.	Fatigue Load Lbs.	Axial Proof Load Lbs.	No Load Rotational Breakaway Torque In-Lbs.		SAE NO.		AURORA NO.	
"K" STYLE KEYSLOT		"D" STYLE KEYSLOT								Min.	Max.	Right Hand	Left Hand	Right Hand	Left Hand
M	N	R + .010 - .000	M + .005 - .000	N + .005 - .000											
-	.055 - .065	.078	.062	.110	10	.045	3,000	1,100	150	.5	6	M81935/5-03	M81935/5-03L	ATW-3T	ATG-3T
-	.055 - .065	.078	.062	.110	10	.060	5,500	1,300	430	.5	6	M81935/5-04	M81935/5-04L	ATW-4T	ATG-4T
-	.055 - .065	.078	.062	.110	10	.100	8,900	2,000	700	1	15	M81935/5-05	M81935/5-05L	ATW-5T	ATG-5T
-	.055 - .065	.078	.093	.110	9	.145	13,400	3,100	1,100	1	15	M81935/5-06	M81935/5-06L	ATW-6T	ATG-6T
-	.055 - .065	.078	.093	.110	8	.215	18,200	4,200	1,400	1	15	M81935/5-07	M81935/5-07L	ATW-7T	ATG-7T
-	.055 - .065	.078	.093	.110	8	.305	24,600	5,700	2,040	1	15	M81935/5-08	M81935/5-08L	ATW-8T	ATG-8T
.125 - .130	.077 - .082	-	.125	.110	8	.550	39,500	9,200	2,430	1	15	M81935/5-10	M81935/5-10L	ATW-10T	ATG-10T
.125 - .130	.077 - .082	-	.125	.110	8	.930	57,200	13,500	2,940	1	15	M81935/5-12	M81935/5-12L	ATW-12T	ATG-12T
.156 - .161	.086 - .091	-	.156	.110	8	1.390	77,800	18,400	3,100	1	24	M81935/5-14	M81935/5-14L	ATW-14T	ATG-14T
.156 - .161	.094 - .099	-	.156	.110	9	1.975	101,000	24,000	3,570	1	24	M81935/5-16	M81935/5-16L	ATW-16T	ATG-16T

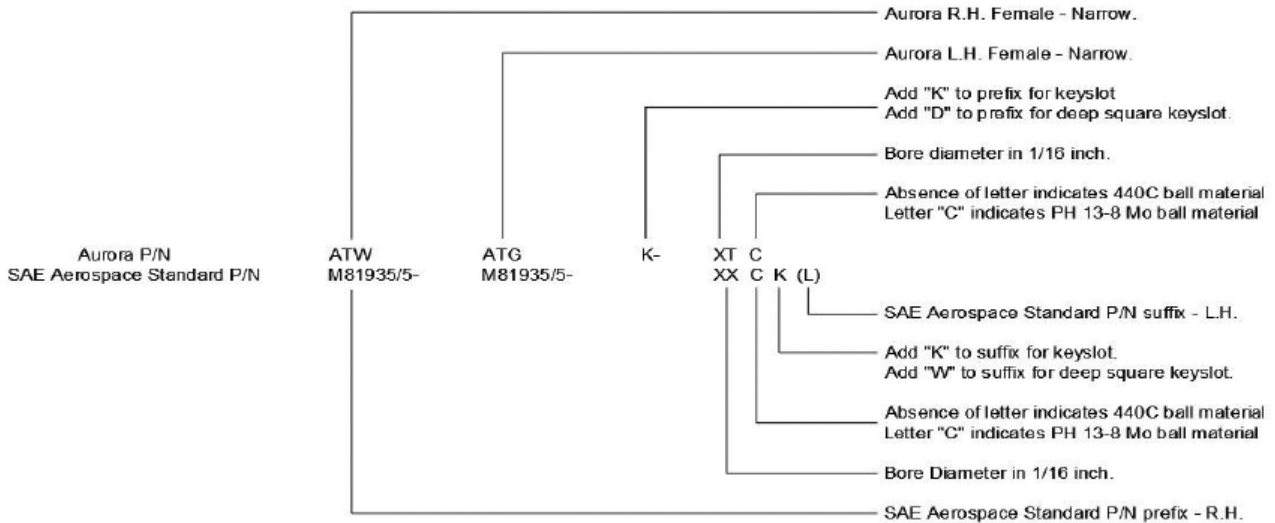

Effective August 21st, 2023, the Naval Air Warfare Center Aircraft Division (NAWCAD) has disapproved Timken Aurora's qualification status for SAE-AS81820 and SAE-AS81935 specifications. Timken Aurora is working diligently to get requalified.

timkenaurorabearing.com • Fax 630-859-0971



# ASM-ET & ASB-ET MALE ROD ENDS

SAE Series AS81935/6 (Right Hand) & AS81935/6 (Left Hand)

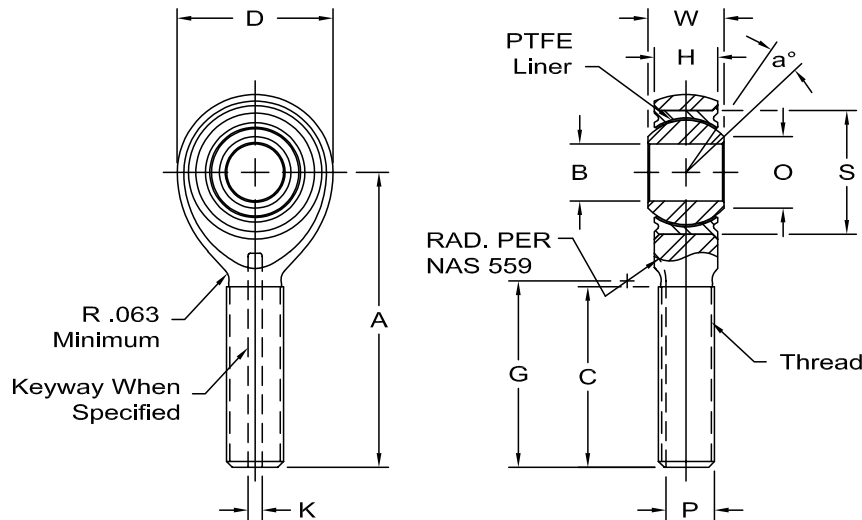

**Body** - PH 13-8 Mo Stainless Steel (AMS 5629), heat treated.

**Race** - 17-4 PH Stainless Steel (AMS 5643), heat treated.

**Ball** - 440C stainless steel (AMS 5630), heat treated

**Liner** - AT 3200 bearing liner, permanently bonded to race I.D., qualified to SAE-AS81820 Type A

timkenaurorabearing.com • Fax 630-859-0971

SAE NO.		AURORA NO.		DIMENSIONS IN INCHES										
Right Hand	Left Hand	Right Hand	Left Hand	B +.0000 -.0005	W +.000 -.002	H ± .005	A ± .010	D ± .010	O Min.	S Max. Housing I.D.	Ball Dia. Ref.	G +.000 -.020	K +.005 -.000	P +.000 -.005
M81935/6-03	M81935/6-03L	ASM-3ET	ASB-3ET	.1900	.437	.337	1.562	.806	.30	.6250	.531	.980	.062	.268
M81935/6-04	M81935/6-04L	ASM-4ET	ASB-4ET	.2500	.437	.337	1.562	.806	.30	.6250	.531	.980	.062	.268
M81935/6-05	M81935/6-05L	ASM-5ET	ASB-5ET	.3125	.437	.327	1.875	.900	.36	.6875	.593	1.270	.062	.268
M81935/6-06	M81935/6-06L	ASM-6ET	ASB-6ET	.3750	.500	.416	1.938	1.025	.47	.8125	.687	1.235	.093	.319
M81935/6-07	M81935/6-07L	ASM-7ET	ASB-7ET	.4375	.562	.452	2.125	1.150	.54	.9062	.781	1.402	.093	.383
M81935/6-08	M81935/6-08L	ASM-8ET	ASB-8ET	.5000	.625	.515	2.438	1.337	.61	1.0000	.875	1.589	.093	.445
M81935/6-10	M81935/6-10L	ASM-10ET	ASB-10ET	.6250	.750	.577	2.625	1.525	.75	1.1875	1.062	1.683	.125	.541
M81935/6-12	M81935/6-12L	ASM-12ET	ASB-12ET	.7500	.875	.640	2.875	1.775	.85	1.3750	1.250	1.808	.125	.663
M81935/6-14	M81935/6-14L	ASM-14ET	ASB-14ET	.8750	.875	.765	3.375	2.025	1.00	1.6250	1.375	2.121	.156	.777
M81935/6-16	M81935/6-16L	ASM-16ET	ASB-16ET	1.0000	1.375	1.015	4.125	2.775	1.27	2.1250	1.875	2.464	.187	1.136

### NOTES:

- Temperature Range: -65°F To +325°F (-54°C to +163°C)
- Keyway, when specified, is compatible with locking devices: AS81935/3 for sizes - 03 thru -08, and NAS 513 for sizes -10 thru -16
- AT 3200 Bearing Liner System is qualified for procurement under SAE-AS81820 Type A
- Rod End Bearings listed are manufactured to conform to the dimensions, materials, and configurations of SAE-AS81935/6 and are approved for procurement under this specification
- Non-standard material, dimensional, or configurations (not per the SAE Aerospace Standard Specification) can be provided. Consult factory for additional information
- The Rod End Bearings listed are available in non PTFE lined, metal on metal configuration (not per the SAE Aerospace Standard Specification), as well as with alternate Timken Aurora Bearing PTFE liner systems. Consult factory for additional information

Effective August 21st, 2023, the Naval Air Warfare Center Aircraft Division (NAWCAD) has disapproved Timken Aurora's qualification status for SAE-AS81820 and SAE-AS81935 specifications. Timken Aurora is working diligently to get requalified.

# ASM-ET & ASB-ET MALE ROD ENDS

SAE Series AS81935/6 (Right Hand) & AS81935/6 (Left Hand)

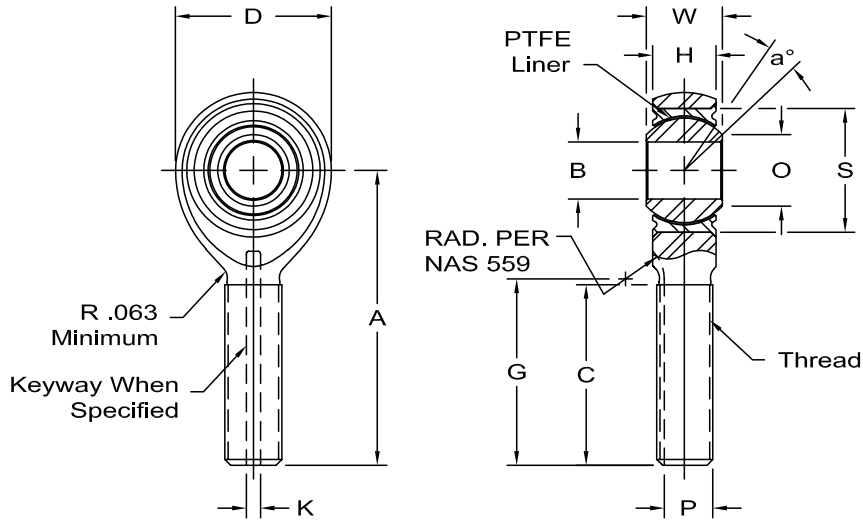

**Body** - PH 13-8 Mo Stainless Steel (AMS 5629), heat treated.

**Race** - 17-4 PH Stainless Steel (AMS 5643), heat treated.

**Ball** - 440C stainless steel (AMS 5630), heat treated

**Liner** - AT 3200 bearing liner, permanently bonded to race I.D., qualified to SAE-AS81820 Type A

C ± .031	Thread UNJF-3A	a° Misalign. Angle Min.	Approx. Brg. Wt. Lbs.	Ult. Static Radial Load Lbs.	Fatigue Load Lbs.	Axial Proof Load Lbs.	No Load Rotational Breakaway Torque In-Lbs.		SAE NO.		AURORA NO.	
							Min.	Max.	Right Hand	Left Hand	Right Hand	Left Hand
.968	5/16-24	15	.072	2,360	1,470*	1,000	.5	6	M81935/6-03	M81935/6-03L	ASM-3ET	ASB-3ET
.968	5/16-24	15	.072	4,860	2,380	1,000	.5	6	M81935/6-04	M81935/6-04L	ASM-4ET	ASB-4ET
1.187	5/16-24	14	.087	7,180	2,770**	1,100	1	15	M81935/6-05	M81935/6-05L	ASM-5ET	ASB-5ET
1.187	3/8-24	8	.136	8,550	3,570	1,660	1	15	M81935/6-06	M81935/6-06L	ASM-6ET	ASB-6ET
1.281	7/16-20	10	.183	12,000	4,800	1,850	1	15	M81935/6-07	M81935/6-07L	ASM-7ET	ASB-7ET
1.468	1/2-20	9	.278	19,500	7,680**	2,040	1	15	M81935/6-08	M81935/6-08L	ASM-8ET	ASB-8ET
1.562	5/8-18	12	.424	21,900	9,180	2,430	1	15	M81935/6-10	M81935/6-10L	ASM-10ET	ASB-10ET
1.687	3/4-16	13	.639	29,300	11,600	2,810	1	15	M81935/6-12	M81935/6-12L	ASM-12ET	ASB-12ET
2.000	7/8-14	6	.963	34,500	13,100	3,320	1	24	M81935/6-14	M81935/6-14L	ASM-14ET	ASB-14ET
2.343	1 1/4-12	12	2.546	80,300	30,400	4,340	1	24	M81935/6-16	M81935/6-16L	ASM-16ET	ASB-16ET

\* Based on bolt bending fatigue strength 180,000 PSI

\*\* Shank limitation

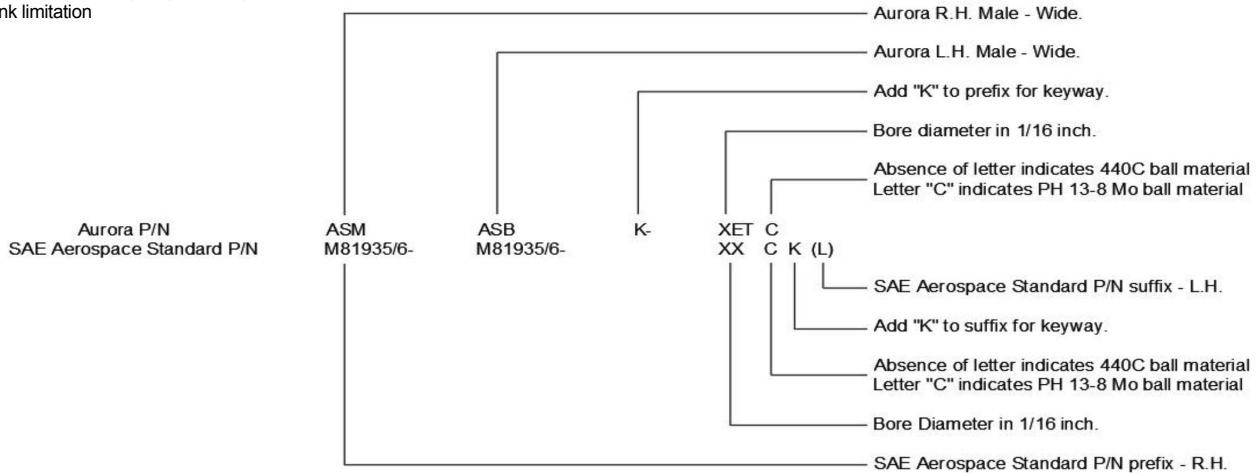

Effective August 21st, 2023, the Naval Air Warfare Center Aircraft Division (NAWCAD) has disapproved Timken Aurora's qualification status for SAE-AS81820 and SAE-AS81935 specifications. Timken Aurora is working diligently to get requalified.

timkenaurorabearing.com • Fax 630-859-0971



# ASW-ET & ASG-ET FEMALE ROD ENDS

SAE Series AS81935/7 (Right Hand) & AS81935/7 (Left Hand)

timkenaurorabearing.com • Fax 630-859-0971

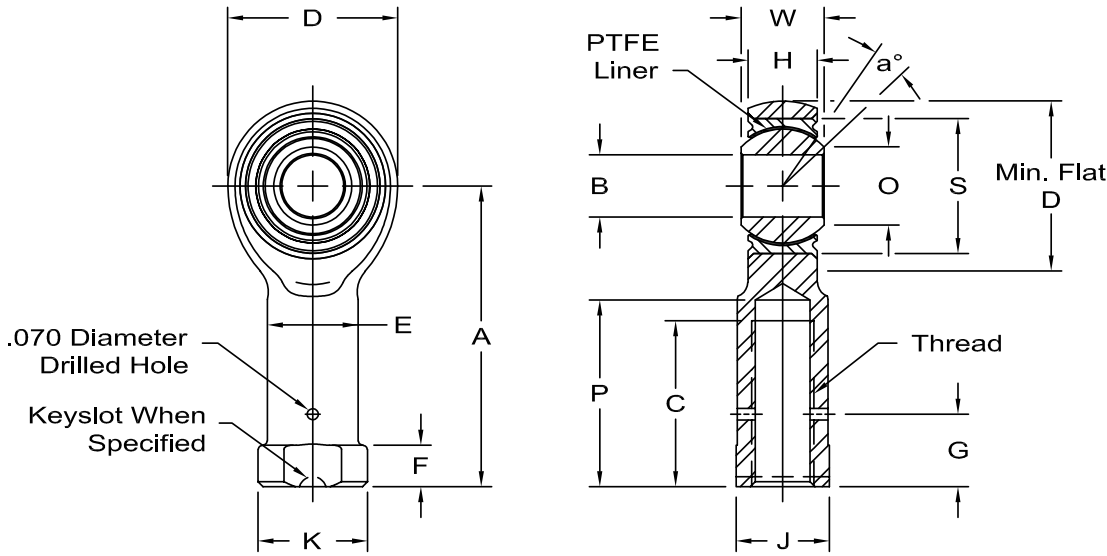

**Body** - PH 13-8 Mo stainless steel (AMS 5629), heat treated

**Race** - 17-4 PH stainless steel (AMS 5643), heat treated

**Ball** - 440C stainless steel (AMS 5630), heat treated

**Liner** - AT 3200 bearing liner, permanently bonded to race I.D., qualified to SAE-AS81820 Type A

SAE NO.		AURORA NO.		DIMENSIONS IN INCHES															
Right Hand	Left Hand	Right Hand	Left Hand	B +.0000 -.0005	W +.000 -.002	H ±.005	A ±.010	D ±.010	O Min.	S Max. Housing I.D.	E ±.010	K Ref. Dia.	J ±.010	F +.010 -.062	G ±.020	Ball Dia. Ref.	P Max.	C Min.	Thread UNJF-3B
M81935/7-03	M81935/7-03L	ASW-3ET	ASG-3ET	.1900	.437	.337	1.375	.806	.30	.6250	.422	.500	.437	.188	.375	.531	.875	.750	5/16-24
M81935/7-04	M81935/7-04L	ASW-4ET	ASG-4ET	.2500	.437	.337	1.469	.806	.30	.6250	.422	.500	.437	.188	.375	.531	.875	.750	5/16-24
M81935/7-05	M81935/7-05L	ASW-5ET	ASG-5ET	.3125	.437	.327	1.625	.900	.36	.6875	.485	.580	.500	.250	.437	.593	1.000	.875	3/8-24
M81935/7-06	M81935/7-06L	ASW-6ET	ASG-6ET	.3750	.500	.416	1.812	1.025	.47	.8125	.547	.660	.562	.250	.437	.687	1.125	1.000	3/8-24
M81935/7-07	M81935/7-07L	ASW-7ET	ASG-7ET	.4375	.562	.452	2.000	1.150	.54	.9062	.610	.720	.625	.250	.500	.781	1.250	1.125	7/16-20
M81935/7-08	M81935/7-08L	ASW-8ET	ASG-8ET	.5000	.625	.515	2.250	1.337	.61	1.0000	.735	.880	.750	.250	.562	.875	1.375	1.250	1/2-20
M81935/7-10	M81935/7-10L	ASW-10ET	ASG-10ET	.6250	.750	.577	2.500	1.525	.75	1.1875	.860	1.020	.875	.375	.687	1.062	1.500	1.375	5/8-18
M81935/7-12	M81935/7-12L	ASW-12ET	ASG-12ET	.7500	.875	.640	2.875	1.775	.85	1.3750	.985	1.160	1.000	.375	.812	1.250	1.750	1.625	3/4-16
M81935/7-14	M81935/7-14L	ASW-14ET	ASG-14ET	.8750	.875	.765	3.375	2.025	1.00	1.6250	1.110	1.300	1.125	.500	.937	1.375	2.062	1.875	7/8-14
M81935/7-16	M81935/7-16L	ASW-16ET	ASG-16ET	1.0000	1.375	1.015	4.125	2.775	1.27	2.1250	1.688	2.020	1.750	.563	1.312	1.875	2.312	2.125	1 1/4-12

### NOTES:

- Temperature Range: -65°F To +325°F (-54°C to +163°C)
- Keyslot, when specified, is compatible with locking devices: AS81935/3 for sizes -03 thru -08, and AS14277, NAS513, and NAS1193 for sizes -10 thru -16
- Keyslot designation "K" sizes -03 thru -08 (rounded slot) and sizes -10 thru -16 (square slot)
- Keyslot for sizes -03 thru -06 have 2 slots oriented perpendicular to the rod end hoop face (see diagram)
- Keyslot for sizes -07 thru -16 have 4 slots, 2 slots oriented perpendicular to the rod end hoop face (see diagram)
- AT 3200 Bearing Liner System is qualified for procurement under SAE-AS81820.
- Rod End Bearings listed are manufactured to conform to the dimensions, materials, and configurations of SAE-AS81935/7 and are approved for procurement under this specification
- Non-standard material, dimensional, or configuration specifications (not per the SAE Aerospace Standard Specification) can be provided. Consult factory for additional information
- The Rod End Bearings listed are available in non PTFE lined, metal on metal configuration (not per the SAE Aerospace Standard Specification), as well as with alternate Timken Aurora Bearing PTFE liner systems. Consult factory for additional information

Effective August 21st, 2023, the Naval Air Warfare Center Aircraft Division (NAWCAD) has disapproved Timken Aurora's qualification status for SAE-AS81820 and SAE-AS81935 specifications. Timken Aurora is working diligently to get requalified.

# ASW-ET & ASG-ET FEMALE ROD ENDS

SAE Series AS81935/7 (Right Hand) & AS81935/7 (Left Hand)

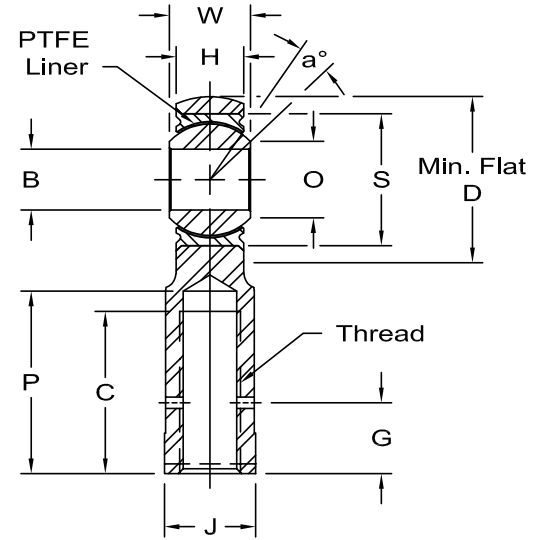
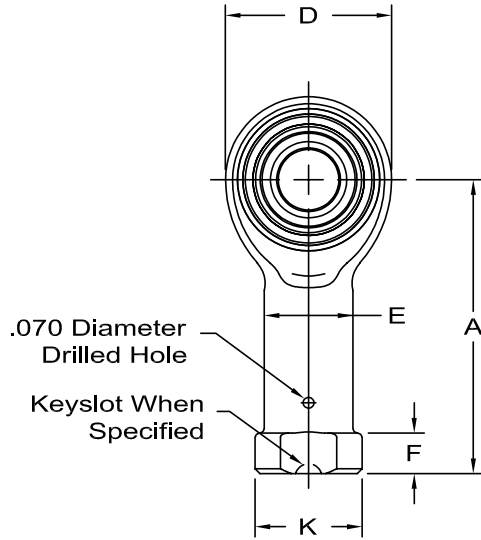

**Body** - PH 13-8 Mo stainless steel (AMS 5629), heat treated

**Race** - 17-4 PH stainless steel (AMS 5643), heat treated

**Ball** - 440C stainless steel (AMS 5630), heat treated

**Liner** - AT 3200 bearing liner, permanently bonded to race I.D., qualified to SAE-AS81820 Type A

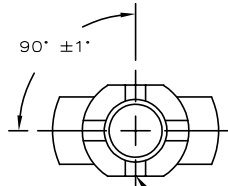

"K" Style Keyslot  
2 Slots -03 through -06  
4 Slots -07 through -16  
"D" Style Keyslot  
4 Slots all sizes

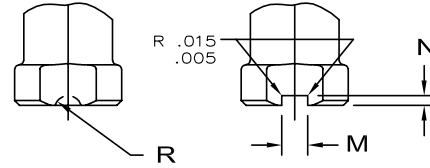

"K" Style Keyslot  
Sizes -03 through -08 (Rounded Slot)  
Sizes -10 through -16 (Square Slot)  
"D" Style Keyslot  
All sizes Deep Square Slot

DIMENSIONS IN INCHES					a° Misalign. Angle Ref.	Approx. Brg. Wt. Lbs.	Ult. Static Radial Load Lbs.	Fatigue Load Lbs.	Axial Proof Load Lbs.	No Load Rotational Breakaway Torque In-Lbs.		SAE NO.		AURORA NO.	
"K" STYLE KEYSLOT		"D" STYLE KEYSLOT								Min.	Max.	Right Hand	Left Hand	Right Hand	Left Hand
M	N	R + .010 - .000	M + .005 - .000	N + .005 - .000											
-	.055-.065	.078	.062	.110	15	.080	2,360	1,470*	1,000	.5	6	M81935/7-03	M81935/7-03L	ASW-3ET	ASG-3ET
-	.055-.065	.078	.062	.110	15	.084	4,860	2,380	1,000	.5	6	M81935/7-04	M81935/7-04L	ASW-4ET	ASG-4ET
-	.055-.065	.078	.093	.110	14	.102	7,180	3,020	1,100	1	15	M81935/7-05	M81935/7-05L	ASW-5ET	ASG-5ET
-	.055-.065	.078	.093	.110	8	.161	8,550	3,570	1,660	1	15	M81935/7-06	M81935/7-06L	ASW-6ET	ASG-6ET
-	.055-.065	.078	.093	.110	10	.212	12,000	4,800	1,850	1	15	M81935/7-07	M81935/7-07L	ASW-7ET	ASG-7ET
-	.055-.065	.078	.093	.110	9	.325	19,500	8,260	2,040	1	15	M81935/7-08	M81935/7-08L	ASW-8ET	ASG-8ET
.125-.130	.077-.082	-	.125	.110	12	.481	21,900	9,180	2,430	1	15	M81935/7-10	M81935/7-10L	ASW-10ET	ASG-10ET
.125-.130	.077-.082	-	.125	.110	13	.673	29,300	11,600	2,810	1	15	M81935/7-12	M81935/7-12L	ASW-12ET	ASG-12ET
.156-.161	.086-.091	-	.156	.110	6	.959	34,500	13,100	3,320	1	24	M81935/7-14	M81935/7-14L	ASW-14ET	ASG-14ET
.187-.192	.116-.121	-	.187	.116	12	2,717	80,300	30,400	4,340	1	24	M81935/7-16	M81935/7-16L	ASW-16ET	ASG-16ET

\* Based on bolt bending fatigue strength 180,000 PSI

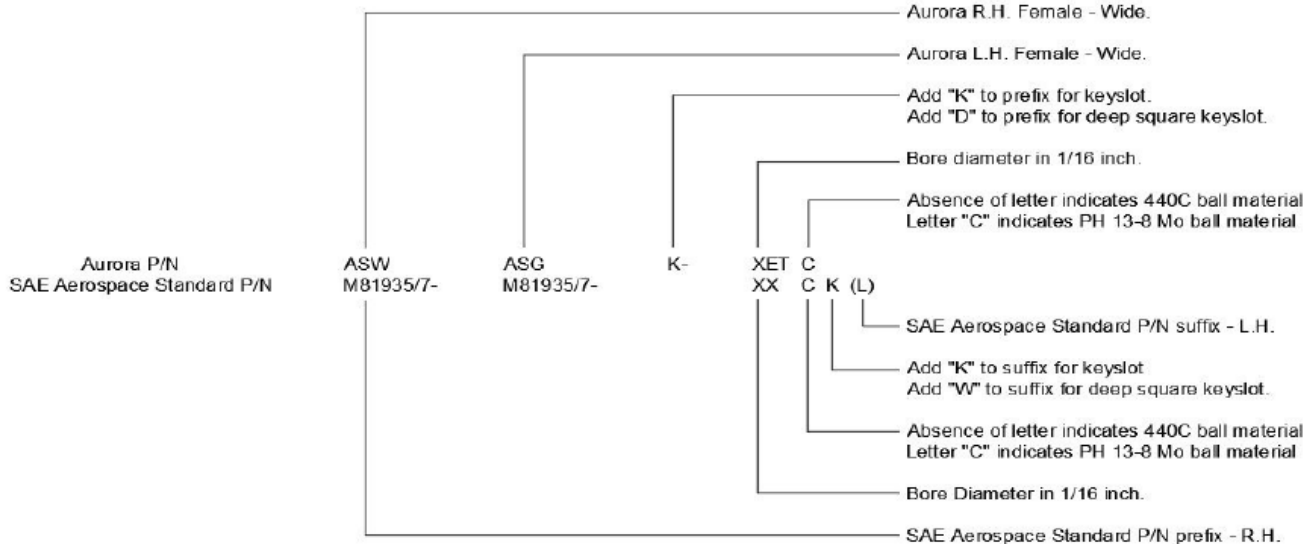

Effective August 21st, 2023, the Naval Air Warfare Center Aircraft Division (NAWCAD) has disapproved Timken Aurora's qualification status for SAE-AS81820 and SAE-AS81935 specifications. Timken Aurora is working diligently to get requalified.

timkenaurorabearing.com • Fax 630-859-0971



# ATM-ET & ATB-ET MALE ROD ENDS

SAE Series AS81935/8 (Right Hand) & AS81935/8 (Left Hand)

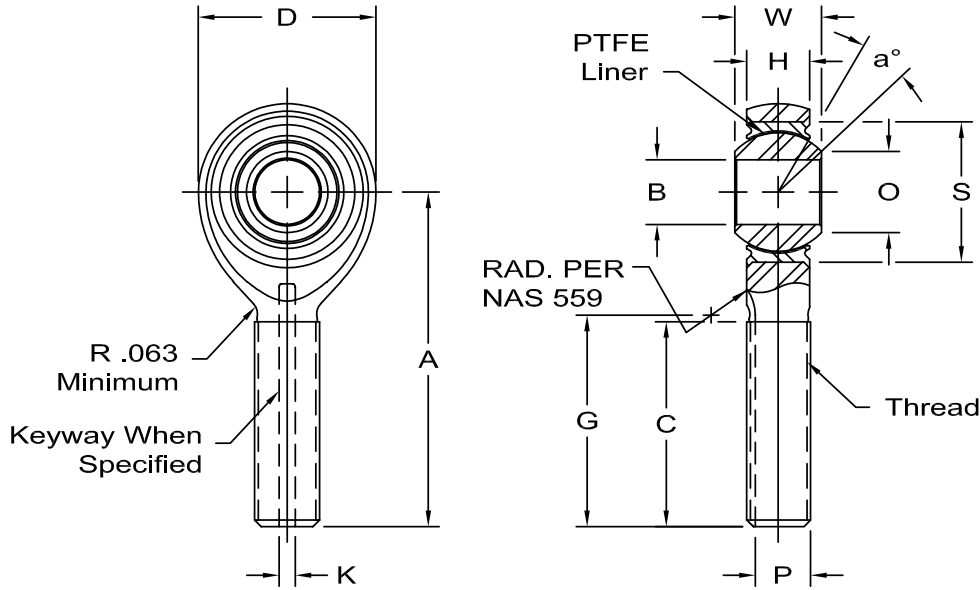

**Body** - PH 13-8 Mo stainless steel (AMS 5629), heat treated.

**Race** - 17-4 Ph stainless steel. (AMS 5643), heat treated.

**Ball** - 440C stainless steel (AMS 5630), heat treated

**Liner** - AT 3200 bearing liner, permanently bonded to race I.D., qualified to SAE-AS81820 Type A

timkenaurorabearing.com • Fax 630-859-0971

SAE NO.		AURORA NO.		DIMENSIONS IN INCHES										
Right Hand	Left Hand	Right Hand	Left Hand	B +.0000 -.0005	W +.000 -.002	H ± .005	A ± .010	D ± .010	O Min.	S Max. Housing I.D.	Ball Dia. Ref.	G ‡ +.000 -.020	K +.005 -.000	P +.000 -.005
M81935/8-03	M81935/8-03L	ATM-3ET	ATB-3ET	.1900	.281	.228	1.315	.680	.293	.5625	.406	.896	.062	.207
M81935/8-04	M81935/8-04L	ATM-4ET	ATB-4ET	.2500	.343	.260	1.443	.827	.364	.6562	.500	.896	.062	.207
M81935/8-05	M81935/8-05L	ATM-5ET	ATB-5ET	.3125	.375	.291	1.948	.984	.419	.7500	.562	1.308	.062	.268
M81935/8-06	M81935/8-06L	ATM-6ET	ATB-6ET	.3750	.406	.322	2.030	1.131	.475	.8125	.625	1.308	.093	.319
M81935/8-07	M81935/8-07L	ATM-7ET	ATB-7ET	.4375	.437	.353	2.250	1.294	.530	.9062	.687	1.402	.093	.383
M81935/8-08	M81935/8-08L	ATM-8ET	ATB-8ET	.5000	.500	.400	2.544	1.459	.600	1.0000	.781	1.589	.093	.445
M81935/8-10	M81935/8-10L	ATM-10ET	ATB-10ET	.6250	.625	.510	2.832	1.763	.739	1.1875	.968	1.683	.125	.541
M81935/8-12	M81935/8-12L	ATM-12ET	ATB-12ET	.7500	.750	.603	3.193	2.140	.920	1.4375	1.187	1.808	.125	.663
M81935/8-14	M81935/8-14L	ATM-14ET	ATB-14ET	.8750	.875	.713	3.677	2.372	.980	1.5625	1.312	2.121	.156	.777
M81935/8-16	M81935/8-16L	ATM-16ET	ATB-16ET	1.0000	1.000	.807	3.968	2.681	1.118	1.7500	1.500	2.221	.156	.900

‡ -03 "G" + .000, -.060

### NOTES:

- Temperature Range: -65°F To +325°F (-54°C to +163°C)
- Keyway, when specified, is compatible with locking devices: AS81935/3 for sizes -03 thru -08, and NAS 513 for sizes -10 thru -16
- AT 3200 Bearing Liner System is qualified for procurement under SAE-AS81820 Type A
- Rod End Bearings listed are manufactured to conform to the dimensions, materials, and configurations of SAE-AS81935/8 and are approved for procurement under this specification
- Non-standard material, dimensional, or configurations (not per the SAE Aerospace Standard Specification) can be provided. Consult factory for additional information
- The Rod End Bearings listed are available in non PTFE lined, metal on metal configuration (not per the SAE Aerospace Standard Specification), as well as with alternate Timken Aurora Bearing PTFE liner systems. Consult factory for additional information

Effective August 21st, 2023, the Naval Air Warfare Center Aircraft Division (NAWCAD) has disapproved Timken Aurora's qualification status for SAE-AS81820 and SAE-AS81935 specifications. Timken Aurora is working diligently to get requalified.



# ATM-ET & ATB-ET MALE ROD ENDS

SAE Series AS81935/8 (Right Hand) & AS81935/8 (Left Hand)

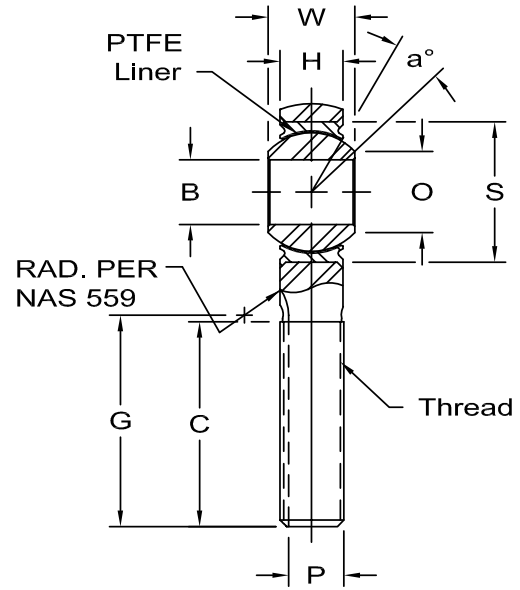
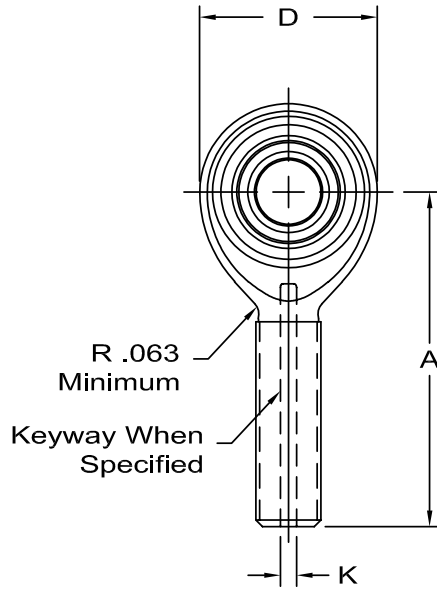

**Body** - PH 13-8 Mo stainless steel (AMS 5629), heat treated.

**Race** - 17-4 Ph stainless steel. (AMS 5643), heat treated.

**Ball** - 440C stainless steel (AMS 5630), heat treated

**Liner** - AT 3200 bearing liner, permanently bonded to race I.D., qualified to SAE-AS81820 Type A

timkenaurorabearing.com • Fax 630-859-0971

C ± .031	Thread UNJF-3A	a° Misalign. Angle Min.	Approx. Brg. Wt. Lbs.	Ult. Static Radial Load Lbs.	Fatigue Load Lbs.	Axial Proof Load Lbs.	No Load Rotational Breakaway Torque In-Lbs.		SAE NO.		AURORA NO.	
							Min.	Max.	Right Hand	Left Hand	Right Hand	Left Hand
.775	1/4-28	10	.045	3,000	1,100	150	.5	6	M81935/8-03	M81935/8-03L	ATM-3ET	ATB-3ET
.775	1/4-28	10	.060	5,300	1,500	430	.5	6	M81935/8-04	M81935/8-04L	ATM-4ET	ATB-4ET
1.187	5/16-24	10	.100	8,600	2,400	700	1	15	M81935/8-05	M81935/8-05L	ATM-5ET	ATB-5ET
1.187	3/8-24	9	.135	13,000	3,600	1,100	1	15	M81935/8-06	M81935/8-06L	ATM-6ET	ATB-6ET
1.281	7/16-20	8	.200	17,800	5,000	1,400	1	15	M81935/8-07	M81935/8-07L	ATM-7ET	ATB-7ET
1.468	1/2-20	8	.285	24,200	6,800	2,040	1	15	M81935/8-08	M81935/8-08L	ATM-8ET	ATB-8ET
1.562	5/8-18	8	.505	38,500	10,800	2,430	1	15	M81935/8-10	M81935/8-10L	ATM-10ET	ATB-10ET
1.687	3/4-16	8	.830	56,600	16,000	2,940	1	15	M81935/8-12	M81935/8-12L	ATM-12ET	ATB-12ET
2.000	7/8-14	8	1.235	77,400	21,900	3,190	1	24	M81935/8-14	M81935/8-14L	ATM-14ET	ATB-14ET
2.100	1-12	9	1.725	101,400	28,600	3,570	1	24	M81935/8-16	M81935/8-16L	ATM-16ET	ATB-16ET

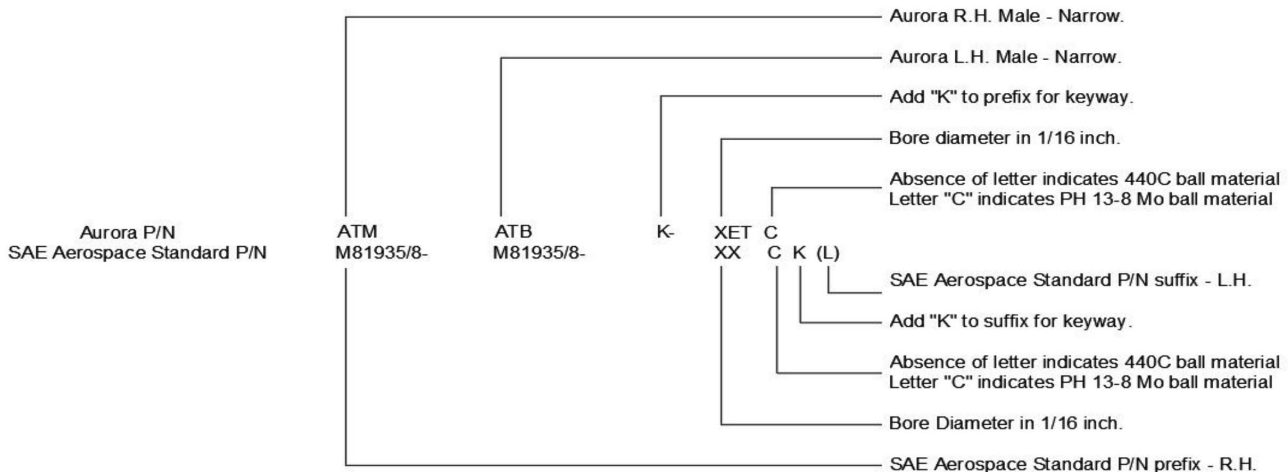

Effective August 21st, 2023, the Naval Air Warfare Center Aircraft Division (NAWCAD) has disapproved Timken Aurora's qualification status for SAE-AS81820 and SAE-AS81935 specifications. Timken Aurora is working diligently to get requalified.



# ATW-ET & ATG-ET FEMALE ROD ENDS

SAE Series AS81935/9 (Right Hand) & AS81935/9 (Left Hand)

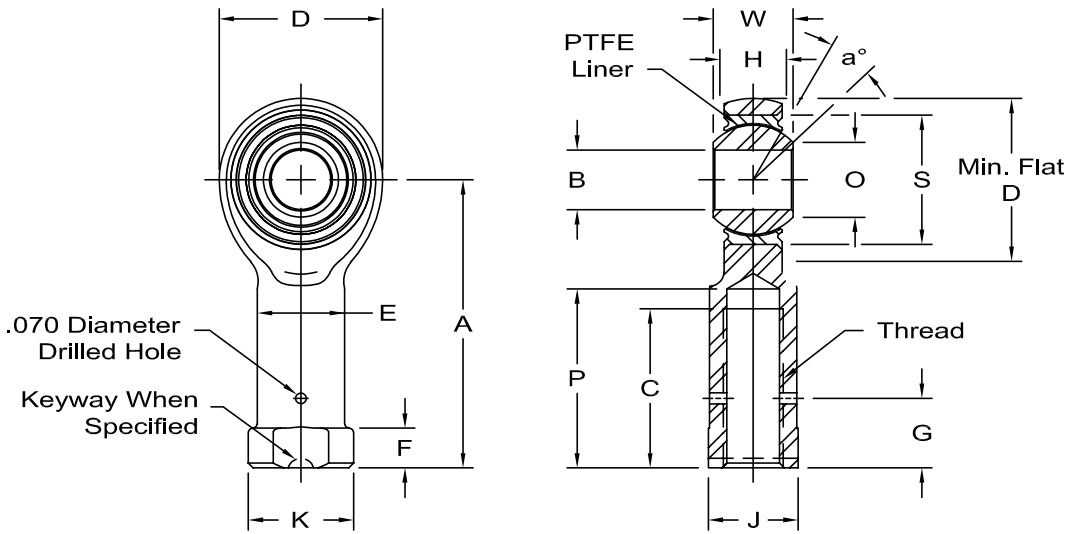

**Body** - PH 13-8 Mo stainless steel (AMS 5629), heat treated.

**Race** - 17-4 PH stainless steel (AMS 5643), heat treated

**Ball** - 440C stainless steel (AMS 5630), heat treated

**Liner** - AT 3200 bearing liner, permanently bonded to race I.D., qualified to SAE-AS81820 Type A

timkenaurorabearing.com • Fax 630-859-0971

SAE NO.		AURORA NO.		DIMENSIONS IN INCHES															
Right Hand	Left Hand	Right Hand	Left Hand	B +.0000 -.0005	W +.000 -.002	H ±.005	A ±.010	D ±.010	O Min.	S Max. Housing I.D.	E ±.010	K Ref. Dia.	J ±.010	F +.010 -.062	G ±.020	Ball Dia. Ref.	P Max.	C Min.	Thread UNJF-3B
M81935/9-03	M81935/9-03L	ATW-3ET	ATG-3ET	.1900	.281	.228	1.210	.680	.293	.5625	.329	.430	.375	.188	.312	.406	.750	.625	1/4-28
M81935/9-04	M81935/9-04L	ATW-4ET	ATG-4ET	.2500	.343	.260	1.338	.827	.364	.6562	.329	.430	.375	.188	.312	.500	.750	.625	1/4-28
M81935/9-05	M81935/9-05L	ATW-5ET	ATG-5ET	.3125	.375	.291	1.566	.984	.419	.7500	.413	.500	.437	.188	.375	.562	.875	.750	5/16-24
M81935/9-06	M81935/9-06L	ATW-6ET	ATG-6ET	.3750	.406	.322	1.908	1.131	.475	.8125	.501	.720	.625	.250	.437	.625	1.125	1.000	3/8-24
M81935/9-07	M81935/9-07L	ATW-7ET	ATG-7ET	.4375	.437	.353	2.125	1.294	.530	.9062	.584	.720	.625	.250	.500	.687	1.250	1.125	7/16-20
M81935/9-08	M81935/9-08L	ATW-8ET	ATG-8ET	.5000	.500	.400	2.356	1.459	.600	1.0000	.672	1.020	.875	.375	.562	.781	1.375	1.250	1/2-20
M81935/9-10	M81935/9-10L	ATW-10ET	ATG-10ET	.6250	.625	.510	2.707	1.763	.739	1.1875	.845	1.020	.875	.375	.687	.968	1.500	1.375	5/8-18
M81935/9-12	M81935/9-12L	ATW-12ET	ATG-12ET	.7500	.750	.603	3.193	2.140	.920	1.4375	1.017	1.300	1.125	.500	.812	1.187	1.750	1.625	3/4-16
M81935/9-14	M81935/9-14L	ATW-14ET	ATG-14ET	.8750	.875	.713	3.677	2.372	.980	1.5625	1.187	1.375	1.250	.500	.937	1.312	2.062	1.875	7/8-14
M81935/9-16	M81935/9-16L	ATW-16ET	ATG-16ET	1.0000	1.000	.807	4.101	2.681	1.118	1.7500	1.356	1.590	1.375	.500	1.062	1.500	2.312	2.125	1-12

### NOTES:

- Temperature Range: -65°F To +325°F (-54°C to +163°C)
- Keyslot, when specified, is compatible with locking devices: AS81935/3 for sizes -03 thru -08, and AS14277, NAS513, and NAS1193 for sizes -10 thru -16
- Keyslot designation "K" sizes -03 thru -08 (rounded slot) and sizes -10 thru -16 (square slot)
- Keyslot for sizes -03 thru -06 have 2 slots oriented perpendicular to the rod end hoop face (see diagram)
- Keyslot for sizes -07 thru -16 have 4 slots, 2 slots oriented perpendicular to the rod end hoop face (see diagram)
- AT 3200 Bearing Liner System is qualified for procurement under SAE-AS81820.
- Rod End Bearings listed are manufactured to conform to the dimensions, materials, and configurations of SAE-AS81935/9 and are approved for procurement under this specification
- Non-standard material, dimensional, or configuration specifications (not per the SAE Aerospace Standard Specification) can be provided. Consult factory for additional information
- The Rod End Bearings listed are available in non PTFE lined, metal on metal configuration (not per the SAE Aerospace Standard Specification), as well as with alternate Timken Aurora Bearing PTFE liner systems. Consult factory for additional information

Effective August 21st, 2023, the Naval Air Warfare Center Aircraft Division (NAWCAD) has disapproved Timken Aurora's qualification status for SAE-AS81820 and SAE-AS81935 specifications. Timken Aurora is working diligently to get requalified.

# ATW-ET & ATG-ET FEMALE ROD ENDS

SAE Series AS81935/9 (Right Hand) & AS81935/9 (Left Hand)

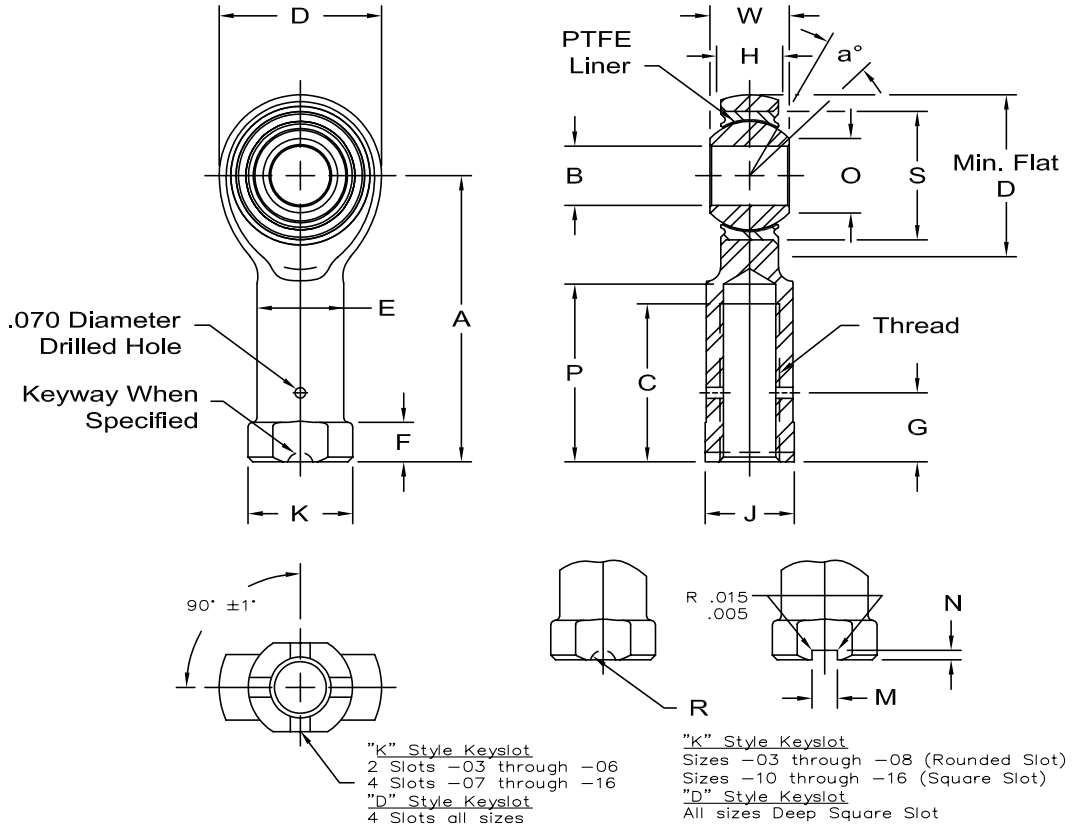

DIMENSIONS IN INCHES					a° Misalign. Angle Ref.	Approx. Brg. Wt. Lbs.	Ult. Static Radial Load Lbs.	Fatigue Load Lbs.	Axial Proof Load Lbs.	No Load Rotational Breakaway Torque In-Lbs.	SAE NO.		AURORA NO.		
"K" STYLE KEYSLOT		"D" STYLE KEYSLOT									Right Hand	Left Hand	Right Hand	Left Hand	
M	N	R +.010 -000	M +.005 -000	N +.005 -000						Min.	Max.				
-	.055 - .065	.078	.062	.110	10	.045	3,000	1,100	150	.5	6	M81935/9-03	M81935/9-03L	ASW-3ET	ASG-3ET
-	.055 - .065	.078	.062	.110	10	.060	5,500	1,300	430	.5	6	M81935/9-04	M81935/9-04L	ASW-4ET	ASG-4ET
-	.055 - .065	.078	.062	.110	10	.100	8,900	2,000	700	1	15	M81935/9-05	M81935/9-05L	ASW-5ET	ASG-5ET
-	.055 - .065	.078	.093	.110	9	.145	13,400	3,100	1,100	1	15	M81935/9-06	M81935/9-06L	ASW-6ET	ASG-6ET
-	.055 - .065	.078	.093	.110	8	.215	18,200	4,200	1,400	1	15	M81935/9-07	M81935/9-07L	ASW-7ET	ASG-7ET
-	.055 - .065	.078	.093	.110	8	.305	24,600	5,700	2,040	1	15	M81935/9-08	M81935/9-08L	ASW-8ET	ASG-8ET
.125 - .130	.077 - .082	-	.125	.110	8	.550	39,500	9,200	2,430	1	15	M81935/9-10	M81935/9-10L	ASW-10ET	ASG-10ET
.125 - .130	.077 - .082	-	.125	.110	8	.930	57,200	13,500	2,940	1	15	M81935/9-12	M81935/9-12L	ASW-12ET	ASG-12ET
.156 - .161	.086 - .091	-	.156	.110	8	1.390	77,800	18,400	3,100	1	24	M81935/9-14	M81935/9-14L	ASW-14ET	ASG-14ET
.156 - .161	.094 - .099	-	.156	.110	9	1.975	101,000	24,000	3,570	1	24	M81935/9-16	M81935/9-16L	ASW-16ET	ASG-16ET

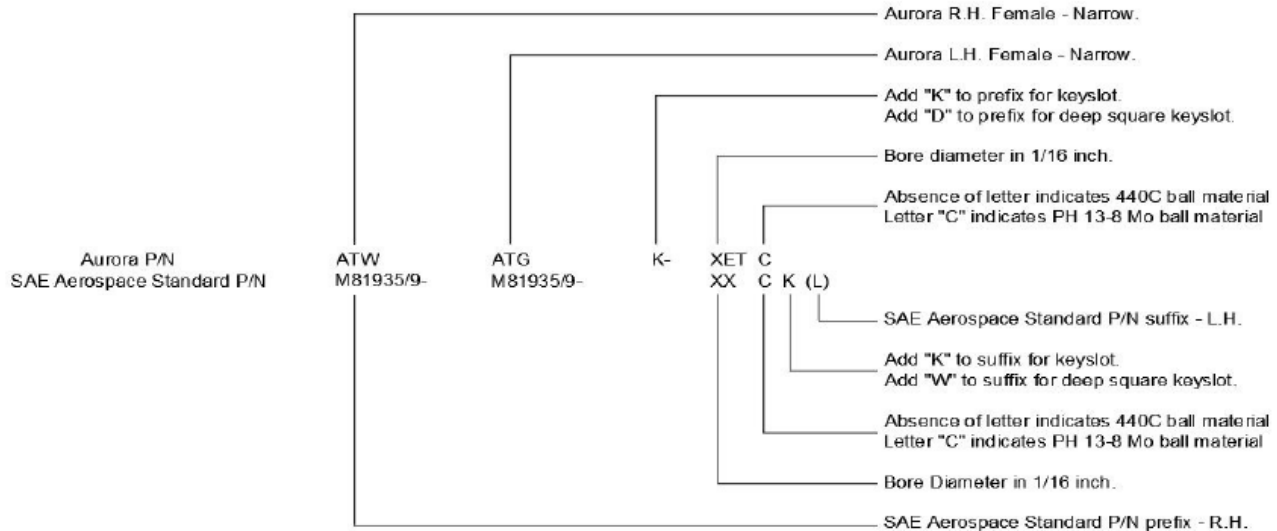

Effective August 21st, 2023, the Naval Air Warfare Center Aircraft Division (NAWCAD) has disapproved Timken Aurora's qualification status for SAE-AS81820 and SAE-AS81935 specifications. Timken Aurora is working diligently to get requalified.



# AJB-TA/TC STRAIGHT JOURNAL BEARINGS

SAE-AS81934/1

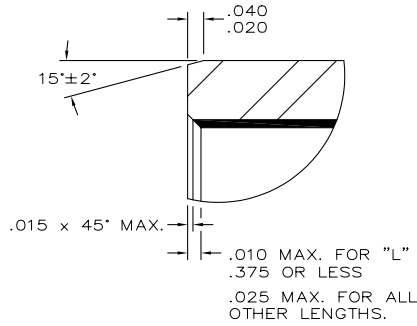

**DETAIL A**

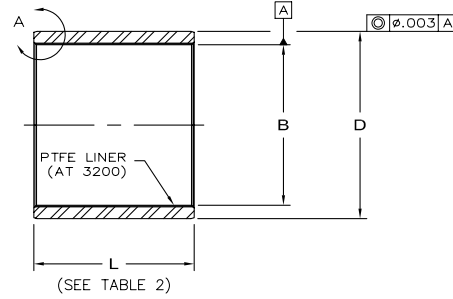

BEARING NO.		DIMENSIONS IN INCHES			Weight* Lbs./Inch (Ref) L=1.000	
Aluminum	Stainless Steel	B +.0000 -.0010	D		Alum.	CRES
			± .0005	D +.0000 -.0005		
AJB-4TA	AJB-4TC	.2515		.3760	.006	.016
AJB-5TA	AJB-5TC	.3140		.4386	.007	.019
AJB-6TA	AJB-6TC	.3765		.5012	.008	.022
AJB-7TA	AJB-7TC	.4390		.5638	.009	.025
AJB-8TA	AJB-8TC	.5015		.6265	.011	.028
AJB-9TA	AJB-9TC	.5640		.6892	.012	.031
AJB-10TA	AJB-10TC	.6265		.8142	.021	.056
AJB-11TA	AJB-11TC	.6890		.8767	.022	.060
AJB-12TA	AJB-12TC	.7515		.9393	.024	.065
AJB-14TA	AJB-14TC	.8765		1.0645	.028	.075
AJB-16TA	AJB-16TC	1.0015		1.1898	.031	.084
AJB-18TA	AJB-18TC	1.1265		1.3148	.035	.094
AJB-20TA	AJB-20TC	1.2515		1.4398	.038	.103
AJB-22TA	AJB-22TC	1.3765		1.5648	.041	.113
AJB-24TA	AJB-24TC	1.5015		1.7523	.062	.171
AJB-26TA	AJB-26TC	1.6265		1.8773	.067	.183
AJB-28TA	AJB-28TC	1.7515		2.0023	.071	.193
AJB-32TA	AJB-32TC	2.0015		2.2523	.081	.222

timkenaurorabearing.com • Fax 630-859-0971

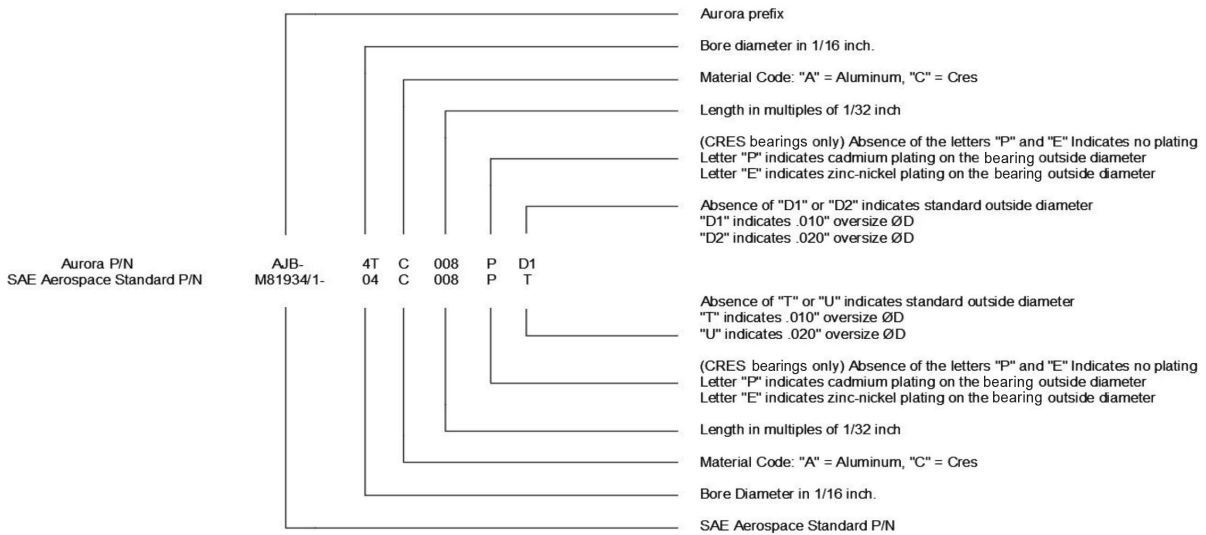

\*Example of weight calculation: AJB-16TA-008: (.031 lb/in) x .250 = .008 lbs.

# AJB-TA/TC STRAIGHT JOURNAL BEARINGS

SAE-AS81934/1



SPECIFICATIONS	
"A"	Aluminum alloy AMS-QQ-A-200/3 or AMS-QQ-A-225/6 (2024T851 or 2024T8511), chemical film treatment per MIL-DTL-5541
"C"	Corrosion resistant steel, AMS 5643 (17-4 PH) Condition H-1150 per AMS-H-6875, Passivated per AMS 2700 or ASTM A 967 (Cad, or Zinc-Nickel plate optional)
"T"	AT 3200 Bearing Liner System, permanently bonded to bearing I.D. qualified to SAE-AS81820 Type A

TABLE 2A

DASH NO.	NOMINAL SIZE	Length L <sup>+0.00</sup> / <sub>-.010</sub>														
		.156	.187	.218	.250	.281	.312	.343	.375	.437	.500	.562	.625	.687	.750	.875
-04	1/4	005	006	007	008	009	010	011	012	014						
-05	5/16	005	006	007	008	009	010	011	012	014	016	018				
-06	3/8	005	006	007	008	009	010	011	012	014	016	018	020	022		
-07	7/16	005	006	007	008	009	010	011	012	014	016	018	020	022	024	028
-08	1/2	005	006	007	008	009	010	011	012	014	016	018	020	022	024	028
-09	9/16	005	006	007	008	009	010	011	012	014	016	018	020	022	024	028
-10	5/8	005	006	007	008	009	010	011	012	014	016	018	020	022	024	028
-11	11/16				008	009	010	011	012	014	016	018	020	022	024	028
-12	3/4				008	009	010	011	012	014	016	018	020	022	024	028
-14	7/8				008	009	010	011	012	014	016	018	020	022	024	028
-16	1				008	009	010	011	012	014	016	018	020	022	024	028
-18	1 1/8						010	011	012	014	016	018	020	022	024	028
-20	1 1/4								012	014	016	018	020	022	024	028
-22	1 3/8								012	014	016	018	020	022	024	028
-24	1 1/2								012	014	016	018	020	022	024	028
-26	1 5/8										016	018	020	022	024	028
-28	1 3/4										016	018	020	022	024	028
-32	2										016	018	020	022	024	028

TABLE 2B

DASH NO.	NOMINAL SIZE	Length L <sup>+0.00</sup> / <sub>-.010</sub>														
		1.000	1.125	1.250	1.375	1.500	1.625	1.750	1.875	2.000	2.125	2.250	2.375	2.500	2.750	3.000
-04	1/4															
-05	5/16															
-06	3/8															
-07	7/16															
-08	1/2															
-09	9/16	032	036													
-10	5/8	032	036	040	044											
-11	11/16	032	036	040	044	048	052									
-12	3/4	032	036	040	044	048	052									
-14	7/8	032	036	040	044	048	052									
-16	1	032	036	040	044	048	052	056	060							
-18	1 1/8	032	036	040	044	048	052	056	060							
-20	1 1/4	032	036	040	044	048	052	056	060	064	068					
-22	1 3/8	032	036	040	044	048	052	056	060	064	068					
-24	1 1/2	032	036	040	044	048	052	056	060	064	068	072	076	080	088	
-26	1 5/8	032	036	040	044	048	052	056	060	064	068	072	076	080	088	096
-28	1 3/4	032	036	040	044	048	052	056	060	064	068	072	076	080	088	096
-32	2	032	036	040	044	048	052	056	060	064	068	072	076	080	088	096

Stainless Steel parts (suffix "C") are available Cadmium plated (Suffix "P") or Zinc - Nickel plated (Suffix "E")

Ex.: AJB-4TC-008P or AJB-4TC-008E. Consult factory for full specifications.

Oversize Outside Diameter (dimension "D") parts per Military spec. suffix "T" (+.010") and suffix "U" (+.020") are available

Add suffix "D1" to specify .010" oversize, "D2" to specify .020" oversize. Ex.: AJB-4TC-008D1 or AJB-4TC-008D2.

Consult factory for full specifications. Weight calculations listed are valid for standard Outside Diameter parts only.



# AJB-TFA-TFC FLANGED JOURNAL BEARINGS

SAE-AS81934/2

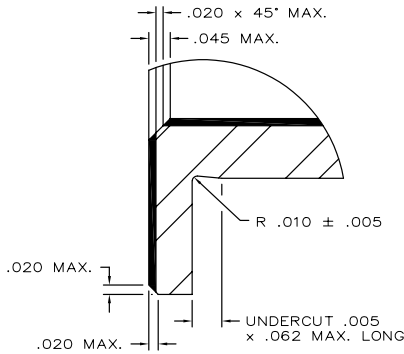

DETAIL A

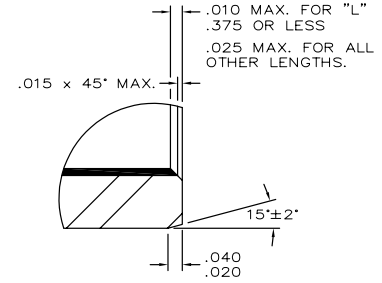
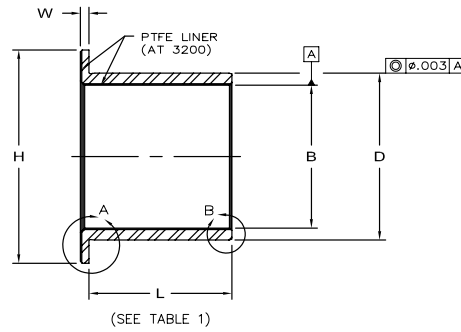

DETAIL B

BEARING NO.		DIMENSIONS IN INCHES					Weight* Lbs./Inch (Ref) L=1.000		Flange Weight Lbs. (Ref)	
Aluminum	Stainless Steel	B	D	D	H	W	Alum.	CRES	Alum.	CRES
		+0.000 -0.010	± .0005	+0.000 -0.005	+ .000 - .020	+ .000 - .005				
AJB-4TFA	AJB-4TFC	.2515	.3760		.750	.0625	.006	.016	.002	.006
AJB-5TFA	AJB-5TFC	.3140	.4386		.812	.0625	.007	.019	.003	.007
AJB-6TFA	AJB-6TFC	.3765	.5012		.875	.0625	.008	.022	.003	.007
AJB-7TFA	AJB-7TFC	.4390	.5638		.937	.0625	.009	.025	.003	.008
AJB-7TFHA	AJB-7TFHC	.4390	.5638		.745	.0625	.009	.025	.003	.008
AJB-8TFA	AJB-8TFC	.5015	.6265		1.000	.0625	.011	.028	.003	.009
AJB-9TFA	AJB-9TFC	.5640	.6892		1.125	.0625	.012	.031	.004	.011
AJB-10TFA	AJB-10TFC	.6265	.8142		1.250	.0625	.021	.056	.005	.014
AJB-11TFA	AJB-11TFC	.6890	.8767		1.375	.0625	.022	.060	.006	.016
AJB-12TFA	AJB-12TFC	.7515	.9393		1.500	.0625	.024	.065	.007	.020
AJB-14TFA	AJB-14TFC	.8765	1.0645		1.625	.0625	.028	.075	.008	.022
AJB-16TFA	AJB-16TFC	1.0015	1.1898		1.750	.0625	.031	.084	.009	.024
AJB-18TFA	AJB-18TFC	1.1265	1.3148		1.875	.0937	.035	.094	.015	.041
AJB-20TFA	AJB-20TFC	1.2515	1.4398		2.000	.0937	.038	.103	.016	.045
AJB-22TFA	AJB-22TFC	1.3765	1.5648		2.125	.0937	.041	.113	.017	.048
AJB-24TFA	AJB-24TFC	1.5015	1.7523		2.250	.0937	.062	.171	.018	.051
AJB-26TFA	AJB-26TFC	1.6265	1.8773		2.375	.0937	.067	.183	.020	.055
AJB-28TFA	AJB-28TFC	1.7515	2.0023		2.500	.0937	.071	.193	.021	.058
AJB-32TFA	AJB-32TFC	2.0015	2.2523		2.750	.0937	.081	.222	.023	.065

timkenaurorabearing.com • Fax 630-859-0971

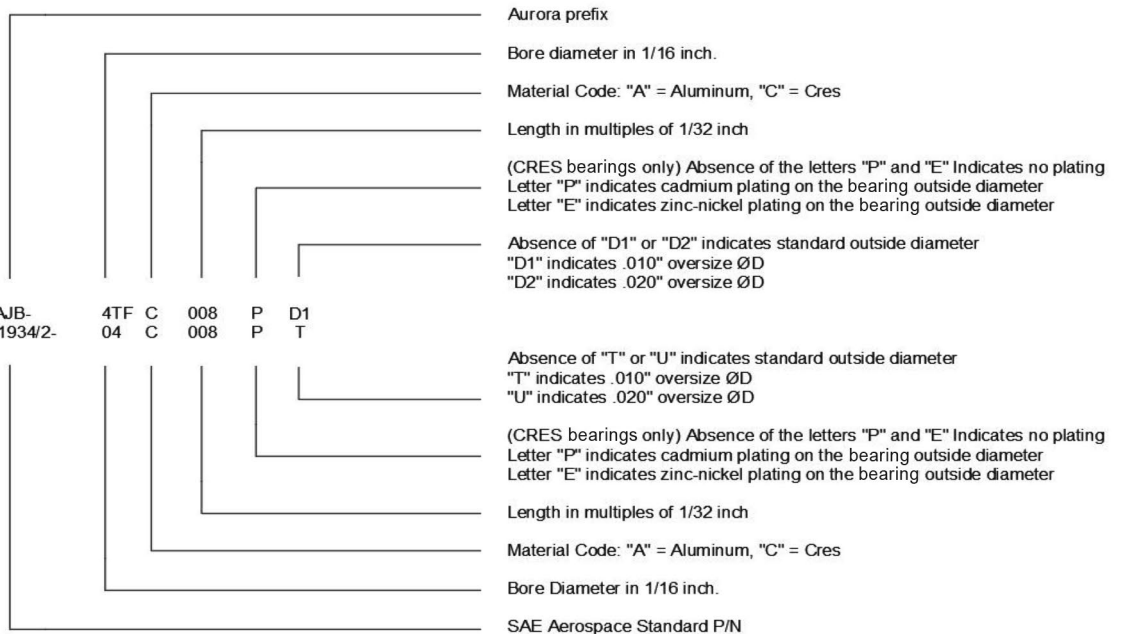

\* Example of weight calculation: AJB-16TFA-016:  
 Sleeve Weight: (.031 lb/in) x .500 = .0155 lbs  
 Flange weight = .009 lbs  
 Total weight = .0245 lbs

# AJB-TFA/TFC FLANGED JOURNAL BEARINGS

SAE-AS81934/2



SPECIFICATIONS	
<b>“A”</b>	Aluminum alloy AMS-QQ-A-200/3 or AMS-QQ-A-225/6 (2024T851 or 2024T8511), chemical film treatment per MIL-DTL-5541
<b>“C”</b>	Corrosion resistant steel, AMS 5643 (17-4 PH) Condition H-1150 per AMS-H-6875, Passivated per AMS 2700 or ASTM A967 (Cad, or Zinc-Nickel plate optional)
<b>“T”</b>	AT 3200 Bearing Liner System, permanently bonded to bearing I.D. qualified to SAE-AS81820 Type A

**TABLE 1A**

DASH NO.	NOMINAL SIZE	Length L <sup>+0.00</sup> / <sub>-.010</sub>														
		.156	.187	.218	.250	.281	.312	.343	.375	.437	.500	.562	.625	.687	.750	.875
-04	1/4	005	006	007	008	009	010	011	012	014						
-05	5/16	005	006	007	008	009	010	011	012	014	016	018				
-06	3/8	005	006	007	008	009	010	011	012	014	016	018	020	022		
-07	7/16	005	006	007	008	009	010	011	012	014	016	018	020	022	024	028
-08	1/2	005	006	007	008	009	010	011	012	014	016	018	020	022	024	028
-09	9/16	005	006	007	008	009	010	011	012	014	016	018	020	022	024	028
-10	5/8	005	006	007	008	009	010	011	012	014	016	018	020	022	024	028
-11	11/16				008	009	010	011	012	014	016	018	020	022	024	028
-12	3/4				008	009	010	011	012	014	016	018	020	022	024	028
-14	7/8				008	009	010	011	012	014	016	018	020	022	024	028
-16	1				008	009	010	011	012	014	016	018	020	022	024	028
-18	1 1/8						010	011	012	014	016	018	020	022	024	028
-20	1 1/4								012	014	016	018	020	022	024	028
-22	1 3/8								012	014	016	018	020	022	024	028
-24	1 1/2								012	014	016	018	020	022	024	028
-26	1 5/8										016	018	020	022	024	028
-28	1 3/4										016	018	020	022	024	028
-32	2										016	018	020	022	024	028

**TABLE 1B**

DASH NO.	NOMINAL SIZE	Length L <sup>+0.00</sup> / <sub>-.010</sub>														
		1.000	1.125	1.250	1.375	1.500	1.625	1.750	1.875	2.000	2.125	2.250	2.375	2.500	2.750	3.000
-04	1/4															
-05	5/16															
-06	3/8															
-07	7/16															
-08	1/2															
-09	9/16	032	036													
-10	5/8	032	036	040	044											
-11	11/16	032	036	040	044	048	052									
-12	3/4	032	036	040	044	048	052									
-14	7/8	032	036	040	044	048	052									
-16	1	032	036	040	044	048	052	056	060							
-18	1 1/8	032	036	040	044	048	052	056	060							
-20	1 1/4	032	036	040	044	048	052	056	060	064	068					
-22	1 3/8	032	036	040	044	048	052	056	060	064	068					
-24	1 1/2	032	036	040	044	048	052	056	060	064	068	072	076	080	088	
-26	1 5/8	032	036	040	044	048	052	056	060	064	068	072	076	080	088	096
-28	1 3/4	032	036	040	044	048	052	056	060	064	068	072	076	080	088	096
-32	2	032	036	040	044	048	052	056	060	064	068	072	076	080	088	096

Stainless Steel parts (suffix “C”) are available Cadmium plated (Suffix “P”) or Zinc - Nickel plated (Suffix “E”)

Ex.: AJB-4TFC-008P or AJB-4TFC-008E. Consult factory for full specifications.

Oversize Outside Diameter (dimension “D”) parts per Military spec. suffix “T” (+.010”) and suffix “U” (+.020”) are available

Add suffix “D1” to specify .010” oversize, “D2” to specify .020” oversize. Ex.: AJB-4TFC-008D1 or AJB-4TFC-008D2.

Consult factory for full specifications. Weight calculations listed are valid for standard Outside Diameter parts only.

Effective August 21st, 2023, the Naval Air Warfare Center Aircraft Division (NAWCAD) has disapproved Timken Aurora’s qualification status for SAE-AS81820 and SAE-AS81935 specifications. Timken Aurora is working diligently to get requalified.

timkenaurorabearing.com • Fax 630-859-0971



# GMM-M & GMB-M SERIES MALE ROD ENDS

General Aviation - Precision

timkenaurorabearing.com • Fax 630-859-0971

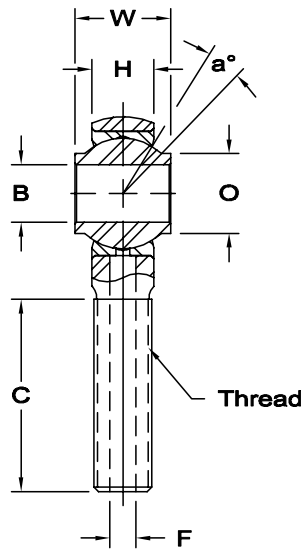
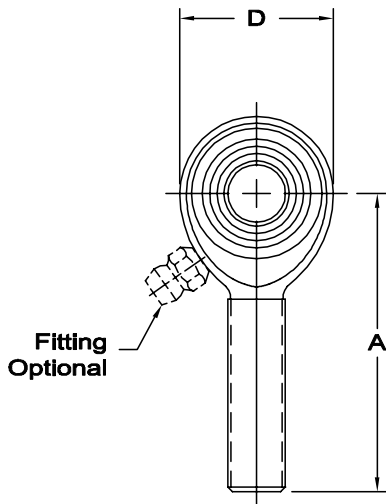

**DETAIL "A"**

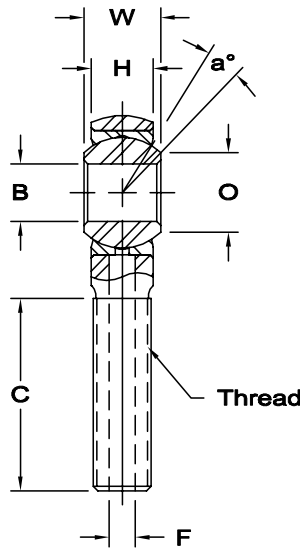
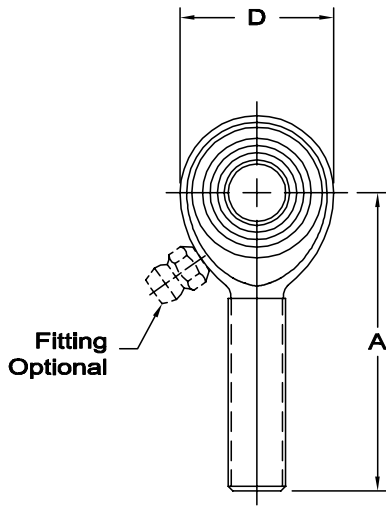

**DETAIL "B"**



**Body** - Low carbon steel, protective coated for corrosion resistance.

**Race** - Low carbon steel, protective coated for corrosion resistance.

**Ball** - Alloy steel, heat treated, hard chrome plated.

**Notes** - Units are magnetic particle inspected after assembly.

Load ratings apply only to rod ends without grease fittings. For load ratings with fittings, please contact our engineering department.

Units are supplied without grease fittings. When a grease fitting is required, specify by adding suffix as designated.

Z Zerk type fitting                      Ex: GMM-3MZ-470  
 F Flush type fitting                      Ex: GMM-3MF-470

BEARING NO.		DIMENSIONS IN INCHES											a° Misalign. Angle	Ultimate Radial Static Load Capacity Lbs.	Approx. Brg. Wt. Lbs.
Right Hand	Left Hand	Ball Shoulder Configuration	B + .0015 - .0005	W + .000 - .005	H ±.005	A ±.015	D ±.010	O Shoulder Dia. Ref.	Ball Dia. Ref.	C Min.	F Drilled Hole Dia ref	Thread UNF-3A			
GMM-3M-470	GMB-3M-470	See Detail "A"	.1900	.437	.281	1.562	.750	.315	.500	.969	-	1/4-28	17	2,158	.05
GMM-3M-570	GMB-3M-570	See Detail "A"	.1900	.437	.328	1.375	.875	.315	.500	.750	.113	5/16-24	10	2,823	.07
GMM-3M-670	GMB-3M-670	See Detail "A"	.1900	.437	.328	1.375	.750	.315	.500	.750	.113	3/8-24	10	2,850	.08
GMM-3M-680	GMB-3M-680	See Detail "B"	.1900	.500	.375	1.812	.833	.319	.593	1.062	.136	3/8-24	18	3,269	.09
GMM-4M-470	GMB-4M-470	See Detail "B"	.2500	.437	.304	1.562	.812	.353	.562	.969	-	1/4-28	18	2,158	.07
GMM-4M-675	GMB-4M-675	See Detail "B"	.2500	.484	.335	2.312	.875	.395	.625	1.500	.136	3/8-24	18	3,160	.11
GMM-4M-680	GMB-4M-680	See Detail "B"	.2500	.500	.335	2.062	.875	.375	.625	1.500	.159	3/8-24	21	2,985	.10



# GMW-M & GMG-M SERIES FEMALE ROD ENDS

General Aviation - Precision



**DETAIL  
"A"**

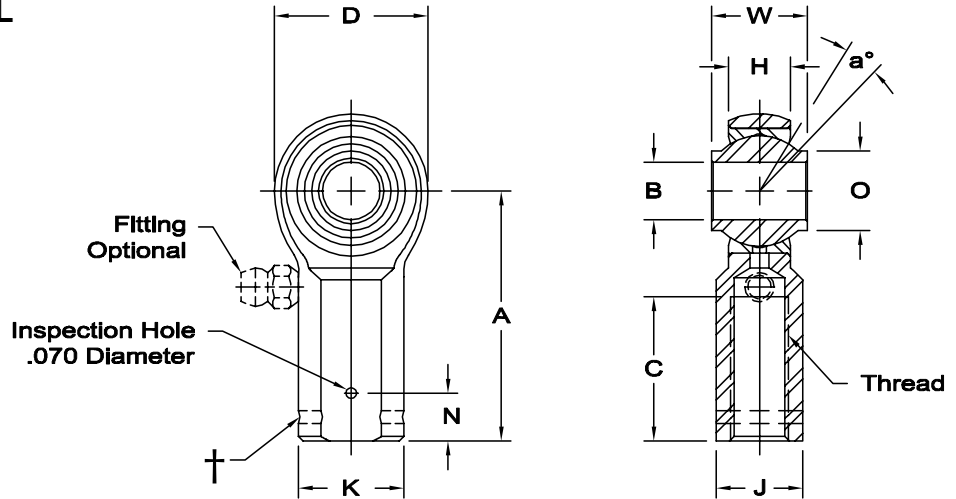

**DETAIL  
"B"**

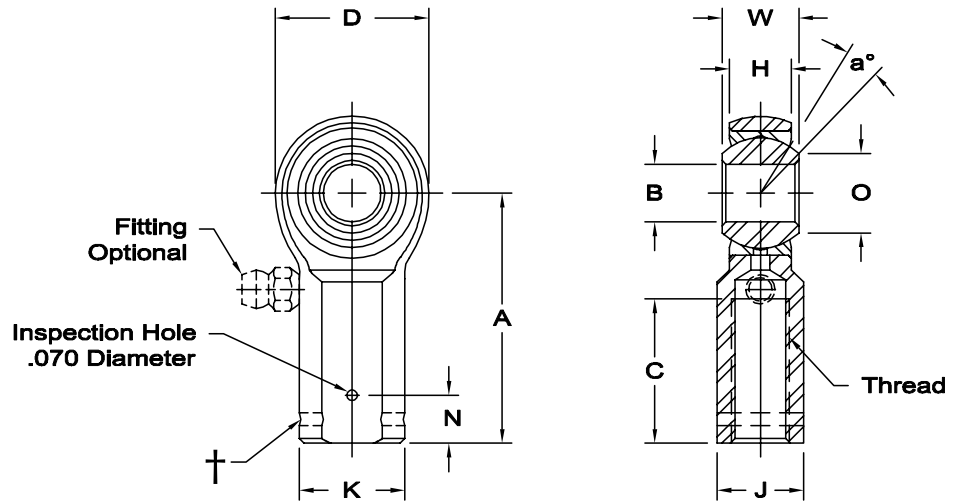

**Body** - Low carbon steel, protective coated for corrosion resistance.

**Race** - Low carbon steel, protective coated for corrosion resistance.

**Ball** - Alloy steel, heat treated, hard chrome plated.

**Notes** - Units are magnetic particle inspected after assembly.

† Left hand units identification groove near end of shank.

Units are supplied without grease fittings. When a grease fitting is required, specify by adding suffix as designated.

Z Zerk type fitting

Ex: GMW-3MZ-470

F Flush type fitting

Ex: GMW-3MF-470

Load ratings apply only to rod ends without grease fittings. For load ratings with fittings, please consult our engineering department.

BEARING NO.		DIMENSIONS IN INCHES													a° Misalign. Angle	Ultimate Radial Static Load Capacity Lbs.	Approx. Brg. Wt. Lbs.
Right Hand	Left Hand†	Ball Shoulder Configuration	B +.0015 -.0005	W +.000 -.005	H ±.005	A ±.015	D ±.010	K ±.010	J ±.010	N ±.005	O Shoulder Dia. Ref.	Ball Dia. Ref.	C +.062 -.031	Thread UNF- 3B			
GMW-3M-470	GMG-3M-470	See Detail "A"	.1900	.437	.328	1.375	.750	.468	.375	.312	.315	.500	.750	1/4-28	10	2,881	.06
GMW-3M-471	GMG-3M-471	See Detail "A"	.1900	.437	.328	1.062	.750	.375	-	-	.315	.500	.437	1/4-28	10	2,881	.05
GMW-3M-480	GMG-3M-480	See Detail "A"	.1900	.500	.375	1.375	.812	.468	.375	.312	.312	.562	.750	1/4-28	15	3,152	.08
GMW-3M-570	GMG-3M-570	See Detail "A"	.1900	.437	.328	1.375	.750	.500	.437	.312	.315	.500	.750	5/16-24	10	2,881	.07
GMW-4M-470	GMG-4M-470	See Detail "B"	.2500	.437	.304	1.375	.812	.468	.375	.312	.353	.562	.750	1/4-28	18	2,950	.08
GMW-4M-595	GMG-4M-595	See Detail "A"	.2500	.593	.406	1.469	.938	.500	.437	.312	.485	.687	.844	5/16-24	10	3,359	.10

timkenaurorabearing.com • Fax 630-859-0971



# AIRCRAFT AND MILITARY SPECIAL PRODUCTS

Beyond Aurora standard catalog offerings, Timken Aurora Bearing has the capability to design, engineer, and manufacture special bearings and linkage assemblies. This is a small sample of items Aurora has produced for Aircraft and Military customers.



timkenaurorabearing.com • Fax 630-859-0971

Parts commonly used in the race car industry, in non standard sizes and dimensions, along with common part number references. While not cataloged with standard parts series, many of these are stocked. Check with dealer or factory for availability.

timkenaurorabearing.com • Fax 630-859-0971

Aurora part number	Common part number	B	H	W	D	A	Thread	Description/note
AM-4T-9	RC04	0.2500	0.281	0.375	0.7500	1.562	5/16-24	
AM-6T-6	2057P	0.3750	0.406	0.500	1.0000	1.938	1/2-20	
AM-6T-7		0.3750	0.500	0.625	1.3120	2.438	5/8-18	
AM-6T-15	1865P	0.3750	0.500	0.625	1.3120	2.438	1/2-20	
AM-12-2		0.7500	0.875	0.875	1.7500	2.875	3/4-16	Solid rod eye
AM-12T-22		0.7500	0.687	0.875	1.7500	2.875	7/8-14	Heat treated race
ATM-8T	MNR08U	0.5000	0.395	0.500	1.4590	2.544	1/2-20	
ATM-10T	MNR10U	0.6250	0.505	0.625	1.7630	2.832	5/8-18	
CM-12-12		0.7570	0.593	0.875	1.7500	2.875	3/4-16	
COM-8T-7	21CNZ081	0.5000	0.375	0.437	0.8750			Heat treated race
COM-8T-18	3087P	0.5000	0.400	0.750	1.1875			
COM-8T-20	1243P	0.5000	0.375	0.437	0.8750			Mild steel race
COM-8T-33	RBJ 205L	0.5000	0.3125	0.437	0.9375			HT race, PTFE lined
COM-8T-45		0.5000	0.390	1.000	1.0000			Drag Shocks
COM-10T-18	2280P	0.6250	0.630	0.875	1.3750			
COM-10T-32		0.6250	0.567	0.875	1.3750			
COM-12T-34		0.7500	0.593	0.750	1.4375			All Aluminum
CW-M2E-1		2.00 MM	2.24 MM	4.5MM	6.9 MM	12.45MM	M3X.5	
HAB-3T	ABYT-3	0.1900	.210	0.500	0.5625			HAB-3TG = ABYT-3V
HAB-5TG-3	ABYT-5V	0.3125	0.255	0.625	0.6875			
HAB-12T-11		0.7500	0.615	1.280	1.5625			
HCOM-24ET-8	AKW24V-4010	1.5000	1.500	1.960	2.9170			286,551 RSLC
HXAM-3T	ARYT-3	0.1900	.220	0.500	0.8060	1.562	5/16-24	
HXAM-6T-4		0.3750	0.355	0.813	1.1500	2.125	3/8-24	High Misalignment
HXAM-8T-8		0.5000	0.411	0.937	1.5250	2.625	1/2-20	High Misalignment
LCOM-8T	LS8, RS8	0.5000	0.531	0.687	1.3125			
LCOM-10T	LS10, RS10	0.6250	0.687	0.875	1.5625			
M-8B-FI-1		0.5000	0.390	0.625	1.0590			
MIB-4T-4		0.2500	0.281	0.375	0.6000			Mt bike shock
PRXM-5T-1		0.3125	0.327	0.437	1.0250	2.687	7/16-20	
PRXM-6T-4		0.3750	0.416	0.500	1.2500	2.750	1/2-20	
PRXM-7T-1		0.4375	0.452	0.562	1.2450	2.500	1/2-20	
PWB-8T-3	RWR08D/E	0.5000	0.500	0.750	1.1250			
PWB-12T-4		0.7500	0.625	0.750	1.3750			
RAM-8T-5		0.5000	0.687	0.750	1.7500	2.875	3/4-16	Ball dia 1.312
RXAM-8T-3		0.5000	0.562	0.750	1.7500	2.875	3/4-16	Ball dia. 1.125
RXAM-12T-1		0.7500	0.687	0.875	2.0000	3.375	7/8-14	
RAM-14T-1		0.8750	0.765	0.875	2.0000	3.375	7/8-14	
RXAM-14T-1		0.8750	0.765	0.875	2.3250	3.500	1-14	84,897 lb. RSLC
RAM-16T-1		1.0000	1.000	1.375	2.7750	4.125	1-14	100,643 lb. RSLC
RAM-16T-3		1.0000	1.000	1.375	2.7750	4.125	1 1/4-12	100,643 lb. RSLC
XAM-6T-1	1560P	0.3750	0.406	0.500	1.3120	2.438	1/2-20	
XAM-8T-2		0.5000	0.562	0.750	1.7500	2.875	3/4-16	
XAM-8T-5	MNR08U	0.5000	0.406	0.500	1.3120	2.438	1/2-20	
XAM-8T-10		0.5000	0.562	0.750	1.7500	2.625	5/8-18	
XAM-8T-11		0.5000	0.562	0.750	1.5000	2.625	5/8-18	
XCM-8		0.5000	0.453	0.625	1.5000	2.625	5/8-18	2 piece. Lined:VXCM-8

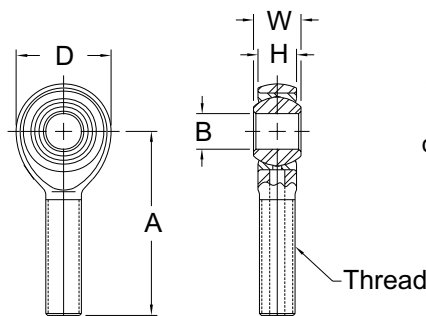

**NOTE:**  
Dimensions and descriptions are for reference only, and may not fully reflect part specifications. Check catalog or factory for related material specifications, tolerances, etc.

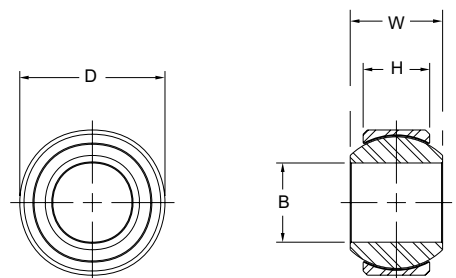



# SPECIAL SIZE RACE CAR SPHERICAL BEARINGS

Parts commonly used in the race car industry, along with common part number references. While not cataloged, many of these parts are stocked. Check with dealer or factory for availability

## SHOCK ABSORBER BEARINGS

Bearings used in motorsports shock absorbers or dampers, both as standard, and for common special applications.

Aurora Part #	Description/Application	B	D	W	H
COM-6T-20	52100 eared ball	0.3750	1.0000	0.9965	0.3900
COM-6T-24	7075 Aluminum eared ball	0.3750	1.0000	0.9965	0.3900
COM-6T-25	7075 Aluminum eared ball	0.3750	1.0000	0.8750	0.3900
GEZ008ES	Fractured race metal on metal	0.5000	0.8750	0.4370	0.3750
GEZ008C	GEZ008ES size "+1 quality" economy PTFE lined	0.5000	0.8750	0.4370	0.3750
COM-8T-20	GEZ008ES "+2", LC swaged race ptfе lined	0.5000	0.8750	0.4370	0.3750
COM-8T-7	Heat treated swaged race ptfе lined	0.5000	0.8750	0.4370	0.3750
COM-8		0.5000	1.0000	0.5000	0.3900
COM-8T		0.5000	1.0000	0.5000	0.3900
COM-8TKH	4130 HT race, AT1400 liner	0.5000	1.0000	0.5000	0.3900
PNB-8T	17-4 Heat treated race, AT3200 liner	0.5000	1.0000	0.5000	0.3900
COM-8-53	COM-8 with .625" W.	0.5000	1.0000	0.6250	0.3900
COM-8T-35	COM-8T with .625" W	0.5000	1.0000	0.6250	0.3900
COM-8T-45	Eared ball, common drag shock bearing	0.5000	1.0000	1.0000	0.3900
COM-8T-48	Eared ball	0.5000	1.0000	0.8750	0.3900
COM-8T-55	US "oval track" shocks	0.5000	1.0600	0.6250	0.3840
COM-8T-63	15MM. shocks to US Drag Race	0.5000	26.0000	1.0000	9.0000
COM-8T-64	15MM shock to COM-8T application	0.5000	26.0000	0.5000	9.0000
COM-8T-24	GE15 race dimension, 1/2" bore, .625"W"	0.5000	26.0000	0.6250	9.0000
COM-8TKH-9	COM-8T-24 Dim. Heat treated race	0.5000	26.0000	0.6250	9.0000
GE15ES	Metal on metal 15mm Fractured Race	15.0000	26.0000	12.0000	9.0000
GE15C	15mm PTFE lined	15.0000	26.0000	12.0000	9.0000
GE15ET-2RS	Fractured race, ptfе lined, seals	15.0000	26.0000	12.0000	9.0000
COM-M15T-4	Swaged L. C. race, AT1400 liner	15.0000	26.0000	12.0000	9.0000
COM-M15TKH-1	Swaged Heat treated race, AT1400 liner	15.0000	26.0000	12.0000	9.0000
COM-M15T-6	COM-8T w 15mm bore Convert COM-8 shock to 15mm	15.0000	1.0000	12.0000	0.3900
M-8B-FI-1	US oval track economy	0.5000	1.0600	0.6250	0.3900
M-10-FI-5	5/8 bore US oval track	0.6250	1.0600	0.6250	0.3900

Dimensions nominal, in inches or *metric*. Consult factory for more complete dimensions.

These are more commonly used parts. Contact factory for interchange to parts not listed, or for custom specials.

## METRIC RACE CAR PTFE LINED SPHERICAL BEARINGS

Aurora Part Number	Common Part Number	B	H	W	D
AIB-M12T-1	G-12D	12	12	16	26
GE12C	GE12E	12	7	10	22
COM-M14T-3		14	10	19	28
HAB-M14TG-1	MBYT-14V	14	10	23.5	29
GE15C	GE15ES	15	9	12	26
COM-M15T-4	GE15ES	15	9	12	26
COM-M15T-8	GEH15ES	15	10	16	30
AIB-M16T-1	G-16D	16	15	21	32
HAB-M16TG-1	MBYT-16V	16	14	30.5	35
GEG17ET-2RS	GEG17ES	17	12	20	35
AIB-M20T-1	G-20D	20	18	25	40
GEG20ET-2RS	GEG20ES	20	16	25	42
GEG25ET-2RS	GEG25ES	25	18	28	47

Dimensions are for reference only, and may not fully reflect actual part specifications. Check catalog or factory for related series material specifications, tolerances, etc.

Information to assist in the installation of rod ends and spherical bearings, and to provide assistance in their usage. Frequently asked questions regarding rod ends and spherical bearings are also addressed.

## **timkenaurorabearing.com** **Not Just a Site, A Technical Resource Center**

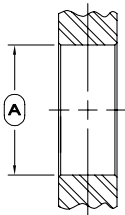

## COM & HCOM Series

BEARING SERIES COM HCOM	DIMENSIONS IN INCHES				
	Ⓐ Suggested Housing Bore For Press Fit of Spherical Bearings				
	Bearing Outside Diameter +.0000 -.0007	Steel Housing		Aluminum Housing	
Max.		Min.	Max.	Min.	
3	.5625	.5619	.5614	.5618	.5612
4	.6562	.6556	.6551	.6555	.6549
5	.7500	.7494	.7489	.7493	.7487
6	.8125	.8119	.8114	.8118	.8112
7	.9062	.9056	.9051	.9055	.9049
8	1.0000	.9994	.9989	.9993	.9987
9	1.0937	1.0931	1.0925	1.0930	1.0923
10	1.1875	1.1869	1.1863	1.1868	1.1861
12	1.4375	1.4369	1.4363	1.4368	1.4361
14	1.5625	1.5619	1.5613	1.5618	1.5611
16	1.7500	1.7494	1.7486	1.7493	1.7485
16	2.0000	1.9994	1.9986	1.9993	1.9985
19	2.3750	2.3744	2.3736	2.3743	2.3735
20	2.3750	2.3744	2.3736	2.3743	2.3735
24	2.7500	2.7494	2.7486	2.7493	2.7485
28	3.1250	3.1244	3.1236	3.1243	3.1235
32	3.5000	3.4994	3.4986	3.4993	3.4985

BEARING SERIES COM HCOM	DIMENSIONS IN MILLIMETERS				
	Ⓐ Suggested Housing Bore For Press Fit of Spherical Bearings				
	Bearing Outside Diameter +.000 -.018	Steel Housing		Aluminum Housing	
Max.		Min.	Max.	Min.	
3	14.288	14.272	14.260	14.270	14.255
4	16.667	16.652	16.640	16.650	16.634
5	19.050	19.035	19.022	19.032	19.017
6	20.638	20.622	20.610	20.620	20.604
7	23.018	23.002	22.990	23.000	22.985
8	25.400	25.385	25.372	25.382	25.367
9	27.780	27.765	27.750	27.762	27.744
10	30.162	30.147	30.132	30.145	30.127
12	36.512	36.497	36.482	36.495	36.477
14	39.688	39.672	39.657	39.670	39.652
16	44.450	44.435	44.414	44.432	44.412
16	50.800	50.785	50.764	50.782	50.762
19	60.325	60.310	60.289	60.307	60.287
20	60.325	60.310	60.289	60.307	60.287
24	69.850	69.835	69.814	69.832	69.812
28	79.375	79.360	79.339	79.357	79.337
32	88.900	88.885	88.864	88.882	88.862

Dimensions given in the tables below are for bearings fabricated of standard race materials. Should other materials be used, consult our engineering department for modification of these dimensions.

Tables are representative of Metal to Metal parts, please consult our engineering department regarding PTFE lined parts.

## MIB, AIB & SIB Series

BEARING SERIES MIB AIB SIB	DIMENSIONS IN INCHES				
	Ⓐ Suggested Housing Bore For Press Fit of Spherical Bearings				
	Bearing Outside Diameter +.0000 -.0007	Steel Housing		Aluminum Housing	
Max.		Min.	Max.	Min.	
2	.4062	.4062	.4056	.4055	.4049
3	.5312	.5306	.5301	.5305	.5299
4	.6094	.6088	.6083	.6087	.6081
5	.7500	.7494	.7489	.7493	.7487
6	.8437	.8431	.8426	.8430	.8424
7	1.0000	.9994	.9989	.9993	.9987
8	1.0937	1.0931	1.0925	1.0930	1.0923
10	1.3125	1.3119	1.3113	1.3118	1.3111
12	1.5000	1.4994	1.4988	1.4993	1.4986
14	1.6250	1.6244	1.6236	1.6243	1.6235
16	2.1250	2.1244	2.1236	2.1243	2.1235

BEARING SERIES MIB AIB SIB	DIMENSIONS IN MILLIMETERS				
	Ⓐ Suggested Housing Bore For Press Fit of Spherical Bearings				
	Bearing Outside Diameter +.000 -.018	Steel Housing		Aluminum Housing	
Max.		Min.	Max.	Min.	
2	10.310	10.310	10.302	10.300	10.284
3	13.492	13.477	13.465	13.475	13.460
4	15.479	15.464	15.451	15.461	15.446
5	19.050	19.035	19.022	19.032	19.017
6	21.430	21.415	21.402	21.412	21.397
7	25.400	25.385	25.372	25.382	25.367
8	27.780	27.765	27.750	27.762	27.744
10	33.338	33.322	33.307	33.320	33.302
12	38.100	38.085	38.070	38.082	38.064
14	41.275	41.259	41.239	41.257	41.237
16	53.975	53.960	53.939	53.957	53.937

# SUGGESTED HOUSING BORES

LCOM & COM-M Spherical Bearings

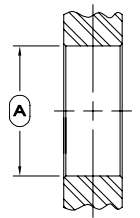

These tables are representative of Metal to Metal parts, please consult our engineering department regarding PTFE lined parts.

## LCOM SERIES

## COM-M SERIES

BEARING SERIES LCOM	DIMENSIONS IN INCHES				
	A Suggested Housing Bore For Press Fit of Spherical Bearings				
	Bearing Outside Diameter +.0000 -.0007	Steel Housing		Aluminum Housing	
Max.		Min.	Max.	Min.	
3	.6250	.6244	.6239	.6243	.6237
4	.7500	.7494	.7489	.7493	.7487
5	.8750	.8744	.8739	.8743	.8737
6	1.0000	.9994	.9989	.999	.9987
7	1.1875	1.1869	1.1863	1.1868	1.1861
8	1.3125	1.3119	1.3113	1.3118	1.3111
10	1.5625	1.5619	1.5613	1.5618	1.5611
12	2.2500	2.2494	2.2486	2.2493	2.2485
12-1	1.8750	1.8744	1.8736	1.8743	1.8735
16	2.3750	2.3744	2.3736	2.3743	2.3735
19	2.6250	2.6244	2.6236	2.6243	2.6235
24	3.2500	3.2494	3.2486	3.2493	3.2485
30	4.0000	3.9994	3.9986	3.9993	3.9985

BEARING SERIES COM-M	DIMENSIONS IN INCHES				
	A Suggested Housing Bore For Press Fit of Metric Spherical Bearings				
	Bearing Outside Diameter +.0000 -.0007	Steel Housing		Aluminum Housing	
Max.		Min.	Max.	Min.	
3	.4724	.4718	.4713	.4717	.4711
5	.6299	.6293	.6288	.6292	.6286
6	.7087	.7081	.7076	.7080	.7074
8	.8661	.8655	.8650	.8654	.8648
10	1.0236	1.0230	1.0225	1.0229	1.0223
12	1.1811	1.1805	1.1799	1.1804	1.1797
14	1.3386	1.3380	1.3374	1.3379	1.3372
16	1.4961	1.4955	1.4949	1.4954	1.4947
18	1.6535	1.6529	1.6523	1.6528	1.6521
20	1.8110	1.8104	1.8096	1.8103	1.8095
22	1.9685	1.9679	1.9671	1.9678	1.9670
25	2.2047	2.2041	2.2033	2.2040	2.2032
30	2.5984	2.5978	2.5970	2.5977	2.5969

BEARING SERIES LCOM	DIMENSIONS IN MILLIMETERS				
	A Suggested Housing Bore For Press Fit of Spherical Bearings				
	Bearing Outside Diameter +.000 -.018	Steel Housing		Aluminum Housing	
Max.		Min.	Max.	Min.	
3	15.875	15.860	15.847	15.857	15.842
4	19.050	19.035	19.022	19.032	19.017
5	22.225	22.210	22.197	22.207	22.192
6	25.400	25.385	25.372	25.382	25.367
7	30.163	30.148	30.132	30.145	30.127
8	33.338	33.323	33.307	33.320	33.302
10	39.688	39.673	39.657	39.670	39.652
12	57.150	57.135	57.114	57.132	57.112
12-1	47.625	47.610	47.589	47.607	47.587
16	60.325	60.310	60.289	60.307	60.287
19	66.675	66.660	66.639	66.657	66.637
24	82.550	82.535	82.514	82.532	82.512
30	101.600	101.585	101.564	101.582	101.562

BEARING SERIES COM-M	DIMENSIONS IN MILLIMETERS				
	A Suggested Housing Bore For Press Fit of Metric Spherical Bearings				
	Bearing Outside Diameter +.000 -.018	Steel Housing		Aluminum Housing	
Max.		Min.	Max.	Min.	
3	12	11.985	11.972	11.982	11.967
5	16	15.985	15.972	15.982	15.967
6	18	17.985	17.972	17.982	17.967
8	22	21.985	21.972	21.982	21.967
10	26	25.985	25.972	25.982	25.967
12	30	29.985	29.969	29.982	29.964
14	34	33.985	33.969	33.982	33.964
16	38	37.985	37.969	37.982	37.964
18	42	41.985	41.969	41.982	41.964
20	46	45.985	45.964	45.982	45.962
22	50	49.985	49.964	49.982	49.962
25	56	55.985	55.964	55.982	55.962
30	66	65.985	65.964	65.982	65.962

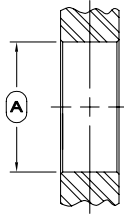

**ISO H7** - Fit recommended for light loads where axial displacement is required after installation.

**ISO M7** - Press fit where bearing is subjected to combination, reversing, or shock loads.

**ISO N7** - Recommended fit when using a light alloy housing (i.e. aluminum).

**EXTRA HEAVY PRESS FIT** - Recommended fit for applications with extreme shock loads that can also tolerate elevated breakaway torques. A sufficiently rigid housing is assumed.

Tables are representative of Metal to Metal parts, please consult our engineering department regarding PTFE lined parts.

For GEG, GEGZ, GEW, GEWZ, GAC, GACZ series, consult factory



DIMENSIONS IN INCHES										
BEARING SERIES GE..ES GEZ..ES..2RS	Ⓐ Suggested Housing Bore For Press Fit of Spherical Plain Bearings									
	Bearing Outside Diameter		ISO H7		ISO M7		ISO N7		Extra Heavy Press Fit	
	Max.	Min.	Max.	Min.	Max.	Min.	Max.	Min.	Max.	Min.
008	.8750	.8745	.8758	.8750	.8750	.8742	.8747	.8739	.8743	.8735
010	1.0625	1.0620	1.0633	1.0625	1.0625	1.0617	1.0622	1.0614	1.0610	1.0620
012	1.2500	1.2495	1.2510	1.2500	1.2500	1.2490	1.2497	1.2487	1.2485	1.2475
014	1.4375	1.4370	1.4385	1.4375	1.4375	1.4365	1.4372	1.4362	1.4360	1.4350
016	1.6250	1.6245	1.6260	1.6250	1.6250	1.6240	1.6247	1.6237	1.6235	1.6225
020	2.0000	1.9995	2.0012	2.0000	2.0000	1.9988	1.9996	1.9985	1.9987	1.9975
022	2.1875	2.1870	2.1887	2.1875	2.1875	2.1863	2.1871	2.1860	2.1862	2.1850
024	2.4375	2.4370	2.4387	2.4375	2.4375	2.4363	2.4371	2.4360	2.4362	2.4350
028	2.8125	2.8120	2.8137	2.8125	2.8125	2.8113	2.8210	2.8110	2.8112	2.8100
032	3.1875	3.1869	3.1889	3.1875	3.1875	3.1861	3.1871	3.1857	3.1859	3.1845
036	3.5625	3.5619	3.5639	3.5625	3.5625	3.5611	3.5621	3.5607	3.5604	3.5590
040	3.9375	3.9369	3.9389	3.9375	3.9375	3.9361	3.9357	3.9371	3.9354	3.9340
044	4.3750	4.3744	4.3764	4.3750	4.3750	4.3736	4.3746	4.3732	4.3729	4.3715
048	4.7500	4.7493	4.7516	4.7500	4.7500	4.7484	4.7495	4.7418	4.7476	4.7460
052	5.1250	5.1243	5.1266	5.1250	5.1250	5.1234	5.1245	5.1230	5.1226	5.1210
056	5.5000	5.4993	5.5016	5.5000	5.5000	5.4984	5.4995	5.4980	5.4976	5.4960
060	5.8750	5.8743	5.8766	5.8750	5.8750	5.8734	5.8745	5.8730	5.8726	5.8710
064	6.2500	6.2490	6.2516	6.2500	6.2500	6.2484	6.2495	6.2480	6.2476	6.2460
068	6.6250	6.6240	6.6266	6.6250	6.6250	6.6234	6.6245	6.6230	6.6226	6.6210
072	7.0000	6.9990	7.0016	7.0000	7.0000	6.9984	6.9995	6.9980	6.9976	6.9960
076	7.3750	7.3740	7.3768	7.3750	7.3750	7.3732	7.3744	7.3726	7.3728	7.3710
080	7.7500	7.7490	7.7518	7.7500	7.7500	7.7482	7.7494	7.7476	7.7478	7.7460
096	8.7500	8.7490	8.7518	8.7500	8.7500	8.7482	8.7494	8.7476	8.7478	8.7460

DIMENSIONS IN MILLIMETERS										
BEARING SERIES GE..ES GE..ES..2RS	Ⓐ Suggested Housing Bore For Press Fit of Spherical Plain Bearings									
	Bearing Outside Diameter		ISO H7		ISO M7		ISO N7		Extra Heavy Press Fit	
	Max.	Min.	Max.	Min.	Max.	Min.	Max.	Min.	Max.	Min.
12	22.000	21.991	22.021	22.000	22.000	21.979	21.993	21.972	21.982	21.962
15	26.000	25.991	26.021	26.000	26.000	25.979	25.993	25.972	25.962	25.937
17	30.000	29.991	30.021	30.000	30.000	29.979	29.993	29.972	29.962	29.937
20	35.000	34.989	35.025	35.000	35.000	34.975	34.992	34.967	34.962	34.937
25	42.000	41.989	42.025	42.000	42.000	41.975	41.992	41.967	41.967	41.937
30	47.000	46.989	47.025	47.000	47.000	46.975	46.992	46.967	46.967	46.937
35	55.000	54.987	55.030	55.000	55.000	54.970	54.991	54.961	54.967	54.937
40	62.000	61.987	62.030	62.000	62.000	61.970	61.991	61.961	61.967	61.937
45	68.000	67.987	68.030	68.000	68.000	67.970	67.991	67.961	67.967	67.937
50	75.000	74.987	75.030	75.000	75.000	74.970	74.991	74.961	74.967	74.937
60	90.000	89.985	90.035	90.000	90.000	89.965	89.990	89.955	89.967	89.911
70	105.000	104.985	105.035	105.000	105.000	104.965	104.990	104.955	104.967	104.911
80	120.000	119.985	120.035	120.000	120.000	119.965	119.990	119.955	119.967	119.911
90	130.000	129.982	130.040	130.000	130.000	129.960	129.988	129.948	129.939	129.898
100	150.000	149.982	150.040	150.000	150.000	149.960	149.988	149.948	149.939	149.898
110	160.000	159.975	160.040	160.000	160.000	159.960	159.988	159.948	159.939	159.898
120	180.000	179.975	180.040	180.000	180.000	179.960	179.988	179.948	179.939	179.898
140	210.000	209.970	210.046	210.000	210.000	209.954	209.949	209.940	209.995	209.898
160	230.000	229.970	230.046	230.000	230.000	229.954	229.949	229.940	229.995	229.898



# SUGGESTED SHAFT SIZES

Inch Spherical Plain Bearings



DIMENSIONS IN INCHES								
Suggested Shaft Size for Spherical Plain Bearings								
Nominal Bore	ISO f6		ISO g6		ISO h6		ISO m6	
	Max.	Min.	Max.	Min.	Max.	Min.	Max.	Min.
.1900	.1896	.1893	.1898	.1895	.1900	.1897	.1904	.1902
.2500	.2495	.2491	.2498	.2495	.2500	.2496	.2506	.2502
.3125	.3120	.3116	.3123	.3119	.3125	.3121	.3131	.3127
.3750	.3745	.3741	.3748	.3744	.3750	.3746	.3756	.3752
.4375	.4369	.4364	.4373	.4368	.4375	.4371	.4382	.4378
.5000	.4994	.4989	.4998	.4993	.5000	.4996	.5007	.5003
.6250	.6244	.6239	.6248	.6243	.6250	.6246	.6257	.6253
.7500	.7492	.7487	.7497	.7492	.7500	.7495	.7508	.7503
.8750	.8742	.8737	.8747	.8742	.8750	.8745	.8758	.8753
1.0000	.9992	.9987	.9997	.9992	1.0000	.9995	1.0008	1.0003
1.2500	1.2490	1.2484	1.2496	1.2490	1.2500	1.2494	1.2510	1.2504
1.3750	1.3740	1.3734	1.3746	1.3740	1.3750	1.3744	1.3760	1.3754
1.5000	1.4990	1.4984	1.4996	1.4990	1.5000	1.4994	1.5010	1.5004
1.7500	1.7490	1.7484	1.7496	1.7490	1.7500	1.7494	1.7510	1.7504
2.0000	1.9988	1.9981	1.9996	1.9989	2.0000	1.9993	2.0012	2.0004
2.2500	2.2488	2.2481	2.2496	2.2489	2.2500	2.2493	2.2512	2.2504
2.5000	2.4988	2.4981	2.4996	2.4989	2.5000	2.4993	2.5012	2.5004
2.7500	2.7488	2.7481	2.7496	2.7489	2.7500	2.7493	2.7512	2.7504
3.0000	2.9988	2.9981	2.9996	2.9989	3.0000	2.9983	3.0012	3.0004
3.2500	3.2486	3.2477	3.2495	3.2487	3.2500	3.2491	3.2514	3.2505
3.5000	3.4986	3.4977	3.4995	3.4987	3.5000	3.4991	3.5014	3.5005
3.7500	3.7486	3.7477	3.7495	3.7487	3.7500	3.7491	3.7514	3.7505
4.0000	3.9986	3.9977	3.9995	3.9987	4.0000	3.9991	4.0014	4.0005
4.2500	4.2486	4.2477	4.2495	4.2487	4.2500	4.2491	4.2514	4.2505
4.5000	4.4986	4.4977	4.4995	4.4987	4.5000	4.4991	4.5014	4.5005
4.7500	4.7483	4.7473	4.7494	4.7485	4.7500	4.7490	4.7516	4.7506
5.0000	4.9983	4.9973	4.9994	4.9985	5.0000	4.9990	5.0016	5.0006
6.0000	5.9983	5.9973	5.9994	5.9985	6.0000	5.9990	6.0016	6.0006

**ISO f6:**

Recommended for application where movement of the shaft within the bore of the ball is expected and desired

**ISO g6:**

Recommended for applications where minor movement is expected or tolerable. Sometimes referred to as “push fit”.

**ISO h6:**

Recommended for applications where minor movement is not desired but is tolerable.

**ISO m6:**

Recommended for applications where movement between shaft and bearing bore is not desired, and an interference fit is required. Sometimes referred to as “press fit”.

**NOTE:**

Even with m6 fit, under high loads, movement may still occur between shaft and ball bore.

DIMENSIONS IN MILLIMETERS								
Suggested Shaft Size								
Nominal Bore	ISO f6		ISO g6		ISO h6		ISO m6	
	Max.	Min.	Max.	Min.	Max.	Min.	Max.	Min.
3	2.990	2.982	2.996	2.988	3.000	2.992	3.012	3.004
5	4.990	4.982	4.996	4.988	5.000	4.992	5.012	5.004
6	5.990	5.982	5.996	5.988	6.000	5.992	6.012	6.004
8	7.987	7.978	7.995	7.986	8.000	7.991	8.015	8.006
10	9.987	9.978	9.995	9.986	10.000	9.991	10.015	10.006
12	11.984	11.973	11.994	11.983	12.000	11.989	12.018	12.007
15	14.984	14.973	14.994	14.983	15.000	14.989	15.018	15.007
17	16.984	16.973	16.994	16.983	17.000	16.989	17.018	17.007
20	19.980	19.967	19.993	19.980	20.000	19.987	20.021	20.008
25	24.980	24.967	24.993	24.980	25.000	24.987	25.021	25.008
30	29.980	29.967	29.993	29.980	30.000	29.987	30.021	30.008
35	34.975	34.959	34.991	34.975	35.000	34.984	35.025	35.009
40	39.975	39.959	39.991	39.975	40.000	39.984	40.025	40.009
45	44.975	44.959	44.991	44.975	45.000	44.984	45.025	45.009
50	49.975	49.959	49.991	49.975	50.000	49.984	50.025	50.009
60	59.970	59.951	59.990	59.971	60.000	59.981	60.030	60.011
70	69.970	69.951	69.990	69.971	70.000	69.981	70.030	70.011
80	79.970	79.951	79.990	79.971	80.000	79.981	80.030	80.011
90	89.964	89.942	89.988	89.966	90.000	89.978	90.035	90.013
100	99.964	99.942	99.988	99.966	100.000	99.978	100.035	100.013
110	109.964	109.942	109.988	109.966	110.000	109.978	110.035	110.013
120	119.964	119.942	119.988	119.966	120.000	119.978	120.035	120.013
140	139.957	139.932	139.986	139.961	140.000	139.975	140.040	140.015
160	159.957	159.930	159.986	159.961	160.000	159.975	160.040	160.015

**ISO f6:**

Recommended for application where movement of the shaft within the bore of the ball is expected and desired

**ISO g6:**

Recommended for applications where minor movement is expected or tolerable. Sometimes referred to as “push fit”.

**ISO h6:**

Recommended for applications where minor movement is not desired but is tolerable.

**ISO m6:**

Recommended for applications where movement between shaft and bearing bore is not desired, and an interference fit is required. Sometimes referred to as “press fit”.

**NOTE:**

Even with m6 fit, under high loads, movement may still occur between shaft and ball bore.

**SHAFT DESIGN:**

It is generally recommended that shafts or pins be heat treated to a surface hardness of HRc 55 minimum, and have a surface finish of 32 rms or micro inches aa (arithmetic average). In applications with light loads and interference fit, a fully hardened shaft may not be necessary, but is still recommended. Under very heavy loads, an interference fit is no guarantee that there will be no movement of the shaft within the ball bore.

Figure 1

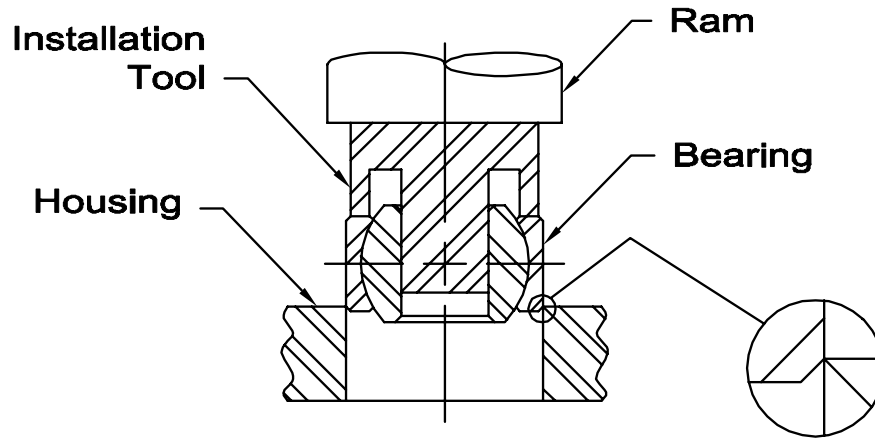

### SPHERICAL BEARING INSTALLATION

Proper installation of the bearing is important to prevent bearing failure as well as housing damage. Under no circumstances should a tool that induces shock or impact to the bearing be used. The use of an arbor press or hydraulic press is recommended. A tool as shown above (Figure 1) is advised. All force is to be applied on the bearing race face (not on ball). A lead chamfer or radius on the bearing and/or housing is vital.

### HOUSING CHAMFER - GROOVED BEARINGS

CHAMFER FOR GROOVE TYPES	
GROOVE TYPE A	.020 ± .005
GROOVE TYPE B	.030 ± .005
GROOVE TYPE C	.050 ± .005

Chamfer  
See Chart

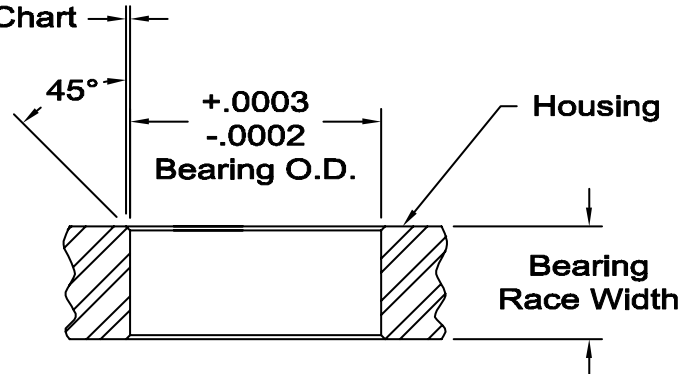

### STAKING GROOVE TYPES

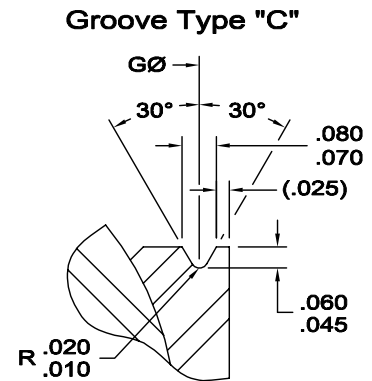
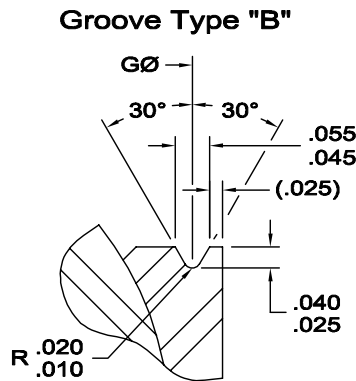
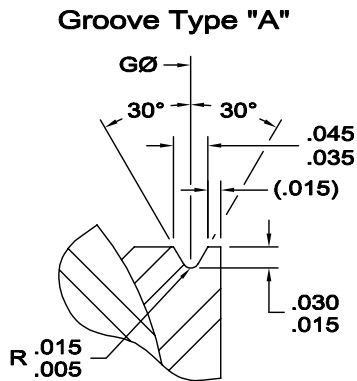

**Figure 2**

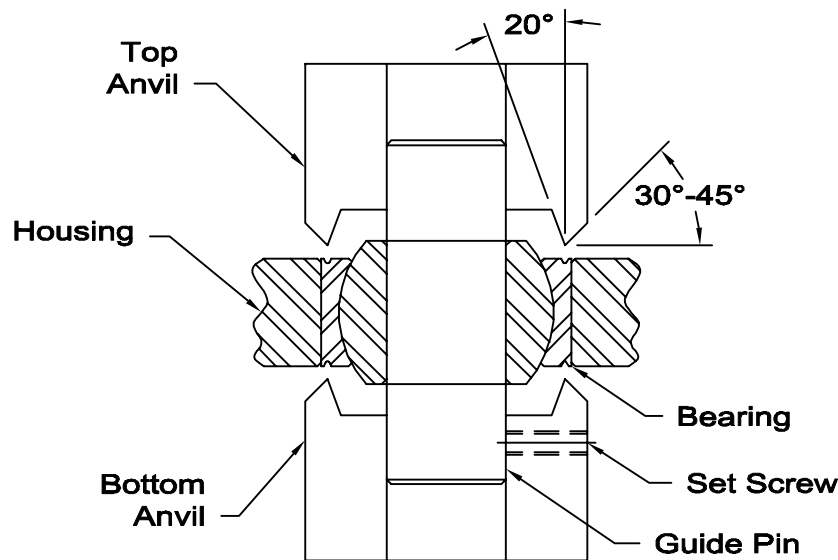

### SPHERICAL BEARING INSTALLATION

The bearings have grooves in each side of the bearing race face, leaving a small lip. Staking tools (as shown above in Figure 2) are then used to stake the lip over the chamfer edges of the housing. A typical arrangement consists of two identical anvils and one guide pin which is secured by a set screw in the bottom anvil.

### PROCEDURES

1. Install bearing into housing as shown in Figure 1 (pg. 76) and position bearing symmetrical about housing centerline.
2. Align bearing with staking tool and guide pin as shown in Figure 2.
3. A trial stake assembly should be made to determine staking force necessary to meet thrust load requirements. Proper staking force is required because excessive pressure could result in bearing distortion along with life.
4. Pressure established by trial assembly is to be applied. After first stake is completed rotate assembly 90° and re-apply. Repeat operation through a minimum of three rotations to insure 360° uniformity of stake.
5. After staking, a slight gap may exist between race lip and housing chamfer. This slight gap (shown below) may not be cause for rejection if bearing meets or exceeds thrust loads.

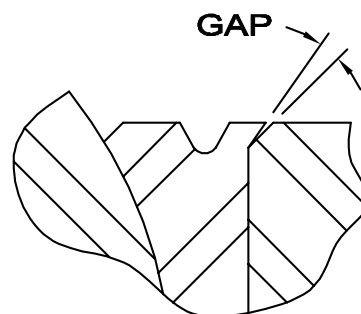

## GROOVE A

ANC-3TG  
 ANC-4TG  
 AWC-3TG  
 AWC-4TG  
 AWC-5TG  
 HAB-3TG  
 HAB-4TG  
 HAB-5TG  
 HAB-5TG-3  
 HAB-6TG  
 HAB-7TG  
 HAB-8TG  
 PNB-3TG  
 PNB-4TG  
 PWB-3TG  
 PWB-4TG  
 PWB-5TG

## GROOVE B

ANC-5TG  
 ANC-5TGA  
 ANC-6TG  
 ANC-7TG  
 AWC-6TG  
 AWC-7TG  
 AWC-7TGA  
 AWC-8TG  
 AWC-9TG  
 AWC-10TG  
 HAB-10TG  
 HAB-12TG  
 HAB-14TG  
 PNB-5TG  
 PNB-6TG  
 PNB-7TG  
 PWB-6TG  
 PWB-7TG  
 PWB-8TG  
 PWB-9TG  
 PWB-10TG

## GROOVE C

ANC-8TG  
 ANC-9TG  
 ANC-10TG  
 ANC-12TG  
 ANC-14TG  
 ANC-16TG  
 AWC-12TG  
 AWC-14TG  
 AWC-16TG  
 PNB-8TG  
 PNB-9TG  
 PNB-10TG  
 PNB-12TG  
 PWB-12TG



# PTFE LINER SPECIFICATIONS

## PTFE LINERS

PTFE (bonded coated PTFE liner) lined races are available in all three-piece bearing units and all spherical bearings. The steel race has a self-lubricating liner; a PTFE impregnated woven fabric, chemically bonded to the inner diameter of the race. Our PTFE Liners are maintenance free and offer improved frictional characteristics. Following are the liners that Timken Aurora Bearing Company offers.

Liner Designation	AT 1400	AT 2100	AT 2300	AT 3200
<b>Construction</b>	PTFE/Dacron Laminate	PTFE/Fiberglass Weave	PTFE/Dacron Weave	PTFE/Nomex Laminate
<b>Thickness (in.)</b>	.012-.014	.010-.012	.013-.015	.014-.016
<b>Temperature (°F)</b>	-65° to 250°	-65° to 250°	-65° to 250°	-65° to 325°
<b>Static Limit Load</b>	80,000 PSI	60,000 PSI	75,000 PSI	80,000 PSI
<b>Stiffness</b>	Medium to High	Medium	Low	Medium to High
<b>Typical Performance</b>	40,000 PSI @ ±25° & 10-20 cpm .0045 wear max. @ 25,000 cycles	25,000 PSI @ ±25° & 10-20 cpm .0060 wear max. @ 5,000 cycles	Contact Aurora Bearing Company Engineering Department	40,000 PSI @ ±25° & 10-20 cpm .0045 wear max. @ 100,000 cycles
<b>Dynamic Capabilities</b>	Light to medium, unidirectional or alternating loads. Low speed intermittent to continuous misalignment, intermittent to continuous oscillation.	Light unidirectional loads. Low speed, intermittent to continuous misalignment, intermittent to continuous oscillation	Light to medium, alternating or reversing loads. Medium to high speed, intermittent to continuous misalignment, intermittent to continuous oscillation.	Light to heavy, unidirectional or alternating loads. Low speed, intermittent to continuous misalignment, intermittent to continuous oscillation.
<b>Comments</b>	Good multi-purpose system	Excellent stick-slip properties, usually recommended for high splash or underwater applications	Excellent stick-slip properties, good vibratory conditions	Highest performance characteristics for all applications, Qualified to SAE-AS81820 Type A

timkenaurorabearing.com • Fax 630-859-0971

## TEMPERATURE LIMITS

The following is a listing of the ultimate temperatures Timken Aurora Bearing Company standard catalog series are capable of operating at. With the exception of the PTFE lined series, all bearings must be well lubricated with a suitable grease to meet the stated temperature.

250° F	300° F	325° F	400° F	500° F	600° F
MM-T	GE	HXAM-T	CM	AM	SM-E
MW-T	GE...ES	HAB-T	CW	AW	SW-E
AM-T	GEZ...ES	PRM-T	VCM	AM-M	COM-E
AW-T		PRXM-T	VCW	AW-M	
CM-ET		PNB-T/-TG	MM	COM-KH	
CW-ET		PWB-T/-TG	MW	HCOM-KH	
MM-MT		ASM(K)-T	KM	AIB	
MW-MT		ASW(K)-T	KW	SIB	
AIB-T		ANC-T/-TG	SM	XAM	
COM-T		AWC-T/-TG	SW	RAM	
MIB-T		AJB	CM-S	RXAM	
SIB-T		ATM(K)-T	CW-S		
KM-T		ATW(K)-T	CM-M		
KW-T		ASM(K)-ET	CW-M		
HCOM-T		ASW(K)-ET	MM-M		
COM-ET		ATM(K)-ET	MW-M		
GE...ES-2RS		ATW(K)-ET	KM-M		
GEZ...ES-2RS			KW-M		
GE...ET-2RS			COM-M		
GEZ...ET-2RS			COM		
ALM-T			HCOM		
XALM-T			MIB		
RAM-T			LCOM		
RXAM-T			XM		
SM-T			ASM(K)		
SW-T			ASW(K)		
SM-ET			GMM		
SW-ET			GMW		
			CAM		
			VCAM		
			VCAW		



# FREQUENTLY ASKED QUESTIONS

## WHAT DIRECTION IS AN AXIAL LOAD APPLIED?

The load is applied through the axis of the ball bore.

## WHAT IS THE AXIAL STATIC LOAD CAPACITY OF TIMKEN AURORA BEARING ROD ENDS?

For Aurora two-piece rod ends, the maximum axial static load capacity is recommended to be 15% of the ultimate radial static load capacity. For three-piece rod ends, the maximum axial static load capacity is recommended to be 10% of the ultimate radial static load capacity. However, on three-piece units, factors such as race material, body material, and dimensions may affect the axial static load capacity. For further information, consult the Timken Aurora Bearing engineering department.

## WHAT IS THE AXIAL STATIC LOAD CAPACITY OF TIMKEN AURORA BEARING SPHERICAL BEARINGS?

The maximum axial static load capacity on Aurora spherical bearings is recommended at 20% of the radial static load. Extreme care should be used on selecting a sufficiently strong housing to accept this type of bearing.

## WHAT DIRECTION IS A RADIAL LOAD APPLIED?

The load is applied through the axis of the shank of the male or female body.

## IS THERE A SAFETY FACTOR INCLUDED IN THE ULTIMATE RADIAL STATIC LOAD CAPACITY?

You should assume that there is no safety factor. The bearing will fail at the listed load.

## WHAT IS AXIAL PLAY (ENDPLAY)?

The measurement of the total range of movement of the ball inside the insert/body in the axial direction or the clearance measured along the axis of the ball bore.

## WHAT IS RADIAL PLAY?

The measurement of the total range of movement of the ball inside the insert/body in the radial direction or the clearance measured along the axis of the shank of the male or female body.

## WHAT MAINTENANCE DO I NEED TO PERFORM ON MY ROD ENDS AND SPHERICAL BEARINGS TO KEEP THEM OPERATING PROPERLY?

For metal-to-metal rod ends and spherical bearings, a thin layer of grease applied occasionally to ball outside diameter will assist in extending the life of these products. Rod ends and spherical bearings that are PTFE lined are self-lubricating and are designed to be maintenance free and should not be lubricated.

## WHAT IS THE MINIMUM THREAD ENGAGEMENT REQUIRED TO SUPPORT THE LISTED LOAD RATINGS IN THE TIMKEN AURORA BEARING COMPANY CATALOG?

The minimum thread engagement is 1.5 times the major thread diameter unless otherwise stated.

## WHAT IS THE THICKNESS OF THE PTFE LINER?

The thickness of the "AT" series PTFE liner is between .012"-.016" thick depending on which liner is chosen. (see page 118)

## WHAT IS THE MAXIMUM RPM THAT A ROD END OR SPHERICAL BEARING CAN OPERATE AT?

When a rod end or spherical bearing is to be applied in full rotation, the surface speed of the ball should be kept below 20 feet per minute or the rotational speed should be below 100 RPM, whichever is lower, with the operating loads not to exceed 10% of the ultimate radial static load capacity.

## WHAT IS THE OPERATING TEMPERATURE OF PTFE LINED BEARINGS?

Commercial grade liner = -65°F to +250°F  
AS8120, Type A liner = -65°F to +325°F  
(see pages 118 – 119)

## HOW MUCH CORROSION RESISTANCE DO ZINC PLATED ROD ENDS PROVIDE?

All zinc plated rod ends are plated to meet or exceed the requirements of ASTM B 633.

## DOES TIMKEN AURORA BEARING COMPANY OFFER 2D AND 3D DRAWINGS OF THEIR BEARINGS?

Yes, they can be found under the "CAD Drawings" at [cad.timken.com](http://cad.timken.com). See page 125 for further information

## DOES TIMKEN AURORA BEARING COMPANY OFFER CUSTOM OR MADE TO ORDER BEARINGS?

Yes, Timken Aurora Bearing has the ability to manufacture many types of specialty bearings not listed in the catalog.



# REFERENCE

## Inch / Metric Conversion Table



Most commonly used conversions in **Bold**.

INCH		MM	INCH		MM	INCH		MM	INCH		MM
FRACT.	DEC.		FRACT.	DEC.		FRACT.	DEC.		FRACT.	DEC.	
	0.00004	0.001	17/64	0.2656	6.746		0.6693	17.0		1.3780	35.0
	0.00039	0.01		0.2756	7.0	43/64	0.6719	17.066		1.4173	36.0
	0.0010	0.025	9/32	0.2812	7.1437	11/16	0.6875	17.4625	1 1/2	1.5000	38.1
	0.0020	0.051	19/64	0.2969	7.5406	45/64	0.7031	17.859		1.5354	39.0
	0.0030	0.0762	<b>5/16</b>	<b>0.3125</b>	<b>7.9375</b>		0.7086	18.0		1.5748	40.0
	0.00394	0.1		0.3150	8.0	23/32	0.7187	18.256		1.6535	42.0
	0.0050	0.1270	21/64	0.3281	8.334	47/64	0.7334	18.653	1 3/4	1.7500	44.45
	0.00984	0.25	11/32	0.3437	8.731		0.7480	19.0		1.7717	45.0
	0.0100	0.254		0.3543	9.0	<b>3/4</b>	<b>0.7500</b>	<b>19.05</b>		1.8898	48.0
1/64	0.0156	0.396	23/64	0.3594	9.1281	49/64	0.7656	19.446		1.9685	50.0
1/32	0.0312	0.793	<b>3/8</b>	<b>0.3750</b>	<b>9.525</b>	25/32	0.7812	19.843	2	2.0000	50.8
	0.03937	1.0	25/64	0.3906	9.9219		0.7874	20.0		2.0472	52.0
3/64	0.0469	1.191		0.3937	10.0	51/64	0.7969	20.240		2.1654	55.0
	0.0591	1.5	13/32	0.4062	10.318	13/16	0.8125	20.6375		2.2047	56.0
1/16	0.0625	1.5875	27/64	0.4219	10.716		0.8268	21.0	2 1/4	2.2500	57.15
5/64	0.0781	1.984		0.4331	11.0	53/64	0.8281	21.034		2.3622	60.0
	0.0787	2.0	<b>7/16</b>	<b>0.4375</b>	<b>11.1125</b>	27/32	0.8437	21.431	2 1/2	2.5000	63.5
3/32	0.0937	2.381	29/64	0.4531	11.509	55/64	0.8594	21.828		2.5197	64.0
	0.0984	2.5	15/32	0.4687	11.906		0.8661	22.0	2 3/4	2.7500	69.85
	0.1000	2.54		0.4724	12.0	<b>7/8</b>	<b>0.8750</b>	<b>22.225</b>		2.8346	72.0
7/64	0.1094	2.778	31/64	0.4844	12.303	57/64	0.8906	22.621		2.9528	75.0
	0.1181	3.0	<b>1/2</b>	<b>0.5000</b>	<b>12.7</b>		0.9055	23.0	3	3.0000	76.2
1/8	0.1250	3.175		0.5118	13.0	29/32	0.9062	23.018		3.1496	80.0
	0.1387	3.5	33/64	0.5156	13.096	59/64	0.9219	23.416	3 1/4	3.2500	82.55
9/64	0.1406	3.571	17/32	0.5312	13.493	15/16	0.9375	23.8125	3 1/2	3.5000	88.9
5/32	0.1562	3.968	35/64	0.5469	13.891		0.9449	24.0		3.5433	90.0
	0.1575	4.0		0.5512	14.0	61/64	0.9531	24.209	3 3/4	3.7500	95.25
11/64	0.1719	4.366	<b>9/16</b>	<b>0.5625</b>	<b>14.2875</b>	31/32	0.9687	24.606		3.9370	100.0
	0.1772	4.5	37/64	0.5781	14.684		0.9843	25.0	4	4.0000	101.6
<b>3/16</b>	<b>0.1875</b>	<b>4.7625</b>		0.5906	15.0	63/64	0.9844	25.003	4 1/4	4.2500	107.95
	0.1969	5.0	19/32	0.5937	15.081	1	1.0000	25.4		4.3307	110.0
13/64	0.2031	5.159	39/64	0.6094	15.478		1.0630	27.0	4 1/2	4.5000	114.3
7/32	0.2187	5.556	<b>5/8</b>	<b>0.6250</b>	<b>15.875</b>		1.1024	28.0		4.7244	120.0
15/64	0.2344	5.953		0.6299	16.0		1.1811	30.0	4 3/4	4.7500	120.65
	0.2362	6.0	41/64	0.6406	16.271	1 1/4	1.2500	31.75	5	5.0000	127.0
<b>1/4</b>	<b>0.2500</b>	<b>6.35</b>	21/32	0.6562	16.668		1.2992	33.0	5 1/2	5.5000	139.7

timkenaurorabearing.com • Fax 630-859-0971

## INCH/METRIC CONVERSION FACTORS

Inches	x 25.4	= Millimeters	Pounds	x .4536	= Kilograms	Pounds(Force)x 4.448	= Newtons	
Millimeters	x .03937	= Inches	Kilograms	x 2.2046	= Pounds	Newtons	x .2248	= Pounds(Force)
Sq. Inches	x 6.4515	= Sq. Centimeters	Lbs. per In. <sup>2</sup>	x .0703	= kg per cm <sup>2</sup>	Temperature Conversion (Approximate)		
Sq. Centimeters	x .155	= Sq. Inches	kg per cm <sup>2</sup>	x 14.2231	= Lbs. per In. <sup>2</sup>	Degrees C = (Degrees F - 32) (.5556)		
						Degrees F = (Degrees C) (1.8) + 32		

TAP DRILL SIZES FOR INCH THREADS			
Screw Thread		Commercial Tap Drills	
Thread size	Root Dia.	Size or Number	Decimal Equiv.
6-32	0.0834	36	0.1065
10-32	0.1469	22	0.1570
1/4-28	0.2036	3	0.2130
5/16-24	0.2584	I	0.2720
3/8-24	0.3209	Q	0.3320
7/16-20	0.3726	25/64	0.3906
1/2-13	0.4001	27/64	0.4219
1/2-20	0.4351	29/64	0.4531
5/8-11	0.5069	17/32	0.5312
5/8-18	0.5528	37/64	0.5781
3/4-16	0.6688	11/16	0.6875
7/8-14	0.7822	13/16	0.8125
1-12	0.8918	59/64	0.9219
1-14	0.9072	15/16	0.9375
1 1/4-12	1.1418	1 11/64	1.1719
1 1/2-12	1.3918	1 27/64	1.4219
1 3/4-12	1.6050	1 21/32	1.6563
2-12	1.8557	1 29/32	1.9063

TAP DRILL SIZE METRIC THREADS	
THREAD SIZE/TAP	METRIC DRILL SIZE
M3 X 0.5	2.50
M5 X 0.8	4.20
M6 X 1.0	5.00
M8 X 1.0	7.00
M8 X 1.25	6.80
M10 X 1.25	8.80
M10 X 1.5	8.50
M12 X 1.25	10.80
M12 X 1.75	10.20
M14 X 1.5	12.50
M14 X 2.0	12.00
M16 X 1.5	14.50
M16 X 2.0	14.00
M18 X 1.5	16.50
M20 X 1.5	18.50
M20 X 2.5	17.50
M22 X 1.5	20.50
M24 X 2.0	22.00
M30 X 2.0	28.0

These tables above are to be used as a guides only. Consult the appropriate reference to determine best size based on fit requirements, materials used, etc.

### ALUMINUM DESIGNATION CROSS REFERENCE TABLE

USA	BRITAIN	EU	CHINA	GERMANY	ITALY	JAPAN
AA	B.S.	DIN 17007	GB	DIN 1700	UNI	JIS
2014	H15	3.1255	LD20	AlCuSiMn	"P-AlCu4,4SiMnMg"	A2014
2024	2L97/98	3.1355	LY12	AlCuMg2	"P-AlCu4,5MgMn"	A2024
6061	H20	3.3211	LD30	AlMg1SiCu	P-AlMg1SiCu	A6061
7075	2L95/96	3.4365	LC9	AlZnMgCu1.5	"P-AlZn5,8MgCu"	A7075

### STEEL DESIGNATION CROSS REFERENCE TABLE

USA	BRITAIN	EU	CHINA	GERMANY	ITALY	JAPAN
AISI	B.S. 970	EN	GB	DIN	UNI	JIS
1015	040A15	32C	15	Ck15	C15	S15C
1018	080A15	32B	20Mn	C16.8	1C15	S18C
1022	120M19			20Mn5	G22Mn3	S20C
1045	080A47	43B	45	C45	C45	S45C
1144	212M44		Y40Mn	45S20	CF44SMn28	SUM43
1215	230M07	1B	Y13	9SMn36		SUM23
4130	708A30		25CrMo4	25CrMo4	25CrMo4	SCM420
4140	708M40	19	42CrMo	41CrMo4	41CrMo4	SCM440
4340	817M40	24	40CrNiMoA	34CrNiMo6	35NiCrMo6 KB	SNM447
52100	534A99	31	GCr15	100Cr6	100Cr6	SUJ2
303	303S21	X8CrNiS18-9	Y1Cr18Ni9	X10CrNiS18-9	X10CrNiS 18 09	SUS303
410	410S21	56A	1Cr13	X15Cr13		SUS410
440C	A-1b	9Cr18	X105CrMo17		SUS440C	
17-4				X5CrNiCuNb1714		SUS80

These tables are to be used as a guides to assist in finding comparable metal designations only. True interchange can be determined only by comparing chemical composition, mechanical properties, and manufacturing technologies.

# TERMS TRANSLATIONS



A guide to translate common rod end industry terms from English to noted language. **This is a guide only.** Consultation with appropriate language references is recommended for best accuracy.



	English	French	German	Italian	Portugese	Spanish
	Aerospace	Aérospatial	Luftfahrt	Aerospaziale	Aeroespacial	Aeroespacial
	Aluminum	Aluminium	Aluminium	Alluminio	Aluminio	Aluminio
	Axial	Axiale	Axial	Assiali	Axial	Axial
	Ball	Bague interieure	Innenringe	Anello Interno	anel intero	Esfera
	Body	Corps	Gehaeuse	Testa	Corpo	cuerpo
A	Base to Center	base pour centrer longueur	Abstand, Unterseite zur Mitte	lunghezza, da base al centro	distância, base ao centro	altura, base a centro
B	Bore	Alesages	Bohrung	foro	Furo	agujero
	Commercial		Kommerziell	uso generico	Comercial	Comercial
	Chrome plate	chromage	verchromt	cromatura	Placa do cromo	cromado
D	Diameter	Diametre	Durchmesser	Diametro	Diametro	Diametro
	Female thread	Filetages Femelle	Innengewinde	Filettatura intera	Rosca Femea	rosca hembra
	Grease Fitting	Graisseur	Schmiernippel	Ingrassatore	lubrificador	lubricador
H	Head or Race Width	largeur de logement	Gehaeusebreite / Lagerschalenbreite	spessore testa / spessore boccola	largura externa do anel	anchura de la pista
	Industrial grade	Industriel	Industrie-Qualitaet	qualità industriale		Industrial
	Keyway	Rainure de Clavette	Keilnute	Scanalatura		cunero
	Left Hand	gauche	Links	sinistra	inversa	Rosca izquierda
	Load capacity	capacite de charges	belastbar	capacità di carico	Capacidade da carga	Capacidad de Carga
	Male thread	Filetages male	Aussengewinde	maschio filettato	Rosca macho	Rosca macho
	Military Specification	Spécifications Militaires	Militär-Vorschrift	Specifica Militare	Especificação Militar	Especificacion Militar
á	Misalignment	angulaires	Kippwinkel	ribaltamento	inclinacao	desalineamiento
	Race	Logement	Lagerschale	boccola / anello esterno	anel externo	Pista
	Radial	Radiale	Radial	Radiali	Radial	Radial
	Right Hand	Normes, Droite	Rechts	a destra	normal	Rosca Derecha
	Radial Static Load Capacity	charge statique	statische Tragzahl	Carico Statico	Capacidades de carga estatica	Carga radial maxima
	Rod end	Embouts	Gelenkkopf, pl. Gelenkkoepfe	Teste a Snodo	Terminais Rotulares	Cabezas de articulación
	Spherical bearing	Rotules	Gelenklager	Snodi Sferici	Rotulas	Rotula Esferica
	Stainless steel	Acier Inoxydable	Rostfrei	Acciaio inox	Aco inox	Acero inoxidable
	Steel	Acier	Stahl	Acciaio	Aco	Acero
	Thread	Filetage	Gewinde	Filettatura	Rosca	Rosca
C	Thread Length	longueur du filetage	Gewindelaenge	lunghezza del filetto	comprimento da rosca	Longitud de Rosca
W	Width of ball	largeur bille	Innenringbreite	spessore anello interno	largura interna do anel	anchura de la esfera

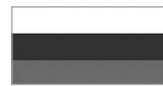

	English	Chinese	Japanese	Korean	Russian
	Aerospace	航天	航空宇宙	항공우주	авиакосмический
	Aluminum	铝	アルミ	알루미늄	алюминий
	Axial	轴向	軸方向の	축 방향	осевой
	Ball	内圈	玉, 内輪	볼	шар
	Body	体	体	바디	тело
A	Base to Center	从底部的长度到中心	下から中心部までの長さ	중심부터 바닥거리	Расстояние от базы до центра
B	Bore	缸径	ボア	보어(실린더 지름)	внутренний диаметр
	Commercial	商业的	商業の	상품화	коммерческого класса
	Chrome plate	镀铬板	クロームプレート	크롬 플레이트	хромированная пластина
D	Diameter	轴承公称外径	径	직경	Диаметр
	Female thread	内螺纹	雌ねじ	암나사	внутренняя резьба
	Grease Fitting	润滑嘴	グリースニッ플	그리스 니플	пресс-маслёнка
H	Head or Race Width	住房的宽度	ハウジングの幅	하우징의 폭	ширина беговой дорожки
	Industrial grade	产业素质	工業用グレード	공업용	промышленного класса
	Keyway	键槽	キー溝	키 홈	шпоночный паз
	Left Hand	左手螺纹	左ねじ	좌측 방향	левая резьба
	Load capacity	静载荷额定	負荷容量	부하 용량	Грузоподъемность
	Male thread	外螺纹	雄ねじ	수나사	наружная резьба
	Military Specification	军事规格	ミリタリー仕様	국방규격	Военная спецификация
â	Misalignment	对齐角度	ミスアライメント	가용정렬각도	несоосность
	Race	种族	レース	레이스	беговая дорожка
	Radial	径向	ラジアル	원심방향	радиальный
	Right Hand	右旋螺纹	右ねじ	우측 방향	Правая резьба
	Radial Static Load Capacity	径向静负荷能力	ラジアル負荷容量	원심방향 부하 용량	Допустимая статическая нагрузка
	Rod end	杆端	ロッドエンド	로드 엔드	наконечник
	Spherical bearing	关节轴承	球面軸受	구면 베어링	Сферические подшипники скольжения
	Stainless steel	不锈钢	ステンレス鋼	스테인리스강	нержавеющая сталь
	Steel	钢	鋼	강철	сталь
	Thread	螺纹	ねじ山	나사	резьба
C	Thread Length	螺纹长度	ねじ長さ	나사 길이	Длина резьбы
W	Width of ball	球的宽度	内輪幅	공의 폭	сборочная ширина

	English	Arabic	Hindi
	Aerospace	الصناعة الجوية	एयरोस्पेस
	Aluminum	الومنيوم	अल्युमीनियम
	Axial	الاتجاه المحوري	अक्षीय
	Ball	الكرة المفصليّة المتحركة	बॉल
	Body	الجسم الخارجي للجزء	काया
A	Base to Center	النقطة المركزيّة	केंद्र के लिए आधार से दूरी
B	Bore	قطر تجويف الاسطوانة	छेद
	Commercial	للاغراض التجارية	व्यावसायिक
	Chrome plate	مطلي بالكروم	करोम प्लेट
D	Diameter	القطر	व्यास
	Female thread	سن مخروطية داخلي	महलिा धागा
	Grease Fitting	ترتيبة تشحيم	तेल नपिल
H	Head or Race Width	العرض	आवास की चौड़ाई
	Industrial grade	جودة صناعة	औद्योगिक श्रेणी
	Keyway	مجرى الخابور	कुंजी स्लॉट
	Left Hand	شمالي	बायां हाथ
	Load capacity	قوة التحمل	लोड क्षमता
	Male thread	سن مخروطية خارجي	पुरुष धागा
	Military Specification	المواصفات العسكريّة	सैन्य वनिर्दिशै
	Misalignment	اختلاف المحاذاة	संरेखण कोण
	Race	لاغراض السباق	दौड़
	Radial	محوري	रेडयिल
	Right Hand	يمني	दायां हाथ
	Radial Static Load Capacity	حمل الضغط المحوري	रेडयिल स्थरि भार क्षमता
	Rod end	طرف عمود	रॉड समाप्त होता है
	Spherical bearing	بليّة كاتينّة - حوامل كرات بلي	गोलाकार असर
	Stainless steel	فولاذ مقاوم للصدأ	स्टेनलेस स्टील
	Steel	فولاذ	स्टील
	Thread	سن مخروطية	धागा
C	Thread Length	طول سن مخروطية	धागा लंबाई
W	Width of ball	عرض البليّة الكروية	गेंद की चौड़ाई

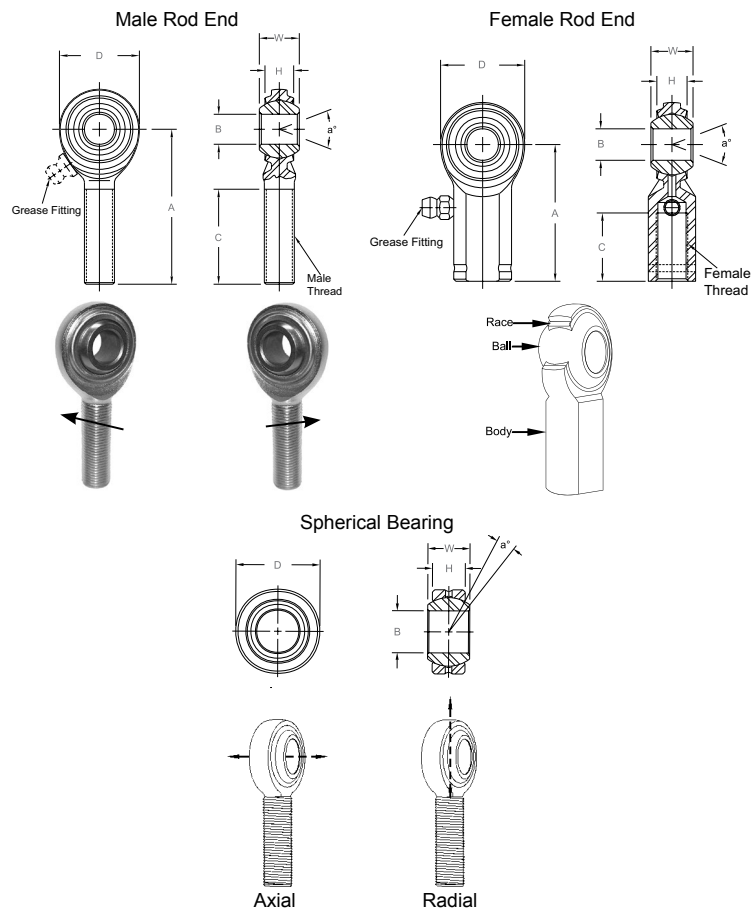

**EXCLUSIVE:  
2D AND 3D CAD DRAWINGS OF AURORA BEARING  
ROD END AND SPHERICAL BEARINGS**

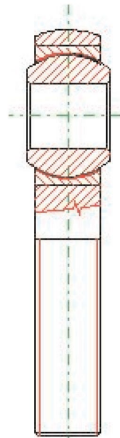

Cross section, MM-8T



3D model, MM-8T

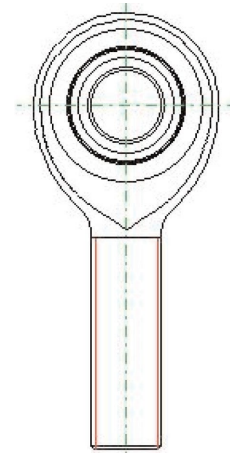

Front view, MM-8T

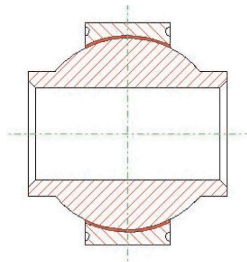

Cross section, HAB-6TG



3D model. HAB-6TG

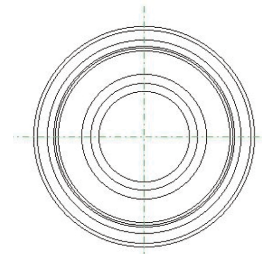

Front View, HAB-6TG

Timken Aurora Bearing has developed a CAD drawing library of its entire catalog offering of Rod End and Spherical Bearings, including Mil Spec approved parts. These 2D and 3D images are importable into most major CAD and solid modeling packages, and includes both line drawings and 3D models.

Files are accessible at [cad.timken.com](http://cad.timken.com).

Try us online... where we're more than a website, we're a resource!

The Timken Aurora Bearing website is more than just an Internet location for the Timken Aurora Bearing product catalog. It allows immediate access to:

- exclusive Timken Aurora Bearing CAD drawing library
- technical resources such as industry terms and definitions
- answers to frequently asked technical questions
- reprints of articles regarding rod ends and spherical bearings
- in-depth technical data
- interchange guides for parts used in specialized industries

**AEROSPACE – MILITARY – MOTORSPORTS – MARINE  
TRANSPORTATION – ATTRACTIONS – PACKAGING**



# AURORA

**Timken Aurora Bearing Company | 901 Aucutt Road | Montgomery, IL 60538 U.S.A.**

**PHONE: (630) 859-2030**

**FAX: (630) 859-0971**

**[timkenaurorabearing.com](http://timkenaurorabearing.com)**

**[customerservice@aurorabearing.com](mailto:customerservice@aurorabearing.com)**

The Timken team applies their know-how to improve the reliability and performance of machinery in diverse markets worldwide. The company designs, makes and markets bearings, gear drives, automated lubrication systems, belts, brakes, clutches, chain, couplings, linear motion products and related power transmission rebuild and repair services.

© 2024 The Timken Company